



**NO TIRE WORKS WITHOUT THE WHEEL
— THEY ARE A TOTAL SYSTEM**

Titan is the only company with the ability to design, test and produce both wheels and tires for mining, agriculture, construction and forestry markets.

1.800.872-2327

VOLUME 8

OTR TIRES



TITAN MOVES THE WORLD®



TITAN INTERNATIONAL, INC.

OTR DATABOOK VOLUME 8



Titan Customer Care

PHONE: 1.800.USA-BEAR

FAX: 515.265.9301

E-MAIL: sales@titan-intl.com

WEB: www.titan-intl.com



LSWadvantage.com



Contents

Radial OTR

Radial OTR

Titan 007 MFT.....	3
Titan TG2 (G-2).....	4
Titan TGS2 (G-2) or (G2/L-2)	5
Titan TGL2 (G-2/L-2)	5
Titan TGD2 (E-2/L-2)	5
Titan STL3 (E-3/L-3) Dual Purpose Tire	6
Titan MXL (E-3/L-3).....	7
Titan STL2+ (E-3T/L-3T) Dual Purpose Tire.....	7
Titan DTH4 (E-4) Haul Truck Tire.....	8
Titan DTE4 (E-4) Haul Truck Tire.....	8
Titan LDR250 (L-5).....	9
Titan LDR150 (L-4)	9

Earthmoving

Earthmoving

Titan LCM (E-3) or (E-3/L-3).....	10
Titan ND LCM (E-3) or (E-3/L-3)	10
Titan ND MCS (E-3/L-3).....	10
Titan SL 100 (E-3) or (E-3/L-3).....	11
Titan MXL (E-3/L-3).....	12
Titan Super Rigger (E-3/L-3)	12
Titan CM100 (E-3)	12
Titan XG-3 (E-3).....	13
Titan Super LCM (E-4).....	13
Titan ND Super LCM (E-4) or (E-4/L-4)	13
Titan CM 150 (E-4)	14
Titan Quarry Special CM 150 (E-4) or (E-4/L-4).....	14
Titan CH 150 (E-4/L-4)	15
Titan Super Sand Flotation (E-7).....	15

Loader - Dozer

Grader

Titan Loader Grader III (G-2) or (L-2/G-2)	16
Titan Motor Grader HD(L-2/G-2).....	16
Titan Super Grader (G-2/L-2).....	17
Titan HD 2000II (G-2).....	17

Container Handling

Loader - Dozer

Titan Loader Dozer II (L-2)	18
Titan Lift Rigger II (L-2).....	18
Titan Loader Grader III (L-2/G-2)	19
Titan Motor Grader HD (L-2/G-2)	19
Titan Super Grader (L-2/G-2).....	19
Titan Super Rigger (L-3/E-3)	20
Titan ND LCM (L-3) (L-3/E-3).....	20
Titan MCS LCM (L-3/E-3).....	20
Titan LD 100 (L-3)	21
Titan SL 100 (L-3/E-3).....	21
Titan MXL (L-3/E-3).....	21
Titan Super LCM (L-4)	22
Titan LD 150 (L-4)	22
Titan CH 150 (L-4/E-4)	22
Titan CM 150 (L-4).....	23
Titan LS 150 (L-4T).....	23
Titan LD 250 (L-5) CRB.....	23
Titan LD 250 Belted (L-5) 7x7	23
Titan LD 250 Haf-Trac (L-5/L-5S) CRB	24
Titan LD 250 Haf-Trac Belted (L-5/L-5S) 7x7.....	24
Titan LD 250 Super Smooth (L-5S) CRB	24
Titan LD 250 Super Smooth (L-5S) CAB	24
Titan LD 250 Super Smooth Belted (L-5S) 7x7	24

Underground Mining Material Handling

Underground Mining/ Material Handling

Titan LD 250 Super Smooth UGM (L-5S)	28
Titan Industrial Deep Traction	28
Titan T44	29
Titan TT472	29
Titan T40	29
Titan PWT	30
Titan Super LCM (L-4)	30

Forestry

Goodyear Logger Lug III (LS-2).....	31
Goodyear Logger Lug III HD (LS-2).....	31
Goodyear Logger Lug III Flotation (HF-4)	32

Backhoe

Goodyear IT510 (R-4) Radial	33
Goodyear IT520 (R-4) Radial.....	33
Goodyear IT525 (R-4) Radial.....	33
Goodyear IT530 (R-4) Radial.....	33
Goodyear IT515 HS (R-4)	34
Goodyear IT525 (R-4)	34
Goodyear Sure Grip Lug (R-4).....	34
Goodyear Industrial Sure Grip (R-4)	34
Titan Industrial Tractor Lug (R-4).....	35
Titan Industrial Contractor (R-4)	35
Titan Industrial Tractor Lug II (R-4)	35
Titan LSW Industrial Tractor Lug II (R-4)	35
Goodyear Laborer (F-3).....	36
Goodyear Multi Rib (F-3).....	36
Titan Contractor (F-3)	36
Titan Industrial Front Tractor (F-3)	36
Goodyear Traction Implement (I-3)	37
Goodyear Sure Grip Traction (I-3)	37
Goodyear Sure Grip Lug (I-3)	37
Goodyear Contractor (I-3).....	37
Titan Contractor (I-3).....	38
Titan Contractor II (I-3)	38
Titan TI422 (I-3).....	38
Titan Traction Implement (I-3).....	38
Goodyear IT323.....	39
Goodyear Sure Grip Lug	39
Goodyear Industrial Xtra Grip SS	39

Skid Steer

Titan Contractor FWD	40
Titan Trac Loader SS	40
Titan Trac Loader Chevron SS	40
Titan HD2000 SS	40
Titan HD2000 II SS.....	40
Titan Soft Turf	40
Titan Ultimate.....	42
Titan H/E	42
Titan Grizz LSWG9A.....	43

Smooth

Goodyear Smooth Industrial.....	44
Goodyear Compactor	44
Titan Road Roller/Road Roller II.....	44

Container Handling

Titan LCM (L-3)	25
Titan ND LCM (L-3)	25
Titan ND Super LCM (L-4/E-4).....	26
Titan CH 150 (L-4) or (L-4/E-4)	26
Titan CM 150 (L-4).....	26
Titan Super Smooth (L-4S)	27
Titan Super Smooth (L-5S)	27

Load & Inflation Tables	45
Industrial Loads	115
Paver Loads	116
Logger Lug/Flotation Loads	118
Material Handling Loads	121
Approved Rim Contours	122
Safety	5:1 (124)

Load & Inflation Tables

Safety Section



No Sipes



Sipes

Titan 007 MFT

- Large contact area provides damage resistance
- Self cleaning grooves provide excellent traction
- Tie-bars provide lug stabilization, resulting in even tread wear
- Custom compounds available
- No sipes available on some designs

ULTRA CLASS RADIAL

Tire Size	Compound/ Construction	Catalog Number	Sipes/ No Sipes	Industry Code	Load/ Speed Index	Load Rating	Rim Width Code	Flange Height Code	Outside Diameter in (mm)	Section Width in (mm)	Tread Depth in (mm)	Load @ Inflation lbs @ PSI (kg @ bar)	TMPh (TKPH)
59/80R63	HV	MHV278	Sipes	E-3	268 B	2 *	44.00	5.0	158.5 (4026)	57.4 (1461)	89/32 (71)	220,500 @ 110 (100,000 @ 7.5)	1355 (1978)
59/80R63	WV	MWV278	Sipes	E-3	268 B	2 *	44.00	5.0	158.5 (4026)	57.4 (1461)	89/32 (71)	220,500 @ 110 (100,000 @ 7.5)	1084 (1582)
59/80R63	CV	MFV278	Sipes	E-3	268 B	2 *	44.00	5.0	158.5 (4026)	57.4 (1461)	89/32 (71)	220,500 @ 110 (100,000 @ 7.5)	813 (1187)
59/80R63	SV	MSV278	Sipes	E-3	268 B	2 *	44.00	5.0	158.5 (4026)	57.4 (1461)	89/32 (71)	220,500 @ 110 (100,000 @ 7.5)	---
59/80R63	H2	MH2278	No Sipes	E-3	268 B	2 *	44.00	5.0	158.5 (4026)	57.4 (1461)	89/32 (71)	220,500 @ 110 (100,000 @ 7.5)	1287 (1879)
59/80R63	W2	MW2278	No Sipes	E-3	268 B	2 *	44.00	5.0	158.5 (4026)	57.4 (1461)	89/32 (71)	220,500 @ 110 (100,000 @ 7.5)	1030 (1503)
59/80R63	C2	MF2278	No Sipes	E-3	268 B	2 *	44.00	5.0	158.5 (4026)	57.4 (1461)	89/32 (71)	220,500 @ 110 (100,000 @ 7.5)	772 (1127)
59/80R63	S2	MS2278	No Sipes	E-3	268 B	2 *	44.00	5.0	158.5 (4026)	57.4 (1461)	89/32 (71)	220,500 @ 110 (100,000 @ 7.5)	---
59/80R63	HD	MHD278	Sipes	E-4	268 B	2 *	44.00	5.0	158.5 (4026)	57.4 (1461)	146/32 (116)	220,500 @ 110 (100,000 @ 7.5)	1016 (1483)
59/80R63	WD	MWD278	Sipes	E-4	268 B	2 *	44.00	5.0	158.5 (4026)	57.4 (1461)	146/32 (116)	220,500 @ 110 (100,000 @ 7.5)	813 (1186)
59/80R63	CD	MFD278	Sipes	E-4	268 B	2 *	44.00	5.0	158.5 (4026)	57.4 (1461)	146/32 (116)	220,500 @ 110 (100,000 @ 7.5)	610 (890)
59/80R63	H5	MH5278	No Sipes	E-4	268 B	2 *	44.00	5.0	158.5 (4026)	57.4 (1461)	146/32 (116)	220,500 @ 110 (100,000 @ 7.5)	965 (1409)
59/80R63	W5	MW5278	No Sipes	E-4	268 B	2 *	44.00	5.0	158.5 (4026)	57.4 (1461)	146/32 (116)	220,500 @ 110 (100,000 @ 7.5)	772 (1127)
59/80R63	C5	MF5278	No Sipes	E-4	268 B	2 *	44.00	5.0	158.5 (4026)	57.4 (1461)	146/32 (116)	220,500 @ 110 (100,000 @ 7.5)	579 (845)
53/80R63	HV	MHV23M	Sipes	E-4	261 B	2 *	36.00, 38.00	5.0	148.8 (3780)	53.0 (1346)	130/32 (103)	182,000 @ 110 (82,500 @ 7.5)	1001 (1461)
53/80R63	WV	MWV23M	Sipes	E-4	261 B	2 *	36.00, 38.00	5.0	148.8 (3780)	53.0 (1346)	130/32 (103)	182,000 @ 110 (82,500 @ 7.5)	801 (1169)
53/80R63	CV	MFV23M	Sipes	E-4	261 B	2 *	36.00, 38.00	5.0	148.8 (3780)	53.0 (1346)	130/32 (103)	182,000 @ 110 (82,500 @ 7.5)	601 (877)
53/80R63	H2	MH223M	No Sipes	E-4	261 B	2 *	36.00, 38.00	5.0	148.8 (3780)	53.0 (1346)	130/32 (103)	182,000 @ 110 (82,500 @ 7.5)	951 (1388)
53/80R63	W2	MW223M	No Sipes	E-4	261 B	2 *	36.00, 38.00	5.0	148.8 (3780)	53.0 (1346)	130/32 (103)	182,000 @ 110 (82,500 @ 7.5)	761 (1110)
53/80R63	C2	MF223M	No Sipes	E-4	261 B	2 *	36.00, 38.00	5.0	148.8 (3780)	53.0 (1346)	130/32 (103)	182,000 @ 110 (82,500 @ 7.5)	571 (833)
53/80R63	HG	MHG23M	Sipes	E-4	261 B	2 *	36.00, 38.00	5.0	148.8 (3780)	53.0 (1346)	130/32 (103)	182,000 @ 110 (82,500 @ 7.5)	TBD
53/80R63	WG	MWG23M	Sipes	E-4	261 B	2 *	36.00, 38.00	5.0	148.8 (3780)	53.0 (1346)	130/32 (103)	182,000 @ 110 (82,500 @ 7.5)	TBD
53/80R63	FG	MGF23M	Sipes	E-4	261 B	2 *	36.00, 38.00	5.0	148.8 (3780)	53.0 (1346)	130/32 (103)	182,000 @ 110 (82,500 @ 7.5)	TBD
53/80R63	H7	MH723M	No Sipes	E-4	261 B	2 *	36.00, 38.00	5.0	148.8 (3780)	53.0 (1346)	130/32 (103)	182,000 @ 110 (82,500 @ 7.5)	TBD
53/80R63	W7	MW723M	No Sipes	E-4	261 B	2 *	36.00, 38.00	5.0	148.8 (3780)	53.0 (1346)	130/32 (103)	182,000 @ 110 (82,500 @ 7.5)	TBD
53/80R63	C7	MF723M	No Sipes	E-4	261 B	2 *	36.00, 38.00	5.0	148.8 (3780)	53.0 (1346)	130/32 (103)	182,000 @ 110 (82,500 @ 7.5)	TBD
50/80R57	HR	MHR270	Sipes	E-4	257 B	2 *	34.00	5.0	141.5 (3594)	47.0 (1194)	105/32 (83)	161,000 @ 110 (73,000 @ 7.5)	763 (1115)
50/80R57	WR	MWR270	Sipes	E-4	257 B	2 *	34.00	5.0	141.5 (3594)	47.0 (1194)	105/32 (83)	161,000 @ 110 (73,000 @ 7.5)	611 (892)
50/80R57	CR	MFR270	Sipes	E-4	257 B	2 *	34.00	5.0	141.5 (3594)	47.0 (1194)	105/32 (83)	161,000 @ 110 (73,000 @ 7.5)	458 (669)
50/80R57	H4	MH4270	No Sipes	E-4	257 B	2 *	34.00	5.0	141.5 (3594)	47.0 (1194)	105/32 (83)	161,000 @ 110 (73,000 @ 7.5)	725 (1059)
50/80R57	W4	MW4270	No Sipes	E-4	257 B	2 *	34.00	5.0	141.5 (3594)	47.0 (1194)	105/32 (83)	161,000 @ 110 (73,000 @ 7.5)	580 (847)
50/80R57	C4	MF4270	No Sipes	E-4	257 B	2 *	34.00	5.0	141.5 (3594)	47.0 (1194)	105/32 (83)	161,000 @ 110 (73,000 @ 7.5)	435 (635)
46/90R57	HV	MHV276	Sipes	E-4	252 B	2 *	32.00	6.0	142.1 (3609)	46.0 (1168)	105/32 (83)	139,000 @ 105 (63,000 @ 7.3)	853 (1246)
46/90R57	WV	MWV276	Sipes	E-4	252 B	2 *	32.00	6.0	142.1 (3609)	46.0 (1168)	105/32 (83)	139,000 @ 105 (63,000 @ 7.3)	683 (996)
46/90R57	CV	MFV276	Sipes	E-4	252 B	2 *	32.00	6.0	142.1 (3609)	46.0 (1168)	105/32 (83)	139,000 @ 105 (63,000 @ 7.3)	512 (747)
46/90R57	H2	MH2276	No Sipes	E-4	252 B	2 *	32.00	6.0	142.1 (3609)	46.0 (1168)	105/32 (83)	139,000 @ 105 (63,000 @ 7.3)	810 (1183)
46/90R57	W2	MW2276	No Sipes	E-4	252 B	2 *	32.00	6.0	142.1 (3609)	46.0 (1168)	105/32 (83)	139,000 @ 105 (63,000 @ 7.3)	648 (947)
46/90R57	C2	MF2276	No Sipes	E-4	252 B	2 *	32.00	6.0	142.1 (3609)	46.0 (1168)	105/32 (83)	139,000 @ 105 (63,000 @ 7.3)	486 (710)

Radial OTR

007 MFT Continued

Tire Size	Compound/ Construction	Catalog Number	Sipes/ No Sipes	Industry Code	Load/ Speed Index	Load Rating	Rim Width Code	Flange Height Code	Outside Diameter in (mm)	Section Width in (mm)	Tread Depth in (mm)	Load @ Inflation lbs @ PSI (kg @ bar)	TMPH (TKPH)
40.00R57	HV	MHV240	Sipes	E-4	250 B	2 *	29.00, 32.00	6.0	142.1 (3609)	43.2 (1097)	105/32 (83)	132,500 @ 105 (60,000 @ 7.3)	813 (1186)
40.00R57	WV	MWV240	Sipes	E-4	250 B	2 *	29.00, 32.00	6.0	142.1 (3609)	43.2 (1097)	105/32 (83)	132,500 @ 105 (60,000 @ 7.3)	650 (949)
40.00R57	CV	MFV240	Sipes	E-4	250 B	2 *	29.00, 32.00	6.0	142.1 (3609)	43.2 (1097)	105/32 (83)	132,500 @ 105 (60,000 @ 7.3)	488 (712)
40.00R57	H2	MH2240	No Sipes	E-4	250 B	2 *	29.00, 32.00	6.0	142.1 (3609)	43.2 (1097)	105/32 (83)	132,500 @ 105 (60,000 @ 7.3)	772 (1127)
40.00R57	W2	MW2240	No Sipes	E-4	250 B	2 *	29.00, 32.00	6.0	142.1 (3609)	43.2 (1097)	105/32 (83)	132,500 @ 105 (60,000 @ 7.3)	618 (902)
40.00R57	C2	MF2240	No Sipes	E-4	250 B	2 *	29.00, 32.00	6.0	142.1 (3609)	43.2 (1097)	105/32 (83)	132,500 @ 105 (60,000 @ 7.3)	463 (676)
40.00R57	HR*	MHV240	Sipes	E-4	250 B	2 *	29.00, 32.00	6.0	142.1 (3609)	43.2 (1097)	105/32 (83)	132,500 @ 105 (60,000 @ 7.3)	813 (1186)
40.00R57	WR*	MWV240	Sipes	E-4	250 B	2 *	29.00, 32.00	6.0	142.1 (3609)	43.2 (1097)	105/32 (83)	132,500 @ 105 (60,000 @ 7.3)	650 (949)
40.00R57	CR*	MFV240	Sipes	E-4	250 B	2 *	29.00, 32.00	6.0	142.1 (3609)	43.2 (1097)	105/32 (83)	132,500 @ 105 (60,000 @ 7.3)	488 (712)
40.00R57	H4*	MH2240	No Sipes	E-4	250 B	2 *	29.00, 32.00	6.0	142.1 (3609)	43.2 (1097)	105/32 (83)	132,500 @ 105 (60,000 @ 7.3)	772 (1127)
40.00R57	W4*	MW2240	No Sipes	E-4	250 B	2 *	29.00, 32.00	6.0	142.1 (3609)	43.2 (1097)	105/32 (83)	132,500 @ 105 (60,000 @ 7.3)	618 (902)
40.00R57	C4*	MF2240	No Sipes	E-4	250 B	2 *	29.00, 32.00	6.0	142.1 (3609)	43.2 (1097)	105/32 (83)	132,500 @ 105 (60,000 @ 7.3)	463 (676)
37.00R57	HV	MHV237	Sipes	E-4+	245 B	2 *	27.00, 29.00	6.0	136.0 (3455)	40.0 (1016)	125/32 (99)	113,500 @ 105 (51,500 @ 7.3)	716 (1046)
37.00R57	WV	MWV237	Sipes	E-4+	245 B	2 *	27.00, 29.00	6.0	136.0 (3455)	40.0 (1016)	125/32 (99)	113,500 @ 105 (51,500 @ 7.3)	573 (837)
37.00R57	CV	MFV237	Sipes	E-4+	245 B	2 *	27.00, 29.00	6.0	136.0 (3455)	40.0 (1016)	125/32 (99)	113,500 @ 105 (51,500 @ 7.3)	430 (628)
37.00R57	H2	MH2237	No Sipes	E-4+	245 B	2 *	27.00, 29.00	6.0	136.0 (3455)	40.0 (1016)	125/32 (99)	113,500 @ 105 (51,500 @ 7.3)	681 (994)
37.00R57	W2	MW2237	No Sipes	E-4+	245 B	2 *	27.00, 29.00	6.0	136.0 (3455)	40.0 (1016)	125/32 (99)	113,500 @ 105 (51,500 @ 7.3)	545 (795)
37.00R57	C2	MF2237	No Sipes	E-4+	245 B	2 *	27.00, 29.00	6.0	136.0 (3455)	40.0 (1016)	125/32 (99)	113,500 @ 105 (51,500 @ 7.3)	408 (596)
33.00R51	HE	MHT2R3	Sipes	E-4	235 B	2 *	24.00	5.0	120.5 (3061)	35.2 (894)	98/32 (78)	85,500 @ 105 (38,750 @ 7.3)	568 (829)
33.00R51	WE	MWT2R3	Sipes	E-4	235 B	2 *	24.00	5.0	120.5 (3061)	35.2 (894)	98/32 (78)	85,500 @ 105 (38,750 @ 7.3)	470 (687)
33.00R51	CE	MFT2R3	Sipes	E-4	235 B	2 *	24.00	5.0	120.5 (3061)	35.2 (894)	98/32 (78)	85,500 @ 105 (38,750 @ 7.3)	353 (515)
33.00R51	H2	MH22R3	No Sipes	E-4	235 B	2 *	24.00	5.0	120.5 (3061)	35.2 (894)	98/32 (78)	85,500 @ 105 (38,750 @ 7.3)	540 (788)
33.00R51	W2	MW22R3	No Sipes	E-4	235 B	2 *	24.00	5.0	120.5 (3061)	35.2 (894)	98/32 (78)	85,500 @ 105 (38,750 @ 7.3)	447 (652)
33.00R51	C2	MF22R3	No Sipes	E-4	235 B	2 *	24.00	5.0	120.5 (3061)	35.2 (894)	98/32 (78)	85,500 @ 105 (38,750 @ 7.3)	335 (489)
27.00R49	HE	MHT2R9	Sipes	E-4	223 B	2 *	19.50	4.0	106.7 (2703)	28.6 (726)	86/32 (68)	60,000 @ 105 (27,250 @ 7.3)	433 (631)
27.00R49	WE	MWT2R9	Sipes	E-4	223 B	2 *	19.50	4.0	106.7 (2703)	28.6 (726)	86/32 (68)	60,000 @ 105 (27,250 @ 7.3)	346 (505)
27.00R49	CE	MFT2R9	Sipes	E-4	223 B	2 *	19.50	4.0	106.7 (2703)	28.6 (726)	86/32 (68)	60,000 @ 105 (27,250 @ 7.3)	260 (379)
27.00R49	H2	MH22R9	No Sipes	E-4	223 B	2 *	19.50	4.0	106.7 (2703)	28.6 (726)	86/32 (68)	60,000 @ 105 (27,250 @ 7.3)	411 (600)
27.00R49	W2	MW22R9	No Sipes	E-4	223 B	2 *	19.50	4.0	106.7 (2703)	28.6 (726)	86/32 (68)	60,000 @ 105 (27,250 @ 7.3)	329 (480)
27.00R49	C2	MF22R9	No Sipes	E-4	223 B	2 *	19.50	4.0	106.7 (2703)	28.6 (726)	86/32 (68)	60,000 @ 105 (27,250 @ 7.3)	247 (360)

* Rounded shoulder design



Titan TG2 (G-2)

- Exceptional traction design
- Non-directional tread pattern provides long tread life
- Open tread pattern provides excellent self-cleaning

Tire Size	Compound/ Construction	Catalog Number	Industry Code	Industry Code	Load/ Speed Index	Load Rating	Rim Width Code	Flange Height Code	Outside Diameter in (mm)	Section Width in (mm)	Section Width Loaded in (mm)	Static Loaded Radius in (mm)	Tread Depth in (mm)	Load/Inflation lbs @ psi (kg @ bar)
14.00R24TG	WE	PGW1R4	G-2	153 A8	1 *	10.00VA	1.7	53.5 (1359)	14.6 (371)	16.9 (429)	24.1 (612)	198 (1277)	32/32 (25)	8,050 @ 54 (3,650 @ 3.8)



Tread A



Tread B

Titan TGS2 (G-2) or (G-2/L-2)

- All season tread pattern
- Aggressive tread pattern provides excellent traction and self-cleaning on all surfaces
- Siping provides excellent traction in all conditions, especially snow, ice, and mud

Tire Size	Compound/Construction	Tread Design	Catalog Number	Industry Code	Load/ Speed Index	Load Rating	Rim Width Code	Flange Height Code	Outside Diameter in (mm)	Section Width in (mm)	Width Loaded in (mm)	Static Loaded Radius in (mm)	Gross Footprint Area in ² (cm ²)	Tread Depth in (mm)	Load/Inflation lbs @ PSI (kg @ bar)
14.00R24TG	WE	A	PSW1R4	G-2	153 A8	1 *	10.00VA	1.7	53.4 (1356)	15.0 (381)	17.2 (437)	24.3 (617)	173 (1116)	32/32 (25)	8,050 @ 54 (3,650 @ 3.8)
17.5R25	WE	B	ESWA17	G-2	153 A8	1 *	14.00	1.5	53.0 (1346)	18.0 (457)	20.2 (513)	23.9 (607)	242 (1561)	32/32 (25)	8,050 @ 44 (3,650 @ 3.0)
				L-2	176 A2	1 *	14.00	1.5	53.2 (1351)	18.3 (465)	20.8 (528)	23.7 (602)	248 (1603)	32/32 (25)	15,700 @ 73 (7,100 @ 5.0)
20.5R25	WE	B	ESWA21	G-2	161 A8	1 *	17.00	2.0	58.3 (1481)	21.4 (542)	24.5 (622)	165 (1065)	296 (1908)	36/32 (29)	10,200 @ 44 (4,625 @ 3.0)
				L-2	186 A2	1 *	17.00	2.0	58.4 (1483)	21.5 (546)	25.4 (644)	224 (1448)	370 (2386)	36/32 (29)	20,900 @ 73 (9,500 @ 5.0)



Titan TGL2 (G-2/L-2)

- Non-directional tread pattern provides long tread life
- Open tread pattern provides excellent self-cleaning and traction

Tire Size	Compound/Construction	Catalog Number	Industry Code	Load/ Speed Index	Load Rating	Rim Width Code	Flange Height Code	Outside Diameter in (mm)	Section Width in (mm)	Width Loaded in (mm)	Static Loaded Radius in (mm)	Gross Footprint Area in ² (cm ²)	Tread Depth in (mm)	Load/Inflation lbs @ PSI (kg @ bar)
17.5R25	WE	EUWA17	G-2	153 A8	1 *	14.00	1.5	52.6 (1337)	17.5 (445)	20.0 (507)	24.0 (610)	191 (1235)	35/32 (28)	15,700 @ 73 (7,100 @ 5.0)
			L-2	176 A2	1 *	14.00	1.5	52.6 (1337)	17.5 (445)	19.5 (496)	23.5 (596)	230 (1487)	35/32 (28)	8,050 @ 44 (3,650 @ 3.0)



Titan TGD2 (E-2/L-2)

- Directional tread design for excellent forward traction
- Center riding rib for smooth ride and even wear

Tire Size	Compound/Construction	Catalog Number	Industry Code	Load/ Speed Index	Load Rating	Rim Width Code	Flange Height Code	Outside Diameter in (mm)	Section Width in (mm)	Width Loaded in (mm)	Static Loaded Radius in (mm)	Gross Footprint Area in ² (cm ²)	Tread Depth in (mm)	Load/Inflation lbs @ PSI (kg @ bar)
20.5R25	CE	EDTB21	E-2	177 B	2 *	17.00	2.0	58.3 (1480)	20.5 (521)	22.0 (558)	26.3 (667)	271 (1750)	36/32 (29)	16,100 @ 76 (7,300 @ 5.3)
			L-2	186 A2	1 *	17.00	2.0	58.3 (1480)	20.5 (521)	22.5 (571)	25.6 (650)	333 (2150)	36/32 (29)	20,900 @ 73 (9,500 @ 5.0)
23.5R25	CE	EDTB23	E-2	185 B	2 *	19.50	2.5	63.0 (1599)	23.5 (597)	26.4 (670)	28.3 (720)	336 (2170)	42/32 (33)	20,400 @ 76 (9,250 @ 5.3)
			L-2	195 A2	1 *	19.50	2.5	63.0 (1599)	23.5 (597)	27.0 (685)	27.5 (698)	422 (2720)	42/32 (33)	26,800 @ 73 (12,150 @ 5.0)

Radial OTR



Titan STL3 (E-3/L-3) Dual Purpose Tire

- Non-directional tread pattern
- Center riding rib for smooth ride and long, even wear
- Full-width shoulder lug for excellent traction and lateral stability
- Additional compounds available upon request

Tire Size	Compound/ Construction	Catalog Number	Industry Code	Load/ Speed Index	Load Rating	Rim Width Code	Flange Height Code	Outside Diameter in (mm)	Section Width in (mm)	Section Width Loaded in (mm)	Static Loaded Radius in (mm)	Gross Footprint Area in ² (cm ²)	Tread Depth in (mm)	Load/Inflation lbs @ PSI (kg @ bar)
20.5R25	CE	ERTB21	E-3	177 B	2 *	17.00	2.0	58.7 (1490)	20.5 (521)	22.0 (558)	26.5 (672)	269 (1738)	42/32 (33)	16,100 @ 76 (7,300 @ 5.3)
			L-3	186 A2	1 *	17.00	2.0	58.7 (1490)	20.5 (521)	22.5 (571)	25.8 (655)	325 (2096)	42/32 (33)	16,100 @ 76 (7,300 @ 5.3)
23.5R25	CE	ERTB23	E-3	185 B	2 *	19.50	2.5	63.1 (1602)	23.5 (597)	26.4 (670)	28.4 (721)	338 (2180)	44/32 (35)	20,400 @ 76 (9,250 @ 5.3)
			L-3	195 A2	1 *	19.50	2.5	63.1 (1602)	23.5 (597)	27.0 (685)	27.5 (699)	423 (2726)	44/32 (35)	26,800 @ 73 (12,150 @ 5.0)
23.5R25	WE	ERWB23	E-3	185 B	2 *	19.50	2.5	63.1 (1602)	23.5 (597)	26.4 (670)	28.4 (721)	338 (2180)	44/32 (35)	20,400 @ 76 (9,250 @ 5.3)
			L-3	195 A2	1 *	19.50	2.5	63.1 (1602)	23.5 (597)	27.0 (685)	27.5 (699)	423 (2726)	44/32 (35)	26,800 @ 73 (12,150 @ 5.0)
26.5R25	CE	ERTB27	E-3	193 B	2 *	22.00	3.0	68.4 (1737)	26.5 (673)	30.1 (765)	30.5 (775)	475 (3064)	48/32 (38)	25,400 @ 76 (11,500 @ 5.3)
			L-3	202 A2	1 *	22.00	3.0	68.4 (1737)	26.5 (673)	30.9 (785)	29.5 (749)	544 (3512)	48/32 (38)	33,100 @ 73 (15,000 @ 5.0)
26.5R25	WE	ERWB27	E-3	193 B	2 *	22.00	3.0	68.4 (1737)	26.5 (673)	30.1 (765)	30.5 (775)	475 (3064)	48/32 (38)	25,400 @ 76 (11,500 @ 5.3)
			L-3	202 A2	1 *	22.00	3.0	68.4 (1737)	26.5 (673)	30.9 (785)	29.5 (749)	544 (3512)	48/32 (38)	33,100 @ 73 (15,000 @ 5.0)
29.5R25	CE	ERTB29	E-3	200 B	2 *	25.00	3.5	73.0 (1855)	29.5 (749)	33.1 (841)	32.6 (829)	541 (3493)	55/32 (44)	30,900 @ 76 (14,000 @ 5.3)
			L-3	208 A2	1 *	25.00	3.5	73.0 (1855)	29.5 (749)	34.0 (864)	31.5 (801)	607 (3917)	55/32 (44)	39,700 @ 7.3 (18,000 @ 5.0)
29.5R25	WE	ERWB29	E-3	200 B	2 *	25.00	3.5	73.0 (1855)	29.5 (749)	33.1 (841)	32.6 (829)	541 (3493)	55/32 (44)	30,900 @ 76 (14,000 @ 5.3)
			L-3	208 A2	1 *	25.00	3.5	73.0 (1855)	29.5 (749)	34.0 (864)	31.5 (801)	607 (3917)	55/32 (44)	39,700 @ 7.3 (18,000 @ 5.0)
750/65R25	WE	ERWBW1	E-3	190 B	2 *	24.00	3.0	63.2 (1605)	30.1 (765)	32.1 (815)	28.2 (716)	465 (3001)	58/32 (46)	23,400 @ 62 (10,600 @ 4.3)
			L-3	202 A2	1 *	24.00	3.0	63.3 (1608)	30.1 (765)	32.7 (831)	27.3 (693)	519 (3348)	58/32 (46)	33,100 @ 69 (15,000 @ 4.8)
29.5R34.5	CE	5RTB34	E-3	200 B	2 *	25.00	---	73.0 (1855)	29.5 (749)	---	---	---	55/32 (44)	30,900 @ 76 (14,000 @ 5.3)
			L-3	208 A2	1 *	25.00	---	73.0 (1855)	29.5 (749)	---	---	---	---	55/32 (44)
29.5R34.5	WE	5RWB34	E-3	200 B	2 *	25.00	---	73.0 (1855)	29.5 (749)	---	---	---	55/32 (44)	30,900 @ 76 (14,000 @ 5.3)
			L-3	208 A2	1 *	25.00	---	73.0 (1855)	29.5 (749)	---	---	---	---	55/32 (44)



Titan MXL (E-3/L-3)

- Aggressive tread for optimal traction
- Sturdy tread elements for maximum torque transmission

Tire Size	Catalog Number	Industry Code	Load/ Speed Index	Load Rating	Rim Width Code	Flange Height Code	Outside Diameter in (mm)	Section Width in (mm)	Section Width Loaded in (mm)	Static Loaded Radius in (mm)	Gross Footprint Area in ² (cm ²)	Tread Depth in (mm)	Load/Inflation lbs @ PSI (kg @ bar)
17.5R25	43P117	E-3	157 B	1 *	14.00	1.5	53.9 (1369)	17.7 (450)	19.9 (505)	24.0 (610)	252 (1626)	39/32 (31)	9,100 @ 54 (4,125 @ 3.8)
		L-3	176 A2	1 *	14.00	1.5	53.9 (1369)	17.7 (450)	19.9 (505)	24.0 (610)	252 (1626)	39/32 (31)	15,700 @ 73 (7,100 @ 5.0)
20.5R25	43P121	E-3	168 B	1 *	17.00	2.0	59.5 (1511)	20.7 (526)	22.9 (582)	26.4 (671)	374 (2413)	49/32 (39)	12,300 @ 54 (5,600 @ 3.8)
		L-3	186 A2	1 *	17.00	2.0	59.5 (1511)	20.7 (526)	22.9 (582)	26.4 (671)	374 (2413)	49/32 (39)	20,900 @ 73 (9,500 @ 5.0)
23.5R25	43P123	E-3	176 B	1 *	19.50	2.5	64.0 (1626)	24.9 (632)	27.0 (686)	28.5 (724)	400 (2581)	51/32 (41)	15,700 @ 54 (7,100 @ 3.8)
		L-3	195 A2	1 *	19.50	2.5	64.0 (1626)	25.0 (635)	27.9 (709)	28.5 (724)	460 (2968)	51/32 (41)	26,800 @ 73 (12,150 @ 5.0)
26.5R25	43P127	E-3	184 B	1 *	22.00	3.0	68.6 (1742)	27.7 (704)	30.7 (780)	31.3 (795)	435 (2806)	55/32 (44)	19,800 @ 54 (9,000 @ 3.8)
		L-3	202 A2	1 *	22.00	3.0	69.0 (1753)	27.8 (706)	31.3 (795)	30.5 (775)	509 (3284)	55/32 (44)	33,100 @ 73 (15,000 @ 5.0)



Titan STL2+ (E-3T/L-3T) Dual Purpose Tire

- 130% level tread depth provides long tread life
- Open, non-directional tread pattern provides excellent self-cleaning
- Bar lug design for rock and traction

Tire Size	Compound/ Construction	Catalog Number	Industry Code	Load/ Speed Index	Load Rating	Rim Width Code	Flange Height Code	Outside Diameter in (mm)	Section Width in (mm)	Section Width Loaded in (mm)	Static Loaded Radius in (mm)	Gross Footprint Area in ² (cm ²)	Tread Depth in (mm)	Load/Inflation lbs @ PSI (kg @ bar)
23.5R25	CE	EPTB23	E-3T	185 B	2 *	19.50	2.5	63.7 (1618)	23.5 (597)	26.4 (671)	28.7 (729)	341 (2200)	53/32 (42)	20,400 @ 76 (9,250 @ 5.3)
			L-3T	195 A2	1 *	19.50	2.5	63.7 (1618)	23.5 (597)	27.0 (686)	27.8 (706)	426 (2748)	53/32 (42)	26,800 @ 73 (12,150 @ 5.0)
26.5R25	CE	EPTB27	E-3T	193 B	2 *	22.00	3.0	68.7 (1745)	26.5 (673)	30.1 (765)	30.7 (780)	481 (3103)	56/32 (45)	25,400 @ 76 (11,500 @ 5.3)
			L-3T	202 A2	1 *	22.00	3.0	68.7 (1745)	26.5 (673)	30.9 (785)	29.7 (754)	550 (3548)	56/32 (45)	33,100 @ 73 (15,000 @ 5.0)
26.5R25	WE	EPWB27	E-3T	193 B	2 *	22.00	3.0	68.7 (1745)	26.5 (673)	30.1 (765)	30.7 (780)	481 (3103)	56/32 (45)	25,400 @ 76 (11,500 @ 5.3)
			L-3T	202 A2	1 *	22.00	3.0	68.7 (1745)	26.5 (673)	30.9 (785)	29.7 (754)	550 (3548)	56/32 (45)	33,100 @ 73 (15,000 @ 5.0)
29.5R25	CE	EPTB29	E-3T	200 B	2 *	25.00	3.5	73.3 (1862)	29.5 (749)	33.1 (841)	32.8 (833)	543 (3503)	60/32 (48)	30,900 @ 76 (14,000 @ 5.3)
			L-3T	208 A2	1 *	25.00	3.5	73.3 (1862)	29.5 (749)	34.0 (864)	31.7 (805)	608 (3923)	60/32 (48)	39,700 @ 73 (18,000 @ 5.0)
29.5R25	WE	EPWB29	E-3T	200 B	2 *	25.00	3.5	73.3 (1862)	29.5 (749)	33.1 (841)	32.8 (833)	543 (3503)	60/32 (48)	30,900 @ 76 (14,000 @ 5.3)
			L-3T	208 A2	1 *	25.00	3.5	73.3 (1862)	29.5 (749)	34.0 (864)	31.7 (805)	608 (3923)	60/32 (48)	39,700 @ 73 (18,000 @ 5.0)

Radial OTR



Titan DTH4 (E-4) Haul Truck Tire

- Deep tread depth for long tread life
- Solid center and large contact area provide damage resistance
- Self-cleaning grooves provide excellent traction
- Additional compounds available upon request

Tire Size	Compound/ Construction	Catalog Number	Industry Code	Load/ Speed Index	Load Rating	Rim Width Code	Flange Height Code	Outside Diameter in (mm)	Section Width in (mm)	Section Width Loaded in (mm)	Static Loaded Radius in (mm)	Gross Footprint Area in ² (cm ²)	Tread Depth in (mm)	Rated Load @Inflation lbs @ PSI (kg @ bar)	TMPH (TKPH)
18.00R33	HE	EHH2R8	E-4	191 B	2 *	13.00	2.5	74.0 (1880)	21.2 (539)	23.4 (594)	33.9 (861)	302 (1948)	62/32 (49)	24,000 @ 102 (10,900 @ 7.0)	---
18.00R33	WE	EHW2R8	E-4	191 B	2 *	13.00	2.5	74.0 (1880)	21.2 (539)	23.4 (594)	33.9 (861)	302 (1948)	62/32 (49)	24,000 @ 102 (10,900 @ 7.0)	---
18.00R33	CE	EHF2R8	E-4	191 B	2 *	13.00	2.5	74.0 (1880)	21.2 (539)	23.4 (594)	33.9 (861)	302 (1948)	62/32 (49)	24,000 @ 102 (10,900 @ 7.0)	---
24.00R35	HE	EHH2R7	E-4	209 B	2 *	17.00	3.5	85.8 (2179)	26.7 (678)	29.9 (760)	39.1 (993)	533 (3435)	70/32 (56)	40,800 @ 102 (18,500 @ 7.0)	310 (453)
24.00R35	WE	EHW2R7	E-4	209 B	2 *	17.00	3.5	85.8 (2179)	26.7 (678)	29.9 (760)	39.1 (993)	533 (3435)	70/32 (56)	40,800 @ 102 (18,500 @ 7.0)	225 (329)
24.00R35	CE	EHF2R7	E-4	209 B	2 *	17.00	3.5	85.8 (2179)	26.7 (678)	29.9 (760)	39.1 (993)	533 (3435)	70/32 (56)	40,800 @ 102 (18,500 @ 7.0)	168 (245)
27.00R49	HE	EHH2R9	E-4	223 B	2 *	19.50	4.0	107.9 (2741)	28.7 (729)	32.8 (833)	49.5 (1258)	722 (4658)	95/32 (75)	60,000 @ 105 (27,250 @ 7.3)	---
27.00R49	WE	EHW2R9	E-4	223 B	2 *	19.50	4.0	107.9 (2741)	28.7 (729)	32.8 (833)	49.5 (1258)	722 (4658)	95/32 (75)	60,000 @ 105 (27,250 @ 7.3)	---
27.00R49	CE	EHF2R9	E-4	223 B	2 *	19.50	4.0	107.9 (2741)	28.7 (729)	32.8 (833)	49.5 (1258)	722 (4658)	95/32 (75)	60,000 @ 105 (27,250 @ 7.3)	---
33.00R51	HE	EHH2R3	E-4	235 B	2 *	24.00	5.0	120.0 (3048)	34.1 (866)	---	---	---	106/32 (84)	85,500 @ 105 (38,750 @ 7.3)	432 (631)
33.00R51	WE	EHW2R3	E-4	235 B	2 *	24.00	5.0	120.0 (3048)	34.1 (866)	---	---	---	106/32 (84)	85,500 @ 105 (38,750 @ 7.3)	346 (505)
33.00R51	CE	EHF2R3	E-4	235 B	2 *	24.00	5.0	120.0 (3048)	34.1 (866)	---	---	---	106/32 (84)	85,500 @ 105 (38,750 @ 7.3)	259 (378)
40.00R57	HE	EHH240	E-4	250 B	2 *	29.00,32.00	6.0	142.1 (3609)	43.2 (1097)	50.0 (1270)	63.8 (1621)	---	105/32 (83)	132,500 @ 105 (60,000 @ 7.3)	729 (1064)
40.00R57	HR*	RHH240	E-4	250 B	2 *	29.00,32.00	6.0	142.1 (3609)	43.2 (1097)	50.0 (1270)	63.8 (1621)	---	105/32 (83)	132,500 @ 105 (60,000 @ 7.3)	729 (1064)
40.00R57	WE	EHW240	E-4	250 B	2 *	29.00,32.00	6.0	142.1 (3609)	43.2 (1097)	50.0 (1270)	63.8 (1621)	---	105/32 (83)	132,500 @ 105 (60,000 @ 7.3)	583 (851)
40.00R57	WR*	RHW240	E-4	250 B	2 *	29.00,32.00	6.0	142.1 (3609)	43.2 (1097)	50.0 (1270)	63.8 (1621)	---	105/32 (83)	132,500 @ 105 (60,000 @ 7.3)	583 (851)
40.00R57	CE	EHF240	E-4	250 B	2 *	29.00,32.00	6.0	142.1 (3609)	43.2 (1097)	50.0 (1270)	63.8 (1621)	---	105/32 (83)	132,500 @ 105 (60,000 @ 7.3)	437 (638)
56/80R63	HR*	RHH26M	E-4	266 B	2 *	41.00	5.0	152.6E (3876)	56.0E (1422)	---	---	---	125/32 (99)	209,500 @ 110 (95,000 @ 7.5)	864 (1261)
56/80R63	WR*	RHW26M	E-4	266 B	2 *	41.00	5.0	152.6E (3876)	56.0E (1422)	---	---	---	125/32 (99)	209,500 @ 110 (95,000 @ 7.5)	691 (1009)
56/80R63	CR*	RHF26M	E-4	266 B	2 *	41.00	5.0	152.6E (3876)	56.0E (1422)	---	---	---	125/32 (99)	209,500 @ 110 (95,000 @ 7.5)	518 (757)

E - Estimated

*Rounded shoulder design



Titan DTE4 (E-4) Haul Truck Tire

- Deep tread depth for long tread life
- Deep lug tread pattern provides excellent traction
- Open, non-directional tread pattern provides excellent self-cleaning
- Additional compounds available upon request

Tire Size	Compound/ Construction	Catalog Number	Industry Code	Load/ Speed Index	Load Rating	Rim Width Code	Flange Height Code	Outside Diameter in (mm)	Section Width in (mm)	Section Width Loaded in (mm)	Static Loaded Radius in (mm)	Gross Footprint Area in ² (cm ²)	Tread Depth in (mm)	Rated Load @Inflation lbs @ PSI (kg @ bar)	TMPH (TKPH)
18.00R33	HE	EEH2R8	E-4T	191 B	2 *	13.00	2.5	74.5 (1887)	20.1 (511)	22.2 (564)	33.9 (861)	364 (2348)	68/32 (54)	24,000 @ 102 (10,900 @ 7.0)	---
18.00R33	HE	EEH2R8	E-4T	191 B	2 *	13.00	2.5	74.5 (1887)	20.1 (511)	22.2 (564)	33.9 (861)	364 (2348)	68/32 (54)	24,000 @ 102 (10,900 @ 7.0)	---
18.00R33	HE	EEH2R8	E-4T	191 B	2 *	13.00	2.5	74.5 (1887)	20.1 (511)	22.2 (564)	33.9 (861)	364 (2348)	68/32 (54)	24,000 @ 102 (10,900 @ 7.0)	---

Titan DTE4 (E-4) Haul Truck Tire continued

Tire Size	Compound/Construction	Catalog Number	Industry Code	Load/Speed Index	Load Rating	Rim Width Code	Flange Height Code	Outside Diameter in (mm)	Section Width in (mm)	Section Width Loaded in (mm)	Static Loaded Radius in (mm)	Gross Footprint Area in ² (cm ²)	Tread Depth in (mm)	Rated Load @ Inflation lbs @ PSI (kg @ bar)	TMPH (TKPH)
27.00R49	HE	EEH2R9	E-4T	223 B	2 *	19.50	4.0	107.9(2741)	28.7 (729)	32.6 (828)	49.3 (1252)	819 (5284)	95/32 (75)	60,000 @ 105 (27,250 @ 7.3)	458 (669)
27.00R49	WE	EEW2R9	E-4T	223 B	2 *	19.50	4.0	107.9(2741)	28.7 (729)	32.6 (828)	49.3 (1252)	819 (5284)	95/32 (75)	60,000 @ 105 (27,250 @ 7.3)	382 (558)
27.00R49	CE	EEF2R9	E-4T	223 B	2 *	19.50	4.0	107.9(2741)	28.7 (729)	32.6 (828)	49.3 (1252)	819 (5284)	95/32 (75)	60,000 @ 105 (27,250 @ 7.3)	286 (418)
33.00R51	HE	EEH2R3	E-4T	235 B	2 *	24.00	5.0	120.0 (3048)	34.1 (866)	39.1 (993)	54.3 (1379)	1106 (7136)	108/32 (86)	85,500 @ 105 (38,750 @ 7.3)	641 (936)
33.00R51	WE	EEW2R3	E-4T	235 B	2 *	24.00	5.0	120.0 (3048)	34.1 (866)	39.1 (993)	54.3 (1379)	1106 (7136)	106/32 (84)	85,500 @ 105 (38,750 @ 7.3)	513 (749)
33.00R51	CE	EEF2R3	E-4T	235 B	2 *	24.00	5.0	120.0 (3048)	34.1 (866)	39.1 (993)	54.3 (1379)	1106 (7136)	106/32 (84)	85,500 @ 105 (38,750 @ 7.3)	360 (526)

Titan LDR 250 (L-5) • Extra deep tread provides excellent rock type damage resistance and long tread life • Open non-directional tread pattern provides all around traction with excellent self-cleaning



Tread A



Tread B



Tread C



Tread D

Tire Size	Tread Style	Compound/Construction	Catalog Number	Industry Code	Load/Speed Index	Load Rating	Rim Width Code	Flange Height Code	Outside Diameter in (mm)	Section Width in (mm)	Section Width Loaded in (mm)	Static Loaded Radius in (mm)	Gross Footprint Area in ² (cm ²)	Tread Depth in (mm)	Rated Load @ Inflation lbs. @ PSI (kg @ bar)
29.5R29	C	WE	LWG2U2	L-5	218 A2	2 *	25.00	3.5	77.1 (1958)	29.8 (757)	33.1 (841)	34.2 (869)	705 (4548)	121/32 (96)	52,000 @ 94 (23,950 @ 6.5)
29.5R29	C	CE	LFG2U2	L-5	218 A2	2 *	25.00	3.5	77.1 (1958)	29.8 (757)	33.1 (841)	34.2 (869)	705 (4548)	121/32 (96)	52,000 @ 94 (23,950 @ 6.5)
29.5R29	C	CE (UGM)	LUG2U2	L-5	218 A2	2 *	25.00	3.5	77.1 (1958)	29.8 (757)	33.1 (841)	34.2 (869)	705 (4548)	121/32 (96)	52,000 @ 94 (23,950 @ 6.5)
29.5R29	D	WV	LWV2U2	L-5	218 A2	2 *	25.00	3.5	77.1 (1958)	29.8 (757)	33.1 (841)	34.2 (869)	705 (4548)	121/32 (96)	52,000 @ 94 (23,950 @ 6.5)
29.5R29	D	CV	LFV2U2	L-5	218 A2	2 *	25.00	3.5	77.1 (1958)	29.8 (757)	33.1 (841)	34.2 (869)	705 (4548)	121/32 (96)	52,000 @ 94 (23,950 @ 6.5)
35/65R33	A	WE	LFT26K	L-5	224 A2	2 *	28.00	3.5	81.6 (2073)	34.1 (866)	37.7 (958)	36.2 (919)	730 (4710)	115/32 (91)	61,500 @ 94 (28,00 @ 6.5)
35/65R33	A	CE	LTT26K	L-5	224 A2	2 *	28.00	3.5	81.6 (2073)	34.1 (866)	37.7 (958)	36.2 (919)	730 (4710)	115/32 (91)	61,500 @ 94 (28,00 @ 6.5)
45/65R45	A	WE	LFT26P	L-5	245 A2	2 *	36.00	4.5	106.9E (2715)	42.4E (1077)	44.9E (1140)	48.1E (1222)	1193E (7695)	140/32 (111)	113,500 @ 94 (51,500 @ 6.5)
45/65R45	A	CE	LTT26P	L-5	245 A2	2 *	36.00	4.5	106.9E (2715)	42.4E (1077)	44.9E (1140)	48.1E (1222)	1193E (7695)	140/32 (111)	113,500 @ 94 (51,500 @ 6.5)
50/65R51	B	WE	LFT2G6	L-5	253 A2	2 *	40.00	4.5	120.0E (3048)	50.0E (1270)	53.0E (1346)	54.5E (1384)	1500E (9677)	160/32 (127)	143,500 @ 94 (65,500 @ 6.5)
50/65R51	B	CE	LTT2G6	L-5	253 A2	2 *	40.00	4.5	120.0E (3048)	50.0E (1270)	53.0E (1346)	54.5E (1384)	1500E (9677)	160/32 (127)	143,500 @ 94 (65,500 @ 6.5)

E - Estimated



Titan LDR 150 (L-4)

- Extra deep tread provides excellent rock type damage resistance and long tread life
- Open non-directional tread pattern provides all around traction with excellent self-cleaning

Tire Size	Compound/Construction	Catalog Number	Industry Code	Load/Speed Index	Load Rating	Rim Width Code	Flange Height Code	Outside Diameter in (mm)	Section Width in (mm)	Section Width Loaded in (mm)	Static Loaded Radius in (mm)	Gross Footprint Area in ² (cm ²)	Tread Depth in (mm)	Load/Inflation lbs @ PSI (kg @ bar)
58/80R63	WE	LF4258	L-4	276 A2	2 *	47.00	5.0	152.0 (3861)	54.9 (1395)	63.8 (1621)	66.2 (1681)	2665 (17,194)	119/32 (95)	275,500 @ 102 (125,000 @ 7.0)

Bias Earthmoving

Earthmoving Service Tires

The “E” series type tires are referred to as haulage tires in off-the-road earthmoving applications. These tires are designed to transport materials over unimproved surfaces at speeds under 30 mph and short distances, generally 2.5 miles one way.

E-1 rib design tires are normally used on free-rolling positions on quarry, mining and heavy road building equipment.

E-2 traction design tires have open tread patterns designed to provide self loading scrapers with good traction in sand and soft, loose materials.

E-3 rock design tires are designed to offer good resistance to rock type damage plus good traction on cranes, hauling trucks and scrapers.

E-4 rock design tires feature tread depths that are 1.5 times deeper than the regular E-3 tread depth tires. This increased tread mass gives extended tread life and exceptional resistance to rock type damage.

E-7 flotation design tires are designed with a shallow rib tread allowing to run in soft, sandy soil. This tire is primarily used on asphalt spreaders.



Titan LCM (E-3) or (E-3/L-3)

- Compact tread design provides resistance to rock damage while still providing excellent traction
- Directional tread design provides excellent traction

Tire Size	Catalog Number	Industry Code	Ply Rating	Rim Width Code	Flange Height Code	Outside Diameter in (mm)	Section Width in (mm)	Section Width Loaded in (mm)	Static Loaded Radius in (mm)	Gross Footprint Area in ² (cm ²)	Tread Depth in (mm)
14.00-24NHS *	6CMR44	E-3	24	10.00W	2.0	54.2 (1377)	15.4 (391)	16.1 (409)	25.3 (643)	180 (1161)	31/32 (24)
14.00-24NHS *	6CLU44	E-3/L-3	28	10.00W	2.0	54.2 (1377)	15.4 (391)	16.1 (409)	25.3 (643)	180 (1161)	31/32 (24)
21.00-25	6CMZ22	E-3	36	15.00	3.0	69.1 (1755)	22.6 (599)	25.0 (635)	31.5 (800)	376 (2425)	43/32 (34)
21.00-25	6CNB22	E-3/L-3	40	15.00	3.0	69.1 (1755)	22.6 (599)	25.0 (635)	31.5 (800)	376 (2425)	43/32 (34)

*Tube Type



Titan ND LCM (E-3) or (E-3/L-3)

Titan MCS (E-3/L-3)

- Non-directional tread design with center riding rib provides excellent all around traction and lateral stability
- Rock service tread design provides resistance to rock damage and long tread life
- MCS – is specifically designed for mobile crane service for use in rough terrain applications
- CRB - Features Aralon Cut Resistant Breaker construction, which provides increased strength and durability without sacrificing heat resistance

Tire Size	Catalog Number	Industry Code	Ply Rating	Rim Width Code	Flange Height Code	Outside Diameter in (mm)	Section Width in (mm)	Section Width Loaded in (mm)	Static Loaded Radius in (mm)	Gross Footprint Area in ² (cm ²)	Tread Depth in (mm)
15.5-25	6NN120	E-3/L-3	12	12.00	1.3	50.3 (1278)	15.5 (394)	17.3 (439)	22.8 (579)	205E (1323)	30/32 (24)
16.00-25	6NDU65	E-3	28	11.25	2.0	59.0 (1499)	17.5 (445)	18.8 (478)	26.8 (681)	204 (1316)	35/32 (28)
18.00-25	6NDW18	E-3	32	13.00	2.5	63.3 (1608)	20.3 (516)	21.3 (541)	29.1 (739)	238 (1536)	39/32 (31)

Titan ND LCM (E-3) or (E-3/L-3) & Titan MCS (E-3/L-3) continued

Tire Size	Catalog Number	Industry Code	Ply Rating	Rim Width Code	Flange Height Code	Outside Diameter in (mm)	Section Width in (mm)	Section Width Loaded in (mm)	Static Loaded Radius in (mm)	Gross Footprint Area in ² (cm ²)	Tread Depth in (mm)
20.5-25	6NN521	E-3/L-3	16	17.00	2.0	58.9 (1496)	21.7 (551)	23.4 (594)	25.5 (648)	315 (2032)	35/32 (28)
20.5-25	6NN921	E-3/L-3	20	17.00	2.0	58.9 (1496)	21.7 (551)	23.4 (594)	25.5 (648)	315 (2032)	35/32 (28)
20.5-25	6NNR21	E-3/L-3	24	17.00	2.0	58.9 (1496)	21.7 (551)	23.4 (594)	25.5 (648)	315 (2032)	35/32 (28)
23.5-25	6NN923	E-3/L-3	20	19.50	2.5	62.0 (1575)	24.7 (627)	25.9 (658)	27.1 (688)	378 (2439)	39/32 (31)
26.5-25	6NN927	E-3/L-3	20	22.00	3.0	67.7 (1720)	27.9 (709)	29.9 (759)	28.3 (719)	466 (3006)	43/32 (34)
26.5-25	6NNT27	E-3/L-3	26	22.00	3.0	67.7 (1720)	27.9 (709)	29.9 (759)	28.3 (719)	466 (3006)	43/32 (34)
26.5-25	6NNW27	E-3/L-3	32	22.00	3.0	67.7 (1720)	27.9 (709)	29.9 (759)	28.3 (719)	466 (3006)	43/32 (34)
26.5-25	6NND27	E-3/L-3	44	22.00	3.0	67.7 (1720)	27.9 (709)	29.9 (759)	28.3 (719)	466 (3006)	43/32 (34)
29.5-25	6NNUW1	E-3/L-3	28	25.00	3.5	74.7 (1897)	30.5 (775)	32.0 (813)	32.2 (819)	656 (4232)	47/32 (37)
29.5-25	6NNXW1	E-3/L-3	34	25.00	3.5	74.7 (1897)	30.5 (775)	32.0 (813)	32.2 (819)	656 (4232)	47/32 (37)
29.5-25	6NNAW1	E-3/L-3	38	25.00	3.5	74.7 (1897)	30.5 (775)	32.0 (813)	32.2 (819)	656 (4232)	47/32 (37)
29.5-29	6NDUW2	E-3	28	25.00	3.5	77.5 (1969)	30.3 (770)	31.7 (805)	34.3 (871)	535 (3452)	47/32 (37)
29.5-29	6NNXW2	E-3/L-3	34	25.00	3.5	77.5 (1969)	30.3 (770)	31.7 (805)	34.3 (871)	535 (3452)	47/32 (37)
29.5-35	6NDXW3	E-3	34	25.00	3.5	83.0 (2108)	30.2 (767)	31.7 (805)	37.7 (958)	472 (3045)	47/32 (37)
CRB											
33.25-35	6NDAW5	E-3	38	27.00	3.5	88.6 (2250)	34.2 (869)	35.8 (909)	38.8 (986)	650 (4194)	53/32 (42)
33.25-35	6NNDW5	E-3/L-3	44	27.00	3.5	88.6 (2250)	34.2 (869)	35.8 (909)	38.8 (986)	650 (4194)	53/32 (42)
33.25-35	6NNKW5	E-3/L-3	56	27.00	3.5	88.6 (2250)	34.2 (869)	35.8 (909)	38.8 (986)	650 (4194)	53/32 (42)
33.5-33	6NDDW6	E-3	44	28.00	4.0	86.9 (2207)	35.1 (892)	35.9 (912)	39.7 (1008)	708 (4568)	53/32 (42)
37.5-33	6NNMW8	E-3/L-3	54	32.00	4.5	93.7 (2380)E	38.3 (973)E	39.0 (991)E	42.2 (1072)E	718 (4632)E	58/32 (46)
MCS											
20.5-25	6MCR21	E-3/L-3	24	17.00	2.0	58.9 (1496)	21.7 (551)	23.4 (594)	25.5 (648)	315 (2031)	35/32 (28)

E - Estimated



Titan SL 100 (E-3) or (E-3/L-3)

- Center riding rib provides a smooth ride and improved lateral stability
- Non-directional tread design pattern provides excellent all around traction and long wear
- CRB - Features Aralon Cut Resistant Breaker construction, which provides increased strength and durability without sacrificing heat resistance

Tire Size	Catalog Number	Industry Code	Ply Rating	Rim Width Code	Flange Height Code	Outside Diameter in (mm)	Section Width in (mm)	Section Width Loaded in (mm)	Static Loaded Radius in (mm)	Gross Footprint Area in ² (cm ²)	Tread Depth in (mm)
33.25-29	6SLWW4	E-3/L-3	32	26.00 27.00	3.5	80.9 (2055)	34.5 (876)	36.3 (922)	35.8 (909)	644 (4155)	53/32 (42)
33.25-29	6SLAW4	E-3/L-3	38	26.00 27.00	3.5	80.9 (2055)	34.5 (876)	36.3 (922)	35.8 (909)	644 (4155)	53/32 (42)
37.25-35	6SLZW7	E-3	36	29.00	3.5	94.5 (2400)	37.2 (945)	39.6 (1006)	42.0 (1067)	864 (5575)	58/32 (46)

Bias Earthmoving



Titan MXL (E-3/L-3)

- Aggressive tread for optimal traction
- Sturdy tread elements for maximum torque transmission

Tire Size	Catalog Number	Industry Code	Ply Rating	Rim Width Code	Flange Height Code	Outside Diameter in (mm)	Section Width in (mm)	Section Width Loaded in (mm)	Section Width Static Loaded Radius in (mm)	Gross Footprint Area in ² (cm ²)	Tread Depth in (mm)
17.5-25	43B117	E-3/L-3	12	14.00	1.5	53.9E (1369)	17.7E (450)	----	24.0E (610)	----	39/32 (31)
20.5-25	43B921	E-3/L-3	20	17.00	2.0	59.4 (1507)	21.8 (554)	----	26.3 (668)	302 (1948)	48/32 (38)
23.5-25	43B123	E-3/L-3	12	19.50	2.5	64.0E (1626)	25.0E (635)	----	28.5E (724)	----	51/32 (41)
23.5-25	43B523	E-3/L-3	16	19.50	2.5	64.0E (1626)	25.0E (635)	----	28.5E (724)	----	51/32 (41)

E - Estimated



Titan Super Rigger (E-3/L-3)

- Non-directional wide tread
- Long wearing tread compound for demanding material handling operations

Tire Size	Catalog Number	Industry Code	Ply Rating	Rim Width Code	Flange Height Code	Outside Diameter in (mm)	Section Width in (mm)	Section Width Loaded in (mm)	Section Width Static Loaded Radius in (mm)	Gross Footprint Area in ² (cm ²)	Tread Depth in (mm)
13.00-24TG	49L333	E-3/L-3	12	9.00GR	---	50.4 (1279)	14.7 (373)	---	23.1 (587)	152 (980)	31/32 (25)
13.00-24TG	49L38A	E-3/L-3	16	10.00VA	---	50.4 (1279)	14.7 (373)	---	23.1 (587)	152 (980)	31/32 (25)
14.00-24TG	49L344	E-3/L-3	12	9.00GR	---	52.6 (1336)	15.3 (389)	16.8 (427)	24.2 (615)	175 (1129)	32/32 (25)
14.00-24TG	49L3R4	E-3/L-3	16	10.00VA	---	52.6 (1336)	15.3 (389)	16.8 (427)	24.2 (615)	175 (1129)	32/32 (25)
14.00-25NHS	49LB65	E-3/L-3	28	10.00	1.5	53.4 (1356)	15.2 (386)	16.3 (414)	24.5 (622)	229 (1477)	32/32 (25)



Titan CM100 (E-3)

- Rock service tread designed for the challenges of large equipment demands
- Solid centerline tread pattern provides excellent cut resistance, smooth ride and extended wear

Tire Size	Catalog Number	Industry Code	Ply Rating	Rim Width Code	Flange Height Code	Outside Diameter in (mm)	Section Width in (mm)	Section Width Loaded in (mm)	Section Width Static Loaded Radius in (mm)	Gross Footprint Area in ² (cm ²)	Tread Depth in (mm)
27.00-49	6M1F79	E-3	48	19.50	4.0	104.6 (2657)	29.7 (754)	32.0 (813)	47.9 (1217)	656 (4232)	53/32 (42)
37.5-39	6M1HW9	E-3	52	32.00	4.5	98.2 (2494)	38.9 (988)	41.0 (1041)	44.9 (1140)	795 (5129)	66/32 (52)



Titan XG-3 (E-3)

- All purpose design for traction and flotation
- Solid centerline provides excellent lateral stability
- CRB - Features Aralon Cut Resistant Breaker construction, which provides increased strength and durability without sacrificing heat resistance

Tire Size	Catalog Number	Industry Code	Ply Rating	Rim Width Code	Flange Height Code	Outside Diameter in (mm)	Section Width in (mm)	Section Width Loaded in (mm)	Static Loaded Radius in (mm)	Gross Footprint Area in ² (cm ²)	Tread Depth in (mm)
37.25-35	6X3ZW7	E-3	36	29.00	3.5	94.6 (2403)	37.6 (955)	39.8 (1011)	41.9 (1064)	802 (5175)	58/32 (46)



Titan Super LCM (E-4)

- Increased tread depth provides extended tread life and exceptional resistance to rock type damage
- Directional tread design provides excellent traction

Tire Size	Catalog Number	Industry Code	Ply Rating	Rim Width Code	Flange Height Code	Outside Diameter in (mm)	Section Width in (mm)	Section Width Loaded in (mm)	Static Loaded Radius in (mm)	Gross Footprint Area in ² (cm ²)	Tread Depth in (mm)
14.00-24NHS *	6LC944	E-4	20	10.00	2.0	54.0 (1372)	15.4 (391)	16.2 (411)	26.1 (663)	174 (1123)	55/32 (44)
14.00-25NHS *	6LC960	E-4	20	10.00	1.5	55.7 (1415)	15.3 (389)	16.2 (411)	25.8 (655)	174 (1123)	55/32 (44)
16.00-25	6LCU65	E-4	28	11.25	2.0	59.6 (1514)	17.5 (445)	18.5 (470)	27.6 (701)	204 (1316)	52/32 (41)
18.00-49	6LCW89	E-4	32	13.00	2.75	89.1 (2263)	19.3 (490)	21.2 (538)	41.2 (1046)	293 (1990)	66/32 (52)

*Tube Type



Titan ND Super LCM (E-4) or (E-4/L-4)

- Non-directional tread design with center riding rib provides excellent all around traction and lateral stability
- Increased tread depth provides extended tread life and exceptional resistance to rock type damage

Tire Size	Catalog Number	Industry Code	Ply Rating	Rim Width Code	Flange Height Code	Outside Diameter in (mm)	Section Width in (mm)	Section Width Loaded in (mm)	Static Loaded Radius in (mm)	Gross Footprint Area in ² (cm ²)	Tread Depth in (mm)
18.00-25	6U4W18	E-4	32	13.00	2.5	64.7 (1643)	20.0 (508)	21.7 (551)	28.9 (734)	246 (1587)	66/32 (52)
18.00-25	6UNB18	E-4/L-4	40	13.00	2.5	64.7 (1643)	20.0 (508)	21.7 (551)	28.9 (734)	246 (1587)	66/32 (52)
18.00-33	6U4W83	E-4	32	13.00	2.5	73.0 (1854)	20.0 (508)	21.3 (541)	32.8 (833)	289 (1865)	66/32 (52)
21.00-49	6U4Z24	E-4	36	15.00	3.0	94.4 (2398)	22.8 (579)	24.3 (617)	43.7 (1110)	442 (2952)	66/32 (52)
21.00-49	6U5C24	E-4/L-4	42	15.00	3.0	95.0 (2413)	22.6 (574)	24.2 (615)	44.2 (1123)	455 (2936)	66/32 (52)

Bias Earthmoving



Titan CM 150 (E-4)

- Deep, non-directional tread provides excellent rock type damage resistance and long tread life
- Solid centerline tread pattern provides smooth ride and excellent lateral traction on high tonnage vehicles
- CRB - Features Aralon Cut Resistant Breaker construction, which provides increased strength and durability without sacrificing heat resistance

Tire Size	Catalog Number	Industry Code	Ply Rating	Rim Width Code	Flange Height Code	Outside Diameter in (mm)	Section Width in (mm)	Section Width Loaded in (mm)	Static Loaded Radius in (mm)	Gross Footprint Area in ² (cm ²)	Tread Depth in (mm)
18.00-33	6M5W83	E-4	32	13.00	2.5	73.8 (1875)	20.4 (518)	21.5 (546)	34.9 (886)	314 (2000)	71/32 (56)
21.00-35	6M5Z25	E-4	36	15.00	3.0	81.0 (2057)	23.5 (597)	24.8 (630)	37.4 (950)	400 (2581)	71/32 (56)
24.00-35	6M5C43	E-4	42	17.00	3.5	81.1 (2060)	23.6 (599)	27.8 (706)	39.6 (1005)	428 (2761)	70/32 (56)
24.00-35	6M5F43	E-4	48	17.00	3.5	81.1 (2060)	23.6 (599)	27.8 (706)	39.6 (1005)	428 (2761)	70/32 (56)
24.00-49	6M5F49	E-4	48	17.00	3.5	100.8 (2560)	26.5 (673)	28.0 (711)	46.9 (1191)	532 (3432)	70/32 (56)
27.00-49	6M5F79	E-4	48	19.50	4.0	106.5 (2705)	30.3 (769)	32.0 (812)	49.3 (1252)	683 (4407)	78/32 (62)
30.00-51	6M5H30	E-4	52	22.00	4.5	114.4 (2906)	32.5 (825)	34.8 (883)	52.7 (1399)	816 (5265)	85/32 (68)
33.00-51	6M5J35	E-4	58	24.00	5.0	119.1 (3025)	35.9 (912)	38.2 (970)	54.7 (1389)	1053 (6794)	98/32 (78)
33.25-35	6M5AW5	E-4	38	27.00	3.5	89.3 (2268)	34.2 (868)	36.6 (929)	39.8 (1011)	700 (4516)	78/32 (62)
33.25-35	6M5DW5	E-4	44	27.00	3.5	89.3 (2268)	34.2 (868)	36.6 (929)	39.8 (1011)	700 (4516)	78/32 (62)
37.25-35	6M5ZW7	E-4	36	31.00	3.5	94.3 (2395)	36.1 (916)	38.3 (972)	42.0 (1067)	905 (5839)	87/32 (69)



Titan Quarry Special CM 150 (E-4) or (E-4/L-4)

- Special tread compound with excellent chip and cut resistance from shot rock
- Tread designed for traction with deep lugs and center riding rib for smoother ride
- CRB - Features Aralon Cut Resistant Breaker construction, which provides increased strength and durability without sacrificing heat resistance

Tire Size	Catalog Number	Industry Code	Ply Rating	Rim Width Code	Flange Height Code	Outside Diameter in (mm)	Section Width in (mm)	Section Width Loaded in (mm)	Static Loaded Radius in (mm)	Gross Footprint Area in ² (cm ²)	Tread Depth in (mm)
18.00-33	6QSW83	E-4	32	13.00	2.5	73.8 (1875)	20.4 (518)	21.5 (546)	34.9 (886)	314 (2000)	71/32 (56)
21.00-35	6QSZ25	E-4	36	15.00	3.0	81.0 (2057)	23.5 (597)	24.8 (630)	37.4 (950)	400 (2581)	71/32 (56)
21.00-35	6QSC25	E-4/L-4	42	15.00	3.0	81.0 (2057)	23.5 (597)	24.8 (630)	37.4 (950)	400 (2581)	71/32 (56)
24.00-35	6QSC43	E-4	42	17.00	3.5	81.1 (2060)	23.6 (599)	27.8 (706)	39.6 (1005)	428 (2761)	70/32 (56)
24.00-35	6QSF43	E-4	48	17.00	3.5	81.1 (2060)	23.6 (599)	27.8 (706)	39.6 (1005)	428 (2761)	70/32 (56)
24.00-49	6QSF49	E-4	48	17.00	3.5	100.8 (2560)	26.5 (673)	28.0 (711)	46.9 (1191)	532 (3432)	70/32 (56)
27.00-49	6QSF79	E-4/L-4	48	19.50	4.0	106.5 (2705)	30.3 (769)	32.0 (812)	49.3 (1252)	683 (4407)	78/32 (62)
30.00-51	6QSH30	E-4	52	22.00	4.5	114.4 (2906)	32.5 (826)	34.8 (884)	52.7 (1339)	816 (5265)	85/32 (67)
33.00-51	6QSJ35	E-4	58	24.00	5.0	119.1 (3025)	35.9 (912)	38.2 (970)	54.7 (1389)	1053 (6794)	98/32 (78)

Bias Earthmoving



Titan CH 150 (E-4/L-4)

- Deep, non-directional tread provides excellent rock type damage resistance and long tread life
- Solid centerline tread pattern provides smooth ride and excellent lateral traction

Tire Size	Catalog Number	Industry Code	Ply Rating	Rim Width Code	Flange Height Code	Outside Diameter in (mm)	Section Width in (mm)	Section Width Loaded in (mm)	Static Loaded Radius in (mm)	Gross Footprint Area in ² (cm ²)	Tread Depth in (mm)
18.00-25	6HLB18	E-4/L-4	40	13.00	2.5	65.1 (1654)	20.4 (518)	21.2 (538)	30.4 (772)	280 (1806)	66/32 (52)



Tread A



Tread B

Titan Super Sand Flotation (E-7)

- Rib design provides excellent steering stability and improved lateral traction
- Shallow tread depth provides excellent heat dissipation
- Designed for paving applications

Tire Size	Tread Style	Catalog Number	Industry Code	Ply Rating	Rim Width Code	Flange Height Code	Outside Diameter in (mm)	Section Width in (mm)	Section Width Loaded in (mm)	Static Loaded Radius in (mm)	Gross Footprint Area in ² (cm ²)	Tread Depth in (mm)
14.00-20DT	A	SSF0D4	E-7	10	10.00W	1.8	47.8 (1219)	15.6 (384)	17.0 (432)	20.8 (503)	166 (1523)	12/32 (10)
16.00-24DT	A	6DT1D6	E-7	12	10.00W	2.0	57.1 (1450)	18.7 (475)	20.5 (516)	24.4 (620)	393 (2536)	14/32 (11)
18.00-25DT	B	6DT5D8	E-7	16	10.00	1.5	59.2 (1504)	19.8 (503)	23.1 (587)	24.2 (615)	306 (1974)	15/32 (12)
18.00-25DT	B	6DT9D8	E-7	20	10.00	1.5	59.2 (1504)	19.8 (503)	23.1 (587)	24.2 (615)	306 (1974)	15/32 (12)
21.00-25DT	B	6DTUK2	E-7	28	15.00	3.0	66.7 (1693)	23.1 (587)	24.9 (631)	28.5 (723)	423 (2729)	32/32 (25)

Bias Grader Service

Grader Service Tires

The “G” series type tires are used primarily on motor graders in all types of applications. These tires are designed for speeds up to 25 mph and unlimited distance. G-2 traction design tires have open tread patterns designed to provide good traction.



Titan Loader Grader III (G-2) or (L-2/G-2)

- Interlocking center lugs provide excellent steering stability in soft ground
- Open shoulders provide excellent traction and self-cleaning

Tire Size	Catalog Number	Industry Code	Ply Rating	Rim Width Code	Flange Height Code	Outside Diameter in (mm)	Section Width in (mm)	Section Width Loaded in (mm)	Static Loaded Radius in (mm)	Gross Footprint Area in ² (cm ²)	Tread Depth in (mm)
13.00-24TG	LG3333	G-2	12	8.00TG	---	51.0 (1295)	14.1 (358)	15.2 (386)	23.4 (594)	175 (1129)	29/32 (23)
14.00-24TG	LG3344	G-2	12	8.00TG	---	53.6 (1361)	14.4 (366)	16.1 (409)	24.0 (609)	190 (1226)	31/32 (25)
15.5-25	LG3120	L-2/G-2	12	12.00	1.3	50.0 (1270)	15.4 (394)	16.2 (413)	22.6 (573)	160 (1032)	30/32 (24)
17.5-25	LG3117	L-2/G-2	12	14.00	1.5	52.8 (1341)	17.3 (438)	18.3 (409)	23.6 (599)	203 (1290)	32/32 (25)
17.5-25	LG3517	L-2/G-2	16	14.00	1.5	52.8 (1341)	17.3 (438)	18.3 (409)	23.6 (599)	203 (1290)	32/32 (25)
17.5-25	LG3917	L-2/G-2	20	14.00	1.5	52.8 (1341)	17.3 (438)	18.3 (409)	23.6 (599)	203 (1290)	32/32 (25)



Titan Motor Grader HD (L-2/G-2)

- Proven performance tread design with massive lugs and large center overlap to resist buckling, tearing and cracking
- Very durable and resistant to punctures, features a heavy duty tubeless construction

Tire Size	Catalog Number	Industry Code	Ply Rating	Rim Width Code	Flange Height Code	Outside Diameter in (mm)	Section Width in (mm)	Section Width Loaded in (mm)	Static Loaded Radius in (mm)	Gross Footprint Area in ² (cm ²)	Tread Depth in (mm)
13.00-24TG	367333	L-2/G-2	12	8.00TG	---	50.5 (1283)	14.8 (376)	16.8 (427)	24.2 (614)	175 (1129)	29/32 (23)
13.00-24TG	36738A	L-2/G-2	16	8.00TG	---	51.4 (1306)	14.0 (356)	---	23.1 (587)	171 (1101)	29/32 (23)
14.00-24TG	367344	L-2/G-2	12	10.00VA	---	54.3 (1378)	15.2 (386)	---	24.0 (610)	179 (1155)	31/32 (25)
14.00-24TG	3673R7	L-2/G-2	14	10.00VA	---	53.0 (1346)	15.1 (384)	---	24.0 (610)	---	31/32 (25)



Titan Super Grader (G-2/L-2)

- Directional, open tread design is self cleaning, providing excellent traction

Tire Size	Catalog Number	Industry Code	Ply Rating	Rim Width Code	Flange Height Code	Outside Diameter in (mm)	Section Width in (mm)	Section Width Loaded in (mm)	Static Loaded Radius in (mm)	Gross Footprint Area in ² (cm ²)	Tread Depth in (mm)
16.00-24TG	3SG666	L-2/G-2	16	10.00VA	---	58.8 (1494)	17.5 (445)	---	26.1 (663)	255 (1645)	35/32 (28)



Titan HD 2000II (G-2)

- Deeper non-skid depth guards against punctures and premature wearouts
- Six layer high tensile nylon construction creates one of the strongest tires in the industry
- Massive rim guard reduces damage
- Design ensures compatibility with steel

Tire Size	Catalog Number	Industry Code	Ply Rating	Rim Width Code	Flange Height Code	Outside Diameter in (mm)	Section Width in (mm)	Section Width Loaded in (mm)	Static Loaded Radius in (mm)	Gross Footprint Area in ² (cm ²)	Tread Depth in (mm)
13.00-24TG	49E333	G-2	12	9.00GR	---	50.6 (1285)	13.8 (351)	---	23.0 (584)	---	32/32 (25)
13.00-24TG	49E38A	G-2	16	9.00GR	---	50.6 (1285)	13.8 (351)	---	23.0 (584)	---	32/32 (25)
14.00-24TG	49E344	G-2	12	9.00GR	---	52.4 (1331)	14.9 (378)	---	24.5 (622)	---	38/32 (30)

Bias Loader - Dozer Service

Loader - Dozer Service Tires

The “L” series type tires are used on all size loaders and dozers in off-the-road applications. Most loader type tires, because of their extremely heavy construction, are limited to very low speeds, less than 5 mph, and very short distances, less than 250 feet.

L-2 traction design tires have open tread patterns designed to provide good traction in sand and soft, loose materials.

L-3 rock design tires are designed to offer good resistance to rock type damage plus good traction in general purpose loader operations.

L-4 rock design tires feature tread depths that are 1.5 times deeper than the regular L-3 tread depth tires. This increased tread mass gives extended tread life and exceptional resistance to rock type damage.

L-5 rock design tires feature tread depths that are 2.5 times deeper than the regular L-3 tread depth tires. This extremely heavy tread mass offers improved rock resistance and extended tread life in severe rock conditions.

L-5S solid design tires offer a massive tread for the ultimate in resisting rock damage and penetration. This tire is perfect for those applications where shoulder lug tearing has been a problem in the past or where protective chains are required.

L-5/L-5S is unique in that it offers both rock design pattern along with a smooth tread design. This design with the smooth design mounted on the outboard side of the loader provides exceptional tearing and cut resistance while providing additional traction.



Titan Loader Dozer II (L-2)

- Exceptional performance rating and heavy duty ply ratings
- Laterally designed lugs provide maximum, even traction along the length of the lug
- Lugs resist buckling, cracking and tearing

Tire Size	Catalog Number	Industry Code	Ply Rating	Rim Width Code	Flange Height Code	Outside Diameter in (mm)	Section Width in (mm)	Section Width Loaded in (mm)	Static Loaded Radius in (mm)	Gross Footprint Area in ² (cm ²)	Tread Depth in (mm)
15.5-25	431120	L-2	12	12.00	1.3	49.9 (1267)	15.8 (401)	---	22.5 (572)	---	29/32 (23)
17.5-25	431117	L-2	12	14.00	1.5	52.1 (1323)	17.8 (452)	18.9 (480)	23.1 (587)	276 (1781)	32/32 (25)
17.5-25	431517	L-2	16	14.00	1.5	51.7 (1313)	18.1 (460)	---	23.9 (606)	276 (1781)	32/32 (25)
20.5-25	431121	L-2	12	17.00	2.0	56.8 (1443)	20.9 (531)	24.8 (629)	24.4 (620)	371 (2394)	36/32 (29)
20.5-25	431521	L-2	16	17.00	2.0	57.9 (1471)	21.1 (536)	---	25.0 (635)	353 (2277)	36/32 (29)
20.5-25	431921	L-2	20	17.00	2.0	58.1 (1476)	21.2 (538)	---	25.0 (635)	381 (2458)	36/32 (29)
23.5-25	431123	L-2	12	19.50	2.5	62.5 (1588)	24.4 (620)	---	28.5 (724)	423 (2730)	38/32 (30)
23.5-25	431523	L-2	16	19.50	2.5	62.5 (1588)	24.4 (620)	---	28.5 (724)	467 (3013)	38/32 (30)
23.5-25	431923	L-2	20	19.50	2.5	63.7 (1618)	23.7 (602)	---	28.5 (724)	426 (2748)	38/32 (30)



Titan Lift Rigger II (L-2)

- Combines thicker, self-cleaning lugs in a directional pattern with a low aspect ratio
- Greater lateral stability and flotation than conventional aerial lift tires

Tire Size	Catalog Number	Industry Code	Ply Rating	Rim Width Code	Flange Height Code	Outside Diameter in (mm)	Section Width in (mm)	Section Width Loaded in (mm)	Static Loaded Radius in (mm)	Gross Footprint Area in ² (cm ²)	Tread Depth in (mm)
400/70-20	43C34L	L-2	150 A8/B	14.00	61 (4.2)	25 (40)	7,150 (3245)	42.9 (1090)	15.9 (404)	19.3 (490)	33/32 (26)
LSW 400-648	G3C34L	L-2	149 A8/B	356LSW	58 (4.0)	25 (40)	7,150 (3245)	42.9 (1090)	15.7 (399)	19.3 (490)	33/32 (26)

Bias Loader - Dozer Service



Titan Loader Grader III (L-2/G-2)

- Interlocking center lugs provide excellent steering stability in soft ground
- Open shoulders provide excellent traction and self-cleaning

Tire Size	Catalog Number	Industry Code	Ply Rating	Rim Width Code	Flange Height Code	Outside Diameter in (mm)	Section Width in (mm)	Section Width Loaded in (mm)	Static Loaded Radius in (mm)	Gross Footprint Area in ² (cm ²)	Tread Depth in (mm)
15.5-25	LG3120	L-2/G-2	12	12.00	1.3	50.0 (1270)	15.4 (394)	16.2 (413)	22.6 (573)	160 (1032)	30/32 (24)
17.5-25	LG3117	L-2/G-2	12	14.00	1.5	52.8 (1341)	17.3 (438)	18.3 (409)	23.6 (599)	203 (1290)	32/32 (25)
17.5-25	LG3517	L-2/G-2	12	14.00	1.5	52.8 (1341)	17.3 (438)	18.3 (409)	23.6 (599)	203 (1290)	32/32 (25)
17.5-25	LG3917	L-2/G-2	12	14.00	1.5	52.8 (1341)	17.3 (438)	18.3 (409)	23.6 (599)	203 (1290)	32/32 (25)



Titan Motor Grader HD (L-2/G-2)

- Proven performance tread design with massive lugs and large center overlap to resist buckling, tearing, and cracking
- Very durable and resistant to punctures, features a heavy duty tubeless construction

Tire Size	Catalog Number	Industry Code	Ply Rating	Rim Width Code	Flange Height Code	Outside Diameter in (mm)	Section Width in (mm)	Section Width Loaded in (mm)	Static Loaded Radius in (mm)	Gross Footprint Area in ² (cm ²)	Tread Depth in (mm)
13.00-24TG	367333	L-2/G-2	12	8.00TG	---	50.5 (1283)	14.8 (376)	16.8 (427)	24.2 (614)	175 (1129)	29/32 (23)
13.00-24TG	36738A	L-2/G-2	16	8.00TG	---	51.4 (1306)	14.0 (356)	---	23.1 (587)	171 (1101)	29/32 (23)
14.00-24TG	367344	L-2/G-2	12	10.00VA	---	54.3 (1378)	15.2 (386)	---	24.0 (610)	179 (1155)	31/32 (25)
14.00-24TG	3673R7	L-2/G-2	14	10.00VA	---	53.0 (1346)	15.1 (384)	---	24.0 (610)	---	31/32 (25)



Titan Super Grader (L-2/G-2)

- Directional, open tread design is self cleaning, providing excellent traction

Tire Size	Catalog Number	Industry Code	Ply Rating	Rim Width Code	Flange Height Code	Outside Diameter in (mm)	Section Width in (mm)	Section Width Loaded in (mm)	Static Loaded Radius in (mm)	Gross Footprint Area in ² (cm ²)	Tread Depth in (mm)
16.00-24TG	367333	L-2/G-2	16	10.00VA	---	58.8 (1494)	17.5 (445)	---	26.1 (663)	255 (1645)	35/32 (28)

Bias Loader - Dozer Service



Titan Super Rigger (L-3/E-3)

- Non-directional wide tread
- Long wearing tread compound for demanding material handling operations

Tire Size	Catalog Number	Industry Code	Ply Rating	Rim Width Code	Flange Height Code	Outside Diameter in (mm)	Section Width in (mm)	Section Width Loaded in (mm)	Static Loaded Radius in (mm)	Gross Footprint Area in ² (cm ²)	Tread Depth in (mm)
13.00-24TG	49L333	L-3/E-3	12	9.00GR	---	50.5 (1283)	14.8 (376)	---	22.3 (566)	193 (1245)	31/32 (25)
13.00-24TG	49L38A	L-3/E-3	16	10.00VA	---	50.8 (1290)	13.4 (340)	---	23.3 (592)	---	31/32 (25)
14.00-24TG	49L344	L-3/E-3	12	9.00GR	---	52.6 (1336)	15.3 (389)	16.8 (427)	23.5 (596)	234 (5944)	32/32 (25)
14.00-24TG	49L3R4	L-3/E-3	16	10.00VA	---	53.7 (1364)	15.3 (389)	---	23.8 (605)	---	32/32 (25)
14.00-25NHS	49LB65	L-3/E-3	28	10.00	1.5	53.4 (1356)	15.2 (386)	16.3 (414)	24.5 (622)	229 (1477)	32/32 (25)



Titan ND LCM (L-3) or (L-3/E-3) Titan MCS LCM (L-3/E-3)

- Non-directional tread design with center riding rib provides excellent all around traction and lateral stability
- Rock service tread design provides long tread life and resistance to rock damage
- MCS – is specifically designed for mobile crane service for use in rough terrain applications
- CRB - Features Aralon Cut Resistant Breaker construction, which provides increased strength and durability without sacrificing heat resistance

Tire Size	Catalog Number	Industry Code	Ply Rating	Rim Width Code	Flange Height Code	Outside Diameter in (mm)	Section Width in (mm)	Section Width Loaded in (mm)	Static Loaded Radius in (mm)	Gross Footprint Area in ² (cm ²)	Tread Depth in (mm)
15.5-25	6NN120	L-3/E-3	12	12.00	1.3	50.3 (1278)	15.5 (394)	17.3 (494)	22.8 (579)	205E (1323)	30/32 (24)
16.00-25	6N3W65	L-3	32	11.25	2.0	59.0 (1499)	17.5 (445)	18.8 (478)	26.8 (681)	204 (1316)	35/32 (28)
17.5-25	6N3117	L-3	12	14.00	1.5	53.7 (1364)	17.5 (445)	19.2 (488)	23.5 (597)	264 (1703)	30/32 (24)
17.5-25	6N3517	L-3	16	14.00	1.5	53.7 (1364)	17.5 (445)	19.2 (488)	23.5 (597)	264 (1703)	30/32 (24)
17.5-25	6N3R17	L-3	24	14.00	1.5	53.7 (1364)	17.5 (445)	19.2 (488)	23.5 (597)	264 (1703)	30/32 (24)
20.5-25	6NN521	L-3/E-3	16	17.00	2.0	59.3 (1506)	20.9 (531)	21.9 (556)	26.5 (673)	315 (2032)	35/32 (28)
20.5-25	6NN921	L-3/E-3	20	17.00	2.0	59.3 (1506)	20.9 (531)	21.9 (556)	26.5 (673)	315 (2032)	35/32 (28)
20.5-25	6NNR21	L-3/E-3	24	17.00	2.0	59.3 (1506)	20.9 (531)	21.9 (556)	26.5 (673)	315 (2032)	35/32 (28)
23.5-25	6NN923	L-3/E-3	20	19.50	2.5	62.9 (1598)	25.0 (635)	25.5 (648)	27.6 (701)	378 (2439)	39/32 (31)
26.5-25	6NN927	L-3/E-3	20	22.00	3.0	67.7 (2634)	27.8 (706)	29.4 (747)	28.9 (734)	490 (3161)	43/32 (34)
26.5-25	6NNT27	L-3/E-3	26	22.0	3.0	67.7 (2634)	27.8 (706)	29.4 (747)	28.9 (734)	490 (3161)	43/32 (34)
26.5-25	6NNW27	L-3/E-3	32	22.0	3.0	67.7 (2634)	27.8 (706)	29.4 (747)	28.9 (734)	490 (3161)	43/32 (34)
26.5-25	6NND27	L-3/E-3	44	22.00	3.0	67.7 (2634)	27.8 (706)	29.4 (747)	28.9 (734)	490 (3161)	43/32 (34)
29.5-25	6NNUW1	L-3/E-3	28	25.00	3.0	74.1 (1877)	31.0 (787)	33.4 (848)	31.5 (800)	648 (4181)	47/32 (37)
29.5-25	6NNXW1	L-3/E-3	34	25.00	3.0	74.1 (1877)	31.0 (787)	33.4 (848)	31.5 (800)	648 (4181)	47/32 (37)
29.5-25	6NNAW1	L-3/E-3	38	25.00	3.0	74.1 (1877)	31.0 (787)	33.4 (848)	31.5 (800)	648 (4181)	47/32 (37)
29.5-29	6NNXW2	L-3/E-3	34	25.00	3.5	73.4 (1864)	30.5 (775)	32.0 (813)	31.8 (808)	571 (3684)	47/32 (37)
29.5-35	6N3XW3	L-3	34	25.00	3.5	83.0 (2108)	30.2 (767)	31.7 (805)	37.7 (958)	472 (3045)	47/32 (37)
CRB 33.25-35	6NNDW5	L-3/E-3	44	27.00	3.5	88.6 (2250)	34.2 (869)	35.8 (909)	38.8 (986)	650 (4194)	53/32 (42)
33.25-35	6NNKW5	L-3/E-3	56	27.00	3.5	88.6 (2250)	34.2 (869)	35.8 (909)	38.8 (986)	650 (4194)	53/32 (42)
37.5-33	6NNMW8	L-3/E-3	54	32.00	4.5	93.7 (2380)	38.3E (973)	39.0E (991)	42.2E (1072)	718E (4632)	58/32 (46)
MCS 20.5-25	6MCR21	L-3/E-3	24	17.00	2.0	58.9 (1496)	21.7 (551)	23.4 (594)	25.5 (648)	315 (2031)	35/32 (28)

E - Estimated

Bias Loader - Dozer Service



Titan LD 100 (L-3)

- Solid centerline tread pattern provides excellent cut resistance, smooth ride and extended wear
- Non-directional tread design provides excellent all around traction and long wear
- CRB - Features Aralon Cut Resistant Breaker construction, which provides increased strength and durability without sacrificing heat resistance

Tire Size	Catalog Number	Industry Code	Ply Rating	Rim Width Code	Flange Height Code	Outside Diameter in (mm)	Section Width in (mm)	Section Width Loaded in (mm)	Static Loaded Radius in (mm)	Gross Footprint Area in ² (cm ²)	Tread Depth in (mm)
20.5-25	6D1921	L-3	20	17.00	2.0	58.7 (1491)	21.6 (549)	23.3 (592)	25.8 (655)	345 (2225)	40/32 (32)
23.5-25	6D1923	L-3	20	19.50	2.5	62.9 (1598)	25.5 (648)	26.7 (678)	27.6 (701)	399 (2574)	43/32 (34)
26.5-25	6D1927	L-3	20	22.00	3.0	67.9 (1725)	28.7 (729)	30.6 (777)	29.7 (754)	513 (3310)	49/32 (39)
29.5-25	6D1UW1	L-3	28	25.00	3.5	73.7 (1872)	31.1 (790)	33.5 (851)	31.9 (810)	633 (4084)	56/32 (45)
29.5-25	6D1XW1	L-3	34	25.00	3.5	73.7 (1872)	31.1 (790)	33.5 (851)	31.9 (810)	633 (4084)	56/32 (45)



Titan SL 100 (L-3/E-3)

- Center riding rib provides a smooth ride and improved lateral stability
- Non-directional tread design provides excellent all around traction and long wear
- CRB - Features Aralon Cut Resistant Breaker construction, which provides increased strength and durability without sacrificing heat resistance

Tire Size	Catalog Number	Industry Code	Ply Rating	Rim Width Code	Flange Height Code	Outside Diameter in (mm)	Section Width in (mm)	Section Width Loaded in (mm)	Static Loaded Radius in (mm)	Gross Footprint Area in ² (cm ²)	Tread Depth in (mm)
33.25-29	6SLWW4	L-3/E-3	32	27.00	3.5	80.9 (2055)	34.5 (876)	36.3 (922)	35.8 (909)	644 (4155)	53/32 (42)
33.25-29	6SLAW4	L-3/E-3	38	27.00	3.5	80.9 (2055)	34.5 (876)	36.3 (922)	35.8 (909)	644 (4155)	53/32 (42)



Titan MXL (L-3/E-3)

- Multiple nylon body ply construction for improved penetration resistance
- Large contact area for improved tread wear
- Lug design offers increased biting edges

Tire Size	Catalog Number	Industry Code	Ply Rating	Rim Width Code	Flange Height Code	Outside Diameter in (mm)	Section Width in (mm)	Section Width Loaded in (mm)	Static Loaded Radius in (mm)	Gross Footprint Area in ² (cm ²)	Tread Depth in (mm)
17.5-25	43B117	L-3/E-3	12	14.00	1.5	53.9E (1369)	17.7E (450)	---	24.0E (610)	---	39/32 (31)
20.5-25	43B921	L-3/E-3	20	17.00	2.0	59.4 (1507)	21.8 (554)	---	26.3 (668)	302 (1948)	48/32 (38)
23.5-25	43B123	L-3/E-3	12	19.50	2.5	64.0E (1626)	25.0E (635)	---	28.5E (724)	---	51/32 (41)
23.5-25	43B523	L-3/E-3	16	19.50	2.5	64.0E (1626)	25.0E (635)	---	28.5E (724)	---	51/32 (41)

Bias Loader - Dozer Service



Titan Super LCM (L-4)

- Deep tread depth and interlocking tread pattern provide long tread life plus exceptional traction

Tire Size	Catalog Number	Industry Code	Ply Rating	Rim Width Code	Flange Height Code	Outside Diameter in (mm)	Section Width in (mm)	Section Width Loaded in (mm)	Static Loaded Radius in (mm)	Gross Footprint Area in ² (cm ²)	Tread Depth in (mm)
16.00-25	6L4W65	L-4	32	11.25	2.0	59.6 (1514)	17.5 (445)	18.5 (470)	27.6 (701)	204 (1316)	52/32 (41)



Titan LD 150 (L-4)

- Deep tread provides excellent rock type damage resistance and long tread life
- Non-directional, solid centerline tread pattern provides excellent cut resistance, smooth ride and extended wear
- CRB - Features Aralon Cut Resistant Breaker construction, which provides increased strength and durability without sacrificing heat resistance
- Belted 7x7 - Features 7x7 steel belted construction which provides increased cut resistance and extended wear

Tire Size	Catalog Number	Industry Code	Ply Rating	Rim Width Code	Flange Height Code	Outside Diameter in (mm)	Section Width in (mm)	Section Width Loaded in (mm)	Static Loaded Radius in (mm)	Gross Footprint Area in ² (cm ²)	Tread Depth in (mm)
23.5-25	6DE923	L-4	20	19.50	2.5	67.1 (1704)	25.1 (638)	26.8 (681)	30.1 (765)	449 (2896)	66/32 (52)
23.5-25	6DER23	L-4	24	19.50	2.5	67.1 (1704)	25.1 (638)	26.8 (681)	30.1 (765)	449 (2896)	66/32 (52)
26.5-25	6DET27	L-4	26	22.00	3.0	70.7 (1796)	27.6 (701)	29.6 (752)	31.5 (800)	509 (3284)	66/32 (52)
29.5-25	6DEUW1	L-4	28	25.00	3.5	75.5 (1918)	30.2 (767)	32.9 (836)	33.0 (838)	599 (3864)	70/32 (56)
29.5-29	6DEUW2	L-4	28	25.00	3.5	78.8 (2002)	30.2 (767)	32.9 (836)	33.0 (838)	599 (3864)	70/32 (56)
35/65-33	6DLC6B	L-4	42	28.00	3.5	81.5 (2070)	35.1 (891)	36.8 (935)	36.6 (930)	658 (4244)	70/32 (56)



Titan CH 150 (L-4/E-4)

- Deep, non-directional tread provides excellent rock type damage resistance and long tread life
- Solid centerline tread pattern provides smooth ride and excellent lateral traction

Tire Size	Catalog Number	Industry Code	Ply Rating	Rim Width Code	Flange Height Code	Outside Diameter in (mm)	Section Width in (mm)	Section Width Loaded in (mm)	Static Loaded Radius in (mm)	Gross Footprint Area in ² (cm ²)	Tread Depth in (mm)
18.00-25	6HLB18	L-4/E-4	40	13.00	2.5	65.1 (1654)	20.4 (518)	21.7 (551)	29.7 (754)	360 (2323)	66/32 (52)

Bias Loader - Dozer Service



Titan CM 150 (L-4)

- Deep tread depth, center running rib and massive lugs provide long tread life and low cost per hour with excellent traction

Tire Size	Catalog Number	Industry Code	Ply Rating	Rim Width Code	Flange Height Code	Outside Diameter in (mm)	Section Width in (mm)	Section Width Loaded in (mm)	Static Loaded Radius in (mm)	Gross Footprint Area in ² (cm ²)	Tread Depth in (mm)
21.00-35	6MLC25	L-4	42	15.00	3.0	81.0 (2057)	23.5 (597)	24.8 (630)	37.4 (950)	400 (2581)	71/32 (56)
30.00-51	6M6H30	L-4	52	22.00	4.5	114.4E (2905)	32.5E (825)	34.8E (883)	52.7E (1399)	816E (5265)	85E/32 (68)

E - Estimated



Titan LS 150 (L-4T)

- Open, deep tread pattern provides excellent traction in extreme conditions
- Tread compound designed for increased resistance to tread chunking and tearing
- Steel belted construction provides excellent penetration resistance
- HD version has twice as many belts

Tire Size	Catalog Number	Industry Code	Ply Rating	Rim Width Code	Flange Height Code	Outside Diameter in (mm)	Section Width in (mm)	Section Width Loaded in (mm)	Static Loaded Radius in (mm)	Gross Footprint Area in ² (cm ²)	Tread Depth in (mm)
725/70-25	LT45M6	L-4T	16	22.00	3.0	65.8 (1672)	26.9 (684)	29.2 (742)	27.8 (707)	608 (3923)	72/32 (57)
725/70-25	LH45M6 (HD)	L-4T	16	22.00	3.0	65.8 (1672)	26.9 (684)	29.2 (742)	27.8 (707)	608 (3923)	72/32 (57)



Titan LD 250 CRB



Titan LD 250 Belted 7x7

Titan LD 250 (L-5) CRB Titan LD 250 Belted (L-5) 7x7

- Extra deep tread provides excellent rock type damage resistance and long tread life
- Open non-directional tread pattern provides all around traction with excellent self-cleaning
- CRB - Features Aralon Cut Resistant Breaker construction, which provides increased strength and durability without sacrificing heat resistance
- Belted 7x7 - Features 7x7 steel belted construction, which provides increased cut resistance and extended wear

Tire Size	Catalog Number	Industry Code	Ply Rating	Rim Width Code	Flange Height Code	Outside Diameter in (mm)	Section Width in (mm)	Section Width Loaded in (mm)	Static Loaded Radius in (mm)	Gross Footprint Area in ² (cm ²)	Tread Depth in (mm)
20.5-25	6DA921	L-5	20	17.00	2.0	61.3 (1557)	21.4 (544)	23.1 (587)	27.7 (704)	294 (1897)	89/32 (71)
23.5-25	6DA923	L-5	20	19.50	2.5	66.4 (1686)	24.9 (632)	26.5 (673)	29.6 (752)	400 (2580)	95/32 (75)
26.5-25	6DAT27	L-5	26	22.00	3.0	71.5 (1816)	28.1 (714)	29.7 (754)	31.9 (810)	490 (3161)	105/32 (83)
29.5-25	6DAUW1	L-5	28	25.00	3.5	75.1 (1908)	30.1 (765)	32.3 (820)	32.9 (836)	673 (4341)	128/32 (102)
29.5-29	6DAUW2	L-5	28	25.00	3.5	79.1 (2009)	30.0 (762)	31.8 (808)	35.5 (902)	669 (4315)	115/32 (91)
29.5-29	6DAXW2	L-5	34	25.00	3.5	79.1 (2009)	30.0 (762)	31.8 (808)	35.5 (902)	669 (4315)	115/32 (91)
37.25-35	6DACW7	L-5	42	31.00	4.0	96.6 (2454)	37.5 (953)	39.9 (1013)	43.7 (1110)	961 (6200)	141/32 (112)
Belted											
35/65-33	6DBC6B	L-5	42	28.00	3.5	81.2 (2085)	33.9 (861)	35.3 (897)	36.8 (935)	722 (4657)	115/32 (91)
40/65-39	6DBV6C	L-5	30	32.00	4.0	93.8 (2383)	39.8 (1011)	41.1 (1044)	42.1 (1069)	963 (6213)	128/32 (102)
45/65-45	6DBJ7E	L-5	58	36.00	4.5	106.9 (2715)	42.4 (1077)	44.9 (1140)	48.1 (1222)	1193 (7695)	140/32 (111)
41.25/70-39	6DBC6D	L-5	42	32.00	4.5	99.1 (2207)	40.2 (1021)	42.7 (1085)	45.2 (1148)	1041 (7614)	140/32 (111)

E - Estimated

Bias Loader - Dozer Service



Titan LD 250 CRB



Titan LD 250 Belted 7x7

Titan LD 250 Haf-Trac (L-5/L-5S) CRB

Titan LD 250 Haf-Trac Belted (L-5/L-5S) 7x7

- Extra deep tread depth provides long tread life in extreme conditions
- Smooth tread used on the outside provides excellent rock type damage resistance, while the pattern on the inside provides increased traction
- CRB - Features Aralon Cut Resistant Breaker construction, which provides increased strength and durability without sacrificing heat resistance
- Belted 7x7 - Features 7x7 steel belted construction, which provides increased cut resistance and extended wear

Tire Size	Catalog Number	Industry Code	Ply Rating	Rim Width Code	Flange Height Code	Outside Diameter in (mm)	Section Width in (mm)	Section Width Loaded in (mm)	Static Loaded Radius in (mm)	Gross Footprint Area in ² (cm ²)	Tread Depth in (mm)
CRB 29.5-29	6HAUW2	L-5L-5S	28	25.00	3.5	78.9 (2004)	30.2 (767)	32.2 (818)	35.0 (889)	608 (3293)	115/32 (91)
Belted 35/65-33	6HBC6B	L-5L-5S	42	28.00	3.5	81.9 (2080)	34.6 (879)	36.1 (916)	36.6 (930)	715 (4611)	115/32 (91)
41.25/70-39	6HBC6D	L-5/L-5S	42	32.00	4.5	99.3 (2522)	41.6 (1057)	43.5 (1105)	45.2 (1148)	1100 (7097)	140/32 (111)
45/65-45	6HBJ7E	L-5L-5S	58	36.00	4.5	107.8 (2738)	42.7 (1085)	44.3 (1125)	48.5 (1232)	1325 (8546)	142/32 (113)



Titan LD250 Super Smooth (L-5S) CRB, CAB, and Belted 7x7

- Extra deep tread depth provides long tread life in extreme conditions
- Smooth tread design provides the maximum rock type damage resistance
- CRB - Features Aralon Cut Resistant Breaker construction, which provides increased strength and durability without sacrificing heat resistance
- CAB - Features Cushion Armor Breaker steel belted construction, which gives increased cut resistance
- Belted 7x7 - Features 7x7 steel belted construction, which provides increased cut resistance and extended wear

Tire Size	Catalog Number	Industry Code	Ply Rating	Rim Width Code	Flange Height Code	Outside Diameter in (mm)	Section Width in (mm)	Section Width Loaded in (mm)	Static Loaded Radius in (mm)	Gross Footprint Area in ² (cm ²)	Tread Depth in (mm)
CRB 20.5-25	6WA921	L-5S	20	17.00	2.0	61.3 (1557)	21.4 (544)	23.1 (587)	27.7 (704)	260 (1678)	86/32 (68)
23.5-25	6WAR23	L-5S	24	19.50	2.5	66.2 (1681)	24.5 (632)	26.5 (673)	29.8 (757)	354 (2284)	95/32 (75)
26.5-25	6WAW27	L-5S	32	22.00	3.0	70.9 (1801)	28.0 (711)	29.2 (742)	32.4 (823)	329 (2123)	105/32 (83)
29.5-25	6SAUW1	L-5S	28	25.00	3.5	75.1 (1908)	30.0 (702)	31.8 (808)	33.4 (848)	634 (4088)	128/32 (102)
29.5-25	6SAXW1	L-5S	34	25.00	3.5	75.1 (1908)	30.0 (702)	31.8 (808)	33.4 (848)	640 (4126)	128/32 (102)
CAB 29.5-29	6WAXW2	L-5S	34	25.00	3.5	79.3 (2014)	30.2 (767)	32.2 (818)	35.0 (889)	608 (3923)	115/32 (91)
29.5-25	6WAUW1	L-5S	28	25.00	3.5	75.1 (1908)	30.0 (702)	31.9 (810)	33.5 (851)	575 (3710)	128/32 (102)
29.5-25	6WAXW1	L-5S	34	25.00	3.5	75.1 (1908)	30.0 (702)	31.9 (810)	33.5 (851)	575 (3710)	128/32 (102)
Belted 35/65-33	6SBC6B	L-5S	42	28.00	3.5	82.5 (2096)	35.7 (907)	37.5 (953)	36.7 (932)	755 (4871)	115/32 (91)
40/65-39	6SBV6C	L-5S	30	32.00	4.0	93.8 (2383)	39.8 (1011)	41.1 (1044)	42.1 (1069)	963 (6213)	128/32 (102)
41.25/70-39	6SBC6D	L-5S	42	32.00	4.5	99.3 (2522)	41.6 (1057)	43.5 (1105)	45.2 (1148)	1100 (7097)	140/32 (111)
45/65-45	6SBJ7E	L-5S	58	36.00	4.5	108.8 (2764)	44.0 (1118)	46.2 (1173)	48.7 (1237)	1397 (9013)	142/32 (113)

Bias Container Handling

Container Handling Tires

Bias-ply container handling tires are designed with high ply rating construction featuring an enlarged bead for increased stability in heavy service. Optional compound choices include: "Value Engineered" VE610 tread designed for long wear on concrete and asphalt, or "General Purpose" for all applications where the surface is not improved.



Titan LCM (L-3)

- Compact tread design provides excellent tread wear
- Directional tread design provides excellent traction

Tire Size	Catalog Number	Industry Code	Ply Rating	Rim Width Code	Flange Height Code	Outside Diameter in (mm)	Section Width in (mm)	Section Width Loaded in (mm)	Static Loaded Radius in (mm)	Gross Footprint Area in ² (cm ²)	Tread Depth in (mm)
VE610											
14.00-24NHS	6C1U44	L-3	28	10.00W	---	54.2 (1377)	15.4 (391)	16.1 (409)	25.3 (643)	180 (1161)	31/32 (25)
14.00-24NHS TL	YC1U44	L-3	28	10.00W*	---	54.2 (1377)	15.4 (391)	16.1 (409)	25.3 (643)	180 (1161)	31/32 (25)
21.00-25	6C1B22	L-3	40	15.00	3.0	70.7 (1796)	23.6 (599)	25.4 (645)	31.1 (790)	467 (3013)	43/32 (34)
GENERAL PURPOSE											
14.00-24NHS	6CLU44	L-3	28	10.00W	---	54.2 (1377)	15.4 (391)	16.1 (409)	25.3 (643)	180 (1161)	31/32 (25)
14.00-24NHS TL	YCLU44	L-3	28	10.00W*	---	54.2 (1377)	15.4 (391)	16.1 (409)	25.3 (643)	180 (1161)	31/32 (25)
21.00-25	6CNB22	L-3	40	15.00	3.0	70.7 (1796)	23.6 (599)	25.4 (645)	31.1 (790)	467 (3013)	43/32 (34)

*Tubeless Rim Required



Titan ND LCM (L-3)

- Non-directional tread design with center riding rib provides excellent traction and stability
- Rock service tread design provides long tread life

Tire Size	Catalog Number	Industry Code	Ply Rating	Rim Width Code	Flange Height Code	Outside Diameter in (mm)	Section Width in (mm)	Section Width Loaded in (mm)	Static Loaded Radius in (mm)	Gross Footprint Area in ² (cm ²)	Tread Depth in (mm)
VE610											
16.00-25	6N6W65	L-3	32	11.25	2.0	59.0 (1499)	17.5 (445)	18.8 (478)	26.8 (681)	204 (1316)	35/32 (28)
GENERAL PURPOSE											
16.00-25	6N3W65	L-3	32	11.25	2.0	59.0 (1499)	17.5 (445)	18.8 (478)	26.8 (681)	204 (1316)	35/32 (28)

Bias Container Handling



Titan ND Super LCM (L-4/E-4)

- Non-directional tread design with center riding rib provides excellent all around traction and lateral stability
- Increased tread depth provides extended tread life and exceptional resistance to rock type damage

Tire Size	Catalog Number	Industry Code	Ply Rating	Rim Width Code	Flange Height Code	Outside Diameter in (mm)	Section Width in (mm)	Section Width Loaded in (mm)	Static Loaded Radius in (mm)	Gross Footprint Area in ² (cm ²)	Tread Depth in (mm)
GENERAL PURPOSE											
18.00-25	6UNB18	L-4/E-4	40	13.00	2.5	64.7 (1643)	20.0 (508)	21.7 (551)	28.9(734)	246 (1587)	66/32 (52)
21.00-49	6U5C24	L-4/E-4	42	15.00	3.0	95.0 (2413)	22.6 (574)	24.2 (615)	44.2 (1123)	455 (2936)	66/32 (52)



Titan CH 150 (L-4) or (L-4/E-4)

- Deep, non-directional tread provides excellent damage resistance and long tread life
- Solid centerline tread pattern provides smooth ride and excellent lateral traction

Tire Size	Catalog Number	Industry Code	Ply Rating	Rim Width Code	Flange Height Code	Outside Diameter in (mm)	Section Width in (mm)	Section Width Loaded in (mm)	Static Loaded Radius in (mm)	Gross Footprint Area in ² (cm ²)	Tread Depth in (mm)
VE610											
18.00-25	6H6B18	L-4	40	13.00	2.5	65.1 (1654)	20.4 (518)	21.7 (551)	29.7 (754)	360 (2323)	66/32 (52)
GENERAL PURPOSE											
18.00-25	6HLB18	L-4/E-4	40	13.00	2.5	65.1 (1654)	20.4 (518)	21.7 (551)	29.7 (754)	360 (2323)	66/32 (52)



Titan CM 150 (L-4)

- Deep, non-directional tread provides excellent rock type damage resistance and long tread life
- Solid centerline tread pattern provides smooth ride and excellent lateral traction

Tire Size	Catalog Number	Industry Code	Ply Rating	Rim Width Code	Flange Height Code	Outside Diameter in (mm)	Section Width in (mm)	Section Width Loaded in (mm)	Static Loaded Radius in (mm)	Gross Footprint Area in ² (cm ²)	Tread Depth in (mm)
VE420											
21.00-35	6QSC25	L-4/E-4	42	15.00	3.0	81.0 (2057)	23.5 (597)	24.8 (630)	37.4 (950)	400 (2581)	71/32 (56)
27.00-49	6QSF79	L-4/E-4	48	19.50	4.0	106.5 (2705)	30.3 (769)	32.0 (812)	49.3(1252)	683 (4407)	78/32 (62)
VE610											
18.00-33	6M6B83	L-4	40	13.00	2.5	73.8 (1875)	20.4 (518)	21.5 (546)	34.9 (886)	314 (2026)	71/32 (56)
30.00-51	6M6H30	L-4	52	22.00	4.5	114.4E (2905)	32.5E (825)	34.8E (883)	52.7E (1399)	816E (5265)	85/32 (68)
GENERAL PURPOSE											
18.00-33	6M5B83	E-4/L-4	40	13.00	2.5	73.8 (1875)	20.4 (518)	21.5 (546)	34.9 (886)	314 (2026)	71/32 (56)



Titan Super Smooth (L-4S)

- Deep tread depth provides extended tread life
- Smooth tread design provides maximum damage resistance

Tire Size	Catalog Number	Industry Code	Ply Rating	Rim Width Code	Flange Height Code	Outside Diameter in (mm)	Section Width in (mm)	Section Width Loaded in (mm)	Static Loaded Radius in (mm)	Gross Footprint Area in ² (cm ²)	Tread Depth in (mm)
VE610											
18.00-25	646B18	L-4S	40	13.00	2.5	65.7 (1669)	19.8 (503)	21.7 (551)	29.6 (752)	282 (1819)	66/32 (52)
18.00-33	646B83	L-4S	40	13.00	2.5	73.8 (1875)	20.5 (521)	21.6 (549)	34.9 (886)	314 (2026)	66/32 (52)
GENERAL PURPOSE											
18.00-25	64SB18	L-4S	40	13.00	2.5	65.7 (1669)	19.8 (503)	21.7 (551)	29.6 (752)	282 (1819)	66/32 (52)



Titan Super Smooth (L-5S)

- Extra deep tread depth provides long tread life
- Smooth tread design provides the maximum damage resistance

Tire Size	Catalog Number	Industry Code	Ply Rating	Rim Width Code	Flange Height Code	Outside Diameter in (mm)	Section Width in (mm)	Section Width Loaded in (mm)	Static Loaded Radius in (mm)	Gross Footprint Area in ² (cm ²)	Tread Depth in (mm)
VE610											
18.00-25	656B18	L-5S	40	13.00	2.5	65.7 (1669)	19.8 (503)	21.5 (546)	29.7 (755)	275 (1774)	99/32 (79)
GENERAL PURPOSE											
18.00-25	65SB18	L-5S	40	13.00	2.5	65.7 (1669)	19.8 (503)	21.5 (546)	29.7 (755)	275 (1774)	99/32 (79)

Bias Underground Mine / Material Handling



Titan LD 250 Super Smooth UGM (L-5S)

- Super smooth tread pattern gives the maximum rock type damage resistance
- New underground mine compound
- CRB - Features Aralon Cut Resistant Breaker construction, which provides increased strength and durability without sacrificing heat resistance
- CAB - Features Cushion Armor Breaker steel belted construction, which gives increased cut resistance
- Belted 7x7 - Features 7x7 steel belted construction, which provides increased cut resistance and extended wear

Tire Size	Catalog Number	Industry Code	Ply Rating	Rim Width Code	Flange Height Code	Outside Diameter in (mm)	Section Width in (mm)	Section Width Loaded in (mm)	Static Loaded Radius in (mm)	Gross Footprint Area in ² (cm ²)	Tread Depth in (mm)
12.00-24NHS TT	SBT912	L-5S	20	8.50	---	48.3 (1227)	12.5 (318)	14.0E (356)	21.8 (554)	---	74/32 (59)
14.00-24NHS TT	SBT914	L-5S	20	10.00 W	---	54.1 (1373)	15.6 (396)	---	24.9 (632)	198 (5029)	102/32 (81)
17.5-25	SBT917	L-5S	20	14.00	1.5	55.2E (1402)	18.0E (457)	20.7E (526)	24.6E (625)	---	104/32 (83)
17.5-25	SBTR17	L-5S	24	14.00	1.5	55.2E (1402)	18.0E (457)	20.7E (526)	24.6E (625)	---	104/32 (83)
18.00-25	UGMW18	L-5S	32	13.00	2.5	65.7 (1669)	19.8 (503)	21.5 (546)	29.7 (755)	275 (1774)	99/32 (79)
CRB											
20.5-25	6SU921	L-5S	20	17.00	2.0	61.3 (1557)	21.3 (544)	23.1 (587)	27.7 (704)	260 (1678)	86/32 (68)
23.5-25	6SUR23	L-5S	24	19.50	2.5	66.2 (1681)	24.5 (632)	26.5 (673)	29.8 (757)	354 (2284)	95/32 (75)
CAB											
26.5-25	6SUW27	L-5S	32	22.00	3.0	70.9 (1801)	28.0 (711)	29.2 (742)	32.4 (823)	329 (2123)	105/32 (83)
29.5-25	6CUXW1	L-5S	34	25.00	3.5	75.1 (1908)	30.0 (762)	31.9 (810)	33.5 (851)	575 (3710)	128/32 (102)
Belted											
29.5-29	6SUXW2	L-5S	34	25.00	3.5	79.3 (2014)	30.2 (767)	32.2 (818)	35.0 (889)	608 (3923)	115/32 (91)
35/65-33	67UC6B	L-5S	42	28.00	3.5	82.5 (2096)	35.7 (907)	37.5 (953)	36.7 (932)	755 (4871)	115/32 (91)

E - Estimated
TT - Tube Type



Titan Industrial Deep Traction

- For extra heavy-duty applications requiring a narrow tire option for mining use
- Designed to withstand long, extended runs, this tire is easily one of the best tires for performance and durability
- Its unique broken bar/solid bar lug design provides increased footprint for better braking, handling and load distribution

Tire Size	Catalog Number*	Ply Rating*	Rim Width Code	Outside Diameter in (mm)	Section Width in (mm)	Static Loaded Radius in (mm)	Rolling Circ. in (mm)	Tread Depth in (mm)
6.90/6.00-9NHS	454204F	10	5.50	21.9 (556)	6.9 (175)	9.7 (246)	65 (1651)	19/32 (15)
6.50-10NHS	454263F	10	5.00	23.4 (594)	7.4 (188)	10.4 (264)	69 (1753)	20/32 (16)
7.50-10NHS	454287F	12	5.50	25.5 (648)	8.4 (213)	11.3 (287)	75 (1905)	22/32 (17)
7.00-12NHS	454212F	12	5.00	27.4 (696)	7.8 (198)	12.2 (310)	81 (2057)	21/32 (17)
7.00-12NHS	4542D7F	14	5.00	27.4 (696)	7.8 (198)	12.2 (310)	81 (2057)	21/32 (17)
7.50-15NHS	454269F	12	6.00	31.7 (805)	8.6 (218)	14.3 (363)	94 (2388)	22/32 (17)
8.25-15NHS	454231F	12	6.50	33.6 (853)	9.8 (249)	14.8 (376)	99 (2515)	23/32 (18)
8.25-15NHS	4542D5F	14	6.50	33.6 (853)	9.8 (249)	14.8 (276)	99 (2515)	23/32 (18)
29x8-15NHS	454216F	12	5.50	29.2 (742)	7.5 (191)	13.3 (338)	87 (2210)	125/32 (99)
30x8-15NHS	454251F	12	6.00	30.1 (765)	8.1 (206)	13.6 (345)	89 (2261)	125/32 (99)

*See Material Handling Tables for loads at various conditions on p. 84

*Ending in F indicates flap included

Bias Underground Mine / Material Handling



Titan T44

- Has proven success in the material handling and mining industries
- T44 also affords a comfortable ride with an extra thick carcass for better shock absorption
- Features an increased tread for better stability

Tire Size	TL/TT	Catalog Number	Ply Rating*	Rim Width Code	Outside Diameter in (mm)	Section Width in (mm)	Static Loaded Radius in (mm)	Rolling Circ. in (mm)	Tread Depth in (mm)
44x18.00-20NHS	TL	44T3K1	32	15.00T	43.6 (1107)	18.7 (475)	19.6 (498)	129 (3277)	38/32 (30)
42x21.00-22NHS	TL	44T3J5	32	18.00	43.8 (1113)	19.8 (503)	19.8 (503)	130 (3302)	25/32 (20)

*See Material Handling Tables for loads at various conditions on p. 84



Titan TT472

- The ultimate performance forklift tire
- Increased skid depth, a wider, flatter profile and a reinforced rim guard provides needed performance for the increased demands of the forklift industry

Tire Size	Catalog Number*	Ply Rating*	Rim Width Code	Outside Diameter in (mm)	Section Width in (mm)	Static Loaded Radius in (mm)	Rolling Circ. in (mm)	Tread Depth in (mm)
10.00-20NHS	472224F	18	7.50	42.2 (1072)	10.9 (277)	19.2 (488)	125 (3175)	38/32 (30)
12.00-20NHS	4722A7F	20	8.50	46.2 (1173)	12.4 (315)	20.9 (531)	136 (3454)	41/32 (33)

*See Material Handling Tables for loads at various conditions on p. 84

*Ending in F indicates flap included



Titan T40

- Designed for use with material handling and mining equipment
- Excellent flotation and load distribution properties

Tire Size	TL/TT	Catalog Number*	Ply Rating*	Rim Width Code	Outside Diameter in (mm)	Section Width in (mm)	Static Loaded Radius in (mm)	Rolling Circ. in (mm)	Tread Depth in (mm)
32x12-15NHS	TT	44P226F	20	9.75	32.2 (818)	11.5 (292)	14.5 (368)	96 (2438)	32/32 (25)
35x15-15NHS	TL	44P377	28	10.50	34.9 (886)	14.8 (376)	15.6 (396)	103 (2616)	29/32 (23)

*See Material Handling Tables for loads at various conditions on p. 84

*Ending in F indicates flap included

Bias Underground Mine / Material Handling



Titan PWT

- With a proven record in the material handling and mining industries, the Premium Wide Track features a non-directional lug design suited for vehicle drive or steer position
- Heavy duty sidewall

Tire Size	TL/TT	Catalog Number*	Ply Rating*	Rim Width Code	Outside Diameter in (mm)	Section Width in (mm)	Static Loaded Radius in (mm)	Rolling Circ. in (mm)	Tread Depth in (mm)
28x9-15NHS	TT	44P2B5F	12	7.00	27.3 (693)	8.8 (224)	12.5 (318)	81 (2057)	18/32 (14)
28x12-15NHS	TT	44P262F	20	9.75	28.1 (714)	11.5 (292)	12.8 (325)	84 (2134)	24/32 (19)
32x15-15NHS	TL	44P3G7	24	11.50	33.1 (841)	14.3 (363)	14.8 (376)	98 (2489)	32/32 (25)
36x11-15NHS	TT	44P2F9F	16	7.50	36 (914)	10.9 (277)	16.0 (406)	106 (2692)	29/32 (23)
36x11-15NHS	TT	44P6F9F	24	7.50	36 (914)	10.9 (277)	16.0 (406)	106 (2692)	29/32 (23)
9.00-20NHS	TT	44P218F	12	7.00	41 (1041)	10.6 (269)	18.5 (470)	121 (3073)	25/32 (20)
9.00-20NHS	TT	44P2E8F	14	7.00	41 (1041)	10.6 (269)	18.5 (470)	121 (3073)	25/32 (20)
10.00-20NHS	TT	44P2E9F	16	7.50	42.1 (1069)	11.6 (295)	18.9 (480)	124 (3150)	25/32 (20)
11.00-20NHS	TT	44P2E2F	16	8.00	43.1 (1095)	11.4 (290)	19.4 (493)	127 (3226)	26/32 (21)
12.00-20NHS	TT	44P2E3F	18	8.50	44.8 (1138)	13.1 (333)	20.0 (508)	132 (3353)	32/32 (25)
12.00-20NHS	TT	44P2A7F	20	8.50	44.8 (1138)	13.1 (333)	20.0 (508)	132 (3353)	32/32 (25)

*See Material Handling Tables for loads at various conditions on p. 84

*Ending in F indicates flap included



Titan Super LCM (L-4)

- Deep tread depth provides extended tread life
- Interlocking directional tread pattern provides excellent traction

Tire Size	Catalog Number	Industry Code	Ply Rating	Rim Width Code	Flange Height Code	Outside Diameter in (mm)	Section Width in (mm)	Section Width Loaded in (mm)	Static Loaded Radius in (mm)	Gross Footprint Area in ² (cm ²)	Tread Depth in (mm)
UGM											
16.00-25	6LUW65	L-4	32	11.25	2.0	59.6 (1514)	17.5 (445)	18.5 (470)	27.6 (701)	204 (1316)	52/32 (41)



Goodyear Logger Lug III (LS-2)

- Optimal lug angle provides optimized balance between traction and cut resistance
- Special forestry compound for increased resistance to tread chunking and tearing
- Steel belt construction provides excellent penetration resistance

Tire Size	TL/TT	Catalog Number	Ply Rating	Rim Width Code	20 mph (30 kph)	5mph (10 kph)	Outside Diameter in (mm)	Section Width in (mm)	Section Width Loaded in (mm)	Static Loaded Radius in (mm)	Tread Depth in (mm)
					Load/Inflation lbs. @ PSI (kg @ bar)						
18.4-26	TT	LL3056	10	DW16A	5,680 @ 25 (2,575 @ 1.7)	7,950 @ 30 (3,600 @ 2.1)	58.2 (1478)	18.4 (467)	19.8 (503)	26.7 (678)	63/32 (50)
18.4-34	TT	LL3054	10	DW16A	6,400 @ 25 (2,900 @ 1.7)	8,950 @ 30 (4,060 @ 2.1)	65.7 (1669)	18.4 (467)	19.8 (503)	29.9 (759)	63/32 (50)
23.1-26	TT	LL3586	16	DW20A	9,900 @ 35 (4,500 @ 2.4)	13,900 @ 40 (6,300 @ 2.8)	64.2 (1631)	23.5 (597)	24.8 (630)	29.3 (744)	72/32 (57)
23.1-26	TL	YL3586	16	DW20A	9,900 @ 35 (4,500 @ 2.4)	13,900 @ 40 (6,300 @ 2.8)	64.2 (1631)	23.5 (597)	24.8 (630)	29.3 (744)	72/32 (57)
24.5-32	TT	LL3599	16	DH21	11,000 @ 30 (5,000 @ 2.1)	15,400 @ 35 (7,000 @ 2.4)	71.7 (1821)	25.2 (640)	26.4 (671)	32.7 (831)	64/32 (53)
24.5-32	TL	YL3599	16	DH21	11,000 @ 30 (5,000 @ 2.1)	15,400 @ 35 (7,000 @ 2.4)	71.7 (1821)	25.2 (640)	26.4 (671)	32.7 (831)	64/32 (53)



Goodyear Logger Lug III HD (LS-2)

- Four steel belted construction provides maximum impact and penetration resistance in heavy-duty service
- Optimal lug angle provides optimized balance between traction and cut resistance
- Special forestry compound for increased resistance to tread chunking and tearing

Tire Size	TL/TT	Catalog Number	Ply Rating	Rim Width Code	20 mph (30 kph)	5mph (10 kph)	Outside Diameter in (mm)	Section Width in (mm)	Section Width Loaded in (mm)	Static Loaded Radius in (mm)	Tread Depth in (mm)
					Load/Inflation lbs. @ PSI (kg @ bar)						
23.1-26	TT	LL7586	16	DW20A	9,900 @ 35 (4,500 @ 2.4)	13,900 @ 40 (6,300 @ 2.8)	64.2 (1631)	23.5 (597)	24.8 (630)	29.3 (744)	72/32 (57)
24.5-32	TT	LL7799	18	DH21	12,000 @ 35 (5,450 @ 2.4)	16,800 @ 40 (7,600 @ 2.8)	71.7 (1821)	25.2 (640)	26.4 (671)	32.7 (831)	64/32 (53)
24.5-32	TL	YL7799	18	DH21	12,000 @ 35 (5,450 @ 2.4)	16,800 @ 40 (7,600 @ 2.8)	71.7 (1821)	25.2 (640)	26.4 (671)	32.7 (831)	64/32 (53)
28L-26	TT	LL7998	20	DW25A	11,400 @ 35 (5,150 @ 2.4)	16,000 @ 40 (7,300 @ 2.8)	64.8 (1646)	28.0 (711)	28.8 (732)	29.3 (744)	74/32 (58)
28L-26	TL	YL7998	20	DW25A	11,400 @ 35 (5,150 @ 2.4)	16,000 @ 40 (7,300 @ 2.8)	64.8 (1646)	28.0 (711)	28.8 (732)	29.3 (744)	74/32 (58)
30.5L-32	TT	LL7996	20	DH27	13,200 @ 30 (6,000 @ 2.1)	18,500 @ 40 (8,400 @ 2.4)	74.0 (1880)	30.5 (775)	31.8 (808)	33.3 (846)	70/32 (56)
30.5L-32	TL	YL7996	20	DH27	13,200 @ 30 (6,000 @ 2.1)	18,500 @ 40 (8,400 @ 2.4)	74.0 (1880)	30.5 (775)	31.8 (808)	33.3 (846)	70/32 (56)
30.5L-32	TT	LL7T96	26	DH27	15,700 @ 40 (7,100 @ 2.8)	22,000 @ 45 (10,000 @ 3.1)	74.0 (1880)	30.5 (775)	31.8 (808)	33.3 (846)	70/32 (56)
30.5L-32	TL	YL7T96	26	DH27	15,700 @ 40 (7,100 @ 2.8)	22,000 @ 45 (10,000 @ 3.1)	74.0 (1880)	30.5 (775)	31.8 (808)	33.3 (846)	70/32 (56)
DH35.5L-32	TT	LL79D5	20	DH31	16,100 @ 25 (7,300 @ 1.7)	22,500 @ 30 (10,200 @ 2.1)	78.9 (2004)	35.9 (912)	36.9 (937)	35.3 (897)	75/32 (60)
DH35.5L-32	TL	YL79D5	20	DH31	16,100 @ 25 (7,300 @ 1.7)	22,500 @ 30 (10,200 @ 2.1)	78.9 (2004)	35.9 (912)	36.9 (937)	35.3 (897)	75/32 (60)
DH35.5L-32	TT	LL7TD5	26	DH31	19,300 @ 35 (8,750 @ 2.4)	27,000 @ 40 (12,150 @ 2.8)	78.9 (2004)	35.9 (912)	36.9 (937)	35.3 (897)	75/32 (60)
DH35.5L-32	TL	YL7TD5	26	DH31	19,300 @ 35 (8,750 @ 2.4)	27,000 @ 40 (12,150 @ 2.8)	78.9 (2004)	35.9 (912)	36.9 (937)	35.3 (897)	75/32 (60)

Bias Forestry



Goodyear Logger Lug III Flotation (HF-4)

- Extra wide tread for high flotation in wet terrain while providing low ground penetration to minimize environmental impact
- Special forestry compound for increased resistance to tread chunking and tearing
- Four steel belted construction provides excellent penetration resistance

Tire Size	Catalog Number	Ply Rating	Rim Width Code	30 mph (50 kph)	5mph (10 kph)	Outside Diameter in (mm)	Section Width in (mm)	Section Width Loaded in (mm)	Static Loaded Radius in (mm)	Tread Depth in (mm)
				Load/Inflation lbs. @ PSI (kg @ bar)						
66x43.00-25NHS	YL33F3	14	36.0TH	12,300 @ 35 (5,600 @ 2.4)	19,400 @ 35 (8,800 @ 2.4)	69.4 (1763)	41.2 (1046)	41.5 (1054)	32.9 (836)	112/32 (89)
66x43.00-25NHS	YL39F3	20	36.0TH	14,800 @ 50 (6,700 @ 3.4)	23,400 @ 50 (10,600 @ 3.4)	69.4 (1763)	41.2 (1046)	41.5 (1054)	32.9 (836)	112/32 (89)
66x43.00-26NHS	YL33F6	14	DW36A	12,000 @ 35 (5,450 @ 2.4)	19,000 @ 35 (8,600 @ 2.4)	69.4 (1763)	41.2 (1046)	41.5 (1054)	32.9 (836)	112/32 (89)
66x43.00-26NHS	YL39F6	20	DW36A	14,800 @ 50 (6,700 @ 3.4)	23,400 @ 50 (10,600 @ 3.4)	69.4 (1763)	41.2 (1046)	41.5 (1054)	32.9 (836)	112/32 (89)
67x34.00-25NHS	YL33R3	14	30.0TH	13,200 @ 40 (6,000 @ 2.8)	20,900 @ 40 (9,500 @ 2.8)	69.4 (1763)	34.1 (866)	34.4 (874)	32.2 (818)	118/32 (94)
67x34.00-26NHS	YL3R65	14	DW30A	13,200 @ 40 (6,000 @ 2.8)	20,900 @ 40 (9,500 @ 2.8)	69.4 (1763)	34.1 (866)	34.4 (874)	32.2 (818)	118/32 (94)
DH73x44.00-32*	YL35R6	16	DH36	15,200 @ 40 (6,900 @ 2.8)	24,000 @ 40 (10,900 @ 2.8)	74.9 (1902)	41.3 (1049)	41.4 (1052)	35.5 (902)	104/32 (83)
DH73x44.00-32*	YL39R6	20	DH36	17,600 @ 50 (7,950 @ 3.4)	27,800 @ 50 (12,600 @ 3.4)	74.2 (1885)	41.8 (1062)	41.9 (1064)	35.4 (899)	104/32 (83)
DH73x50.00-32*	YL35V6	16	DH44	14,800 @ 35 (6,700 @ 2.4)	23,400 @ 35 (10,600 @ 2.4)	75.3 (1913)	50.1 (1273)	--	--	104/32 (83)
DH73x50.00-32*	YL39V6	20	DH44	17,100 @ 45 (7,750 @ 3.1)	27,000 @ 45 (12,250 @ 3.1)	74.4 (1890)	49.1 (1247)	49.2 (1250)	36.8(935)	104/32 (83)

*HF-3+ Tread depth is greater than HF-3 but less than HF-4



IT510



IT520



IT525



IT530

Goodyear IT510 (R-4)

- Maximum traction supplied by additional biting edges from the overlapping lug/block pattern
- Flotation and traction provided by a larger contact patch
- Industrial use applications

Goodyear IT520 (R-4)

- Outstanding soft soil traction
- Reinforced lugs for deeper grip and extended wear
- Industrial use applications

Goodyear IT525 (R-4)

- Solid performance on rock-hard ground
- Increased wear and performance on hard surfaces
- Excellent traction in soft soils

Goodyear IT530 (R-4)

- Excellent hard soil traction
- High puncture resistance
- Refined road comfort

Tire Size	Catalog Number	Design	Industry Code	Load Rating	Inflation Pressure PSI (bar)	Max Speed mph (km/h)	Max Load lbs (kg)	Rim Width Code	Overall Diameter in (mm)	Section Width in (mm)	Static Loaded Radius in (mm)	Rolling Circ. in (mm)	Gross Foot-print Area in ² (cm ²)	Weight lbs (kg)	Tread Depth in (mm)
19.5LR24**	451461	IT510	R-4	152A8/B	38 (2.8)	30 (50)	7,850 (3,550)	16.00	51.9 (1318)	18.7 (475)	22.8 (579)	156 (3962)	225 (1452)	218 (99)	33/32 (26)
500/70R24	452661	IT520	R-4	157A8/B	46 (3.2)	30 (50)	9,100 (4,125)	16.00	51.3 (1303)	19.2 (488)	22.9 (582)	155 (3937)	297 (1916)	251 (114)	44/32 (35)
500/70R24	4L2661GY#	IT520	R-4	157A8/B	46 (3.2)	30 (50)	9,100 (4,125)	16.00	51.3 (1303)	19.2 (488)	22.9 (582)	155 (3937)	297 (1916)	247 (112)	44/32 (35)
500/70R24	453661	IT530	R-4	157A8/B	46 (3.2)	30 (50)	9,100 (4,125)	16.00	51.6 (1311)	19.5 (495)	23.0 (584)	154 (3912)	227 (1465)	241 (109.5)	34/32 (27)
500/85R24**	45R464	IT525	R-4	171A8/B	61 (4.2)	30 (50)	13,600 (6,150)	16.00	54.0 (1372)	18.4 (467)	24.5 (622)	163 (4140)	273 (1761)	300 (136)	34/32 (27)
500/85R24	452564	IT520	R-4	171A8/B	61 (4.2)	30 (50)	13,600 (6,150)	16.00	55.8 (1417)	19.5 (495)	25.0 (635)	166 (4216)	288 (1858)	304 (138)	44/32 (27)
540/70R24**	453675	IT530	R-4	161A8/B	46 (3.2)	30 (50)	10,200 (4,625)	18.00	53.8 (1367)	21.7 (551)	23.9 (607)	161 (4089)	235 (1517)	292 (132)	36/32 (29)

Stubble Resistant
 ** Minimum Quantity Order

Bias Backhoe



IT515



IT525

Goodyear IT515 HS (R-4)

- Designed for backhoe/loader operations on hard surface
- More lugs for improved puncture resistance
- Better durability provided by the natural shaped carcass

Goodyear IT525 (R-4)

- Solid performance on rock-hard ground
- Increased wear and performance on hard surfaces

Tire Size	Catalog Number	Design	Industry Code	Ply Rating	Inflation Pressure PSI (bar)	Max Speed mph (km/h)	Max Load lbs (kg)	Rim Width Code	Overall Diameter in (mm)	Section Width in (mm)	Static Loaded Radius in (mm)	Rolling Circ. in (mm)	Gross Footprint Area in ² (cm ²)	Weight lbs (kg)	Tread Depth in (mm)
14.9-24	45T834	IT525	R-4	8	30 (2.1)	25 (40)	5,080 (2,300)	13.00	48.9 (1242)	15.0 (381)	22.4 (569)	145 (3683)	140 (904)	133 (60.5)	32/32 (25)
14.9-24	45T134	IT525	R-4	12	42 (2.9)	25 (40)	6,400 (2,900)	13.00	48.9 (1242)	15.0 (381)	22.4 (569)	145 (3683)	140 (904)	145 (66)	32/32 (25)
16.9-24	45T845	IT525	R-4	8	28 (1.9)	25 (40)	5,840 (2,650)	15.00	51.0 (1295)	16.9 (429)	23.0 (584)	151 (3835)	194 (1252)	149 (67.5)	33/32 (26)
16.9-24	45T045	IT525	R-4	10	32 (2.2)	25 (40)	6,400 (2,900)	15.00	51.0 (1295)	16.9 (429)	23.0 (584)	151 (3835)	194 (1252)	162 (73.5)	33/32 (26)
16.9-24	45T145	IT525	R-4	12	38 (2.6)	25 (40)	7,150 (3,250)	15.00	51.0 (1295)	16.9 (429)	23.0 (584)	151 (3835)	194 (1252)	163 (74)	33/32 (26)
16.9-28	45T848	IT525	R-4	8	28 (1.9)	25 (40)	6,150 (2,800)	15.00	55.5 (1410)	16.9 (429)	25.1 (638)	165 (4191)	223 (1439)	177 (80.5)	33/32 (26)
16.9-28	45T048	IT525	R-4	10	32 (2.2)	25 (40)	6,800 (3,075)	15.00	55.6 (1412)	16.9 (429)	24.5 (622)	163 (4140)	216 (1394)	192 (87)	33/32 (26)
16.9-28	45T148	IT525	R-4	12	38 (2.6)	25 (40)	7,600 (3,450)	15.00	55.5 (1410)	16.9 (429)	25.1 (638)	165 (4191)	223 (1439)	193 (87.5)	33/32 (26)
17.5L-24	45T803	IT525	R-4	8	26 (1.8)	25 (40)	5,360 (2,430)	15.00	48.6 (1234)	17.4 (442)	21.9 (556)	144 (3658)	192 (1239)	151 (68.5)	32/32 (25)
17.5L-24	45T003	IT525	R-4	10	32 (2.2)	25 (40)	6,150 (2,800)	15.00	48.6 (1234)	17.4 (442)	21.9 (556)	144 (3658)	192 (1239)	165 (75)	32/32 (25)
18.4-24	45T164	IT525	R-4	12	36 (2.5)	25 (40)	8,250 (3,750)	16.00	54.1 (1374)	18.4 (467)	24.2 (615)	160 (4064)	246 (1588)	194 (88)	34/32 (27)
19.5L-24	45T061	IT525	R-4	10	28 (1.9)	25 (40)	6,600 (3,000)	16.00	52.0 (1321)	19.0 (483)	23.7 (602)	154 (3912)	206 (1329)	202 (91.5)	34/32 (27)
19.5L-24	45T161	IT525	R-4	12	34 (2.3)	25 (40)	7,600 (3,400)	16.00	52.0 (1321)	19.0 (483)	23.7 (602)	154 (3912)	206 (1329)	209 (95)	34/32 (27)
19.5L-24	4H5161	IT515 HS	R-4	12	34 (2.3)	25 (40)	7,600 (3,400)	16.00	52.5 (1334)	20.2 (513)	23.7 (602)	156 (3962)	208 (1342)	232 (105)	34/32 (27)
19.5L-24	45T361#	IT525	R-4	14	38 (2.6)	25 (40)	8,250 (3,750)	16.00	52.0 (1321)	19.0 (483)	23.7 (602)	154 (3912)	238 (1536)	221 (100)	34/32 (27)
21L-24	45T075	IT525	R-4	10	26 (1.8)	25 (40)	7,400 (3,450)	18.00	54.2 (1377)	20.8 (528)	24.3 (617)	160 (4064)	238 (1536)	255 (115.5)	34/32 (27)
21L-24	45T175	IT525	R-4	12	32 (2.2)	25 (40)	8,550 (3,875)	18.00	54.2 (1377)	20.8 (528)	24.3 (617)	160 (4064)	238 (1536)	257 (116.5)	34/32 (27)
21L-24	45T575	IT525	R-4	16	40 (2.8)	25 (40)	9,900 (4,500)	18.00	54.2 (1377)	20.8 (528)	24.3 (617)	160 (4064)	238 (1536)	277 (125.5)	34/32 (27)
21L-28	45T376	IT525	R-4	14	36 (2.5)	25 (40)	9,900 (4,500)	18.00	58.2 (1478)	21.0 (533)	26.4 (671)	172 (4369)	260 (1678)	310 (140.5)	34/32 (27)

- Stubble Resistant



Sure Grip Lug



Industrial Sure Grip Lug

Goodyear Sure Grip Lug (R-4)

- Good Choice for industrial equipment
- Good traction and long wear provided by the wide, sturdy overlapping lugs

Goodyear Industrial Sure Grip (R-4)

- Reinforced lugs for industrial use
- Aggressive tread design

Tire Size	Catalog Number	Design	Industry Code	Ply Rating	Inflation Pressure PSI (bar)	Max Speed mph (km/h)	Max Load lbs (kg)	Rim Width Code	Overall Diameter in (mm)	Section Width in (mm)	Static Loaded Radius in (mm)	Rolling Circ. in (mm)	Gross Footprint Area in ² (cm ²)	Weight lbs (kg)	Tread Depth in (mm)
12.4-16	4GL483	Sure Grip Lug	R-4	4	20 (1.4)	25 (40)	2,070 (940)	11.00	36.9 (937)	12.8 (325)	16.7 (424)	110 (2,794)	95 (613)	84 (38)	30/32 (24)
14.9-24	SG1634	Industrial Sure Grip	R-4	6	20 (1.4)	25 (40)	3,000 (1,360)	13.00	48.9 (1242)	15.0 (381)	22.4 (569)	145 (3,683)	140 (904)	130 (59)	32/32 (25.5)
18.4-28	SG1158	Industrial Sure Grip	R-4	12	36 (2.5)	25 (40)	8,800 (4,000)	16.00	58.1 (1476)	18.8 (478)	26.2 (665)	172 (4,369)	256 (1652)	231 (105)	35/32 (28)



Industrial Tractor Lug/Contractor



Industrial Tractor Lug II

Titan Industrial Tractor Lug (R-4) Titan Industrial Contractor (R-4)

- Extra wide lugs with extensive overlap at the center, designed to resist buckling, tearing and cracking
- Excellent tread wear and roadability, the laterally designed lugs result in even wear

Titan Industrial Tractor Lug II (R-4)

- Features increased contact area for better traction and superior compound for improved abrasion resistance

Tire Size	Catalog Number	Design	Industry Code	Ply Rating	Inflation Pressure PSI (bar)	Max Speed mph (km/h)	Max Load lbs (kg)	Rim Width Code	Overall Diameter in (mm)	Section Width in (mm)	Static Loaded Radius in (mm)	Rolling Circ. in (mm)	Gross Footprint Area in ² (cm ²)	Weight lbs (kg)	Tread Depth in (mm)
14.9-24	486634	Industrial Tractor	R-4	6	24 (1.7)	25 (40)	4,300(1,950)	13.00	48.1 (1,222)	15.3 (389)	22.0 (559)	143 (3,632)	140E (903)	147 (66.5)	34/32 (27)
14.9-24	486834	Industrial Tractor	R-4	8	30 (2.1)	25 (40)	5,080 (2,300)	13.00	48.1 (1,222)	15.3 (389)	22.0 (559)	143 (3,632)	140E (903)	147 (66.5)	34/32 (27)
14.9-24	486134	Industrial Tractor	R-4	12	42 (2.9)	25 (40)	6,400 (2,900)	13.00	48.1 (1,222)	15.3 (389)	22.0 (559)	143 (3,632)	140E (903)	167 (76)	34/32 (27)
420/70-24	4866T2	Industrial Tractor	R-4	6	20 (1.4)	25 (40)	3,960 (1,800)	13.00	46.4 (1,179)	16.5 (419)	21.1 (536)	137 (3,480)	165 (1065)	155 (70)	35/32 (28)
16.9-24	486845	Industrial Tractor	R-4	8	28 (1.9)	25 (40)	5,840 (2,650)	15.00	50.6 (1,285)	17.4 (442)	23.0 (584)	153 (3,886)	194E (1252)	167 (76)	35/32 (28)
16.9-24	486045	Industrial Tractor	R-4	10	32 (2.2)	25 (40)	6,400 (2,900)	15.00	50.6 (1,285)	17.4 (442)	23.0 (584)	153 (3,886)	194E (1252)	173 (78.5)	35/32 (28)
16.9-24	486145	Industrial Tractor	R-4	12	38 (2.6)	25 (40)	7,150 (3,250)	15.00	50.6 (1,285)	17.4 (442)	23.0 (584)	153 (3,886)	194E (1252)	177 (80)	35/32 (28)
16.9-24	486345	Industrial Tractor	R-4	14	44 (3.0)	25 (40)	7,850 (3,550)	15.00	50.6 (1,285)	17.4 (442)	23.0 (584)	153 (3,886)	194E (1,252)	180 (81.5)	35/32 (28)
16.9-28	486848	Industrial Tractor	R-4	8	28 (1.9)	25 (40)	6,150 (2,800)	15.00	54.6 (1,387)	17.4 (442)	25.0 (635)	162 (4,115)	223E (1,439)	180 (81.5)	34/32 (27)
16.9-28	486148	Industrial Tractor	R-4	12	38 (2.6)	25 (40)	7,600 (3,450)	15.00	54.6 (1,387)	17.4 (442)	25.0 (635)	162 (4,115)	223E (1,439)	201 (91)	34/32 (27)
17.5L-24	4D6603	Industrial Contractor	R-4	6	20 (1.4)	25 (40)	4,400 (2,000)	15.00	48.8 (1,240)	17.1 (434)	22.3 (566)	145 (3,683)	192E (1,239)	153 (69.5)	32/32 (25)
17.5L-24	486603	Industrial Tractor	R-4	6	20 (1.4)	25 (40)	4,400 (2,000)	15.00	48.8 (1,240)	17.1 (434)	22.3 (566)	145 (3,683)	192E (1,239)	153 (69.5)	32/32 (25)
17.5L-24	486803	Industrial Tractor	R-4	8	26 (1.8)	25 (40)	5,360 (2,430)	15.00	48.8 (1,240)	17.1 (434)	22.3 (566)	145 (3,683)	192E (1,239)	153 (69.5)	32/32 (25)
17.5L-24	486003	Industrial Tractor	R-4	10	32 (2.2)	25 (40)	6,150 (2,800)	15.00	48.8 (1,240)	17.1 (434)	22.3 (566)	145 (3,683)	192E (1,239)	167 (76)	32/32 (25)
17.5L-24	4D6103	Industrial Contractor	R-4	12	36 (2.5)	25 (40)	6,600 (3,000)	15.00	48.8 (1,240)	17.1 (434)	22.3 (566)	145 (3,683)	192E (1,239)	173 (78.5)	32/32 (25)
17.5L-24	486103	Industrial Tractor	R-4	12	36 (2.5)	25 (40)	6,600 (3,000)	15.00	48.8 (1,240)	17.1 (434)	22.3 (566)	145 (3,683)	192E (1,239)	173 (78.5)	32/32 (25)
18.4-24	486864	Industrial Tractor	R-4	8	24 (1.7)	25 (40)	6,400 (2,900)	16.00	53.8 (1,367)	18.8 (478)	24.4 (620)	160 (4,064)	246E (1,587)	196 (89)	35/32 (28)
18.4-24	486164	Industrial Tractor	R-4	12	36 (2.5)	25 (40)	8,250 (3,750)	16.00	53.8 (1,367)	18.8 (478)	24.4 (620)	160 (4,064)	246E (1,587)	218 (99)	35/32 (28)
18.4-26	486056	Industrial Tractor	R-4	10	30 (2.1)	25 (40)	7,600 (3,450)	16.00	55.8 (1,417)	18.8 (478)	25.1 (638)	166 (4,216)	252E (1,626)	239 (108.5)	35/32 (28)
18.4-26	486156	Industrial Tractor	R-4	12	36 (2.5)	25 (40)	8,800 (4,000)	16.00	55.8 (1,417)	18.8 (478)	25.1 (638)	166 (4,216)	252E (1,626)	239 (108.5)	35/32 (28)
18.4-28	486058	Industrial Tractor	R-4	10	30 (2.1)	25 (40)	7,850 (3,550)	16.00	57.8 (1,468)	18.8 (478)	26.4 (671)	172 (4,369)	256E (1,652)	225 (102)	35/32 (28)
19.5L-24	486861	Industrial Tractor	R-4	8	24 (1.7)	25 (40)	6,000 (2,750)	17.00	51.8 (1,316)	19.1 (485)	23.5 (597)	154 (3,912)	206E (1,329)	190 (86)	34/32 (27)
19.5L-24	486061	Industrial Tractor	R-4	10	28 (1.9)	25 (40)	6,600 (3,000)	17.00	51.8 (1,316)	19.1 (485)	23.5 (597)	154 (3,912)	206E (1,329)	204 (92.5)	34/32 (27)
19.5L-24	486161	Industrial Tractor	R-4	12	34 (2.3)	25 (40)	7,600 (3,450)	17.00	51.8 (1,316)	19.1 (485)	23.5 (597)	154 (3,912)	206E (1,329)	209 (95)	34/32 (27)
21L-24	486175	Industrial Tractor	R-4	12	32 (2.2)	25 (40)	8,550 (3,875)	18.00	54.3 (1,379)	21.0 (533)	24.6 (625)	161 (4,089)	238E (1,535)	251 (114)	35/32 (28)
21L-28	486376	Industrial Tractor	R-4	14	36 (2.5)	25 (40)	9,900 (4,500)	18.00	58.3 (1,481)	21.0 (533)	26.6 (676)	173 (4,394)	260E (1,677)	337 (153)	36/32 (29)



Titan LSW Industrial Tractor Lug II (R-4)

Tire Size	Catalog Number	Industry Code	Ply Rating	Inflation Pressure PSI (bar)	Max Speed mph (km/h)	Max Load lbs (kg)	Rim Width Code	Overall Diameter in (mm)	Section Width in (mm)	Static Loaded Radius in (mm)	Rolling Circ. in (mm)	Gross Footprint Area in ² (cm ²)	Weight lbs (kg)	Tread Depth in (mm)
LSW500/60D28	G9FD61	R-4	14	34 (2.3)	25 (40)	7,600 (3,450)	17.00	51.9 (1,318)	18.8 (478)	23.3 (592)	155 (3,937)	232 (1,497)	220 (100)	34/32 (27)

Bias Backhoe



Laborer



Multi Rib

Goodyear Laborer (F-3)

- Industrial use for rugged applications
- Resists tearing and cracking with special tread compound
- Excellent handling and mobility with its five-rib design

Goodyear Multi Rib (F-3)

- Easy mobility with the rounded shoulder design
- Withstands scuffing, abrasions and bruises with the reinforced sidewall construction

Tire Size	TL/TT	Catalog Number	Design	Industry Code	Ply Rating	Inflation Pressure PSI (bar)	Max Speed mph (km/h)	Max Load lbs (kg)	Rim Width Code	Overall Diameter in (mm)	Section Width in (mm)	Static Loaded Radius in (mm)	Rolling Circ. in (mm)	Gross Footprint Area in ² (cm ²)	Weight lbs (kg)	Tread Depth in (mm)
9.00-10SL	TL	4MR3T8	Multi Rib	F-3	10	60 (4.1)	25 (40)	1,820 (825)	6.00	26.0 (660)	9.4 (239)	11.9 (302)	76 (1,930)	38 (245)	31 (14)	10/32 (8)
11L-15SL	TL	4LT318	Laborer	F-3	8	44 (3.0)	25 (40)	2,090 (950)	8.00	30.8 (782)	11.3 (287)	14.1 (358)	90 (2,286)	56 (361)	46 (21)	12/32 (10)
11L-15SL	TL	4LT310	Laborer	F-3	10	52 (3.6)	25 (40)	2,340 (1,060)	8.00	30.8 (782)	11.3 (287)	14.1 (358)	90 (2,286)	56 (361)	46 (21)	12/32 (10)
11L-16SL	TL	4LT315	Laborer	F-3	10	52 (3.6)	25 (40)	2,470 (1,120)	8.00	31.8 (808)	11.2 (284)	14.7 (373)	94 (2,388)	60 (387)	56 (25.5)	16/32 (13)
11L-16SL	TL	4LT317	Laborer	F-3	12	64 (4.4)	25 (40)	2,760 (1,250)	8.00	31.8 (808)	11.2 (284)	14.7 (373)	94 (2,388)	60 (387)	63 (28.5)	16/32 (13)
14.5/75-16.1SL	TL	4LT388	Laborer	F-3	10	40 (2.8)	25 (40)	3,200 (1,450)	11.00	36.0 (914)	14.7 (373)	16.5 (419)	105 (2,667)	120 (774)	99 (45)	19/32 (15)
14.5/75-16.1SL	TL	4LT588	Laborer	F-3	14	56 (3.9)	25 (40)	3,960 (1,795)	11.00	36.0 (914)	14.7 (373)	16.5 (419)	105 (2,667)	120 (774)	102 (46)	19/32 (15)



Contractor



Industrial Front Tractor

Titan Contractor (F-3)

- Low section height design for loader backhoe applications
- Designed for excellent durability and good road handling characteristics

Titan Industrial Front Tractor (F-3)

- Designed for excellent durability
- Good road handling characteristics for industrial service

Tire Size	Catalog Number	Design	Industry Code	Ply Rating*	Inflation Pressure PSI (bar)	Max Speed mph (km/h)	Max Load lbs (kg)	Rim Width Code	Overall Diameter in (mm)	Section Width in (mm)	Static Loaded Radius in (mm)	Rolling Circ. in (mm)	Gross Footprint Area in ² (cm ²)	Weight lbs (kg)	Tread Depth in (mm)
11L-15SL	465318	Contractor	F-3	8	44 (3.0)	25 (40)	2,090 (950)	8.00	31.3 (795)	11.0 (279)	14.5 (368)	93 (2,362)	56E (361)	53 (24)	15/32 (12)
11L-15SL	465310	Contractor	F-3	10	52 (3.6)	25 (40)	2,340 (1,060)	8.00	31.3 (795)	11.0 (279)	14.5 (368)	93 (2,362)	56E (361)	55 (25)	15/32 (12)
11L-16SL	465315	Contractor	F-3	10	52 (3.6)	25 (40)	2,470 (1,120)	8.00	32.3 (820)	11.0 (279)	15.0 (381)	96 (2,438)	60E (387)	56 (25.5)	15/32 (12)
11L-16SL	465317	Contractor	F-3	12	64 (4.4)	25 (40)	2,760 (1,250)	8.00	32.3 (820)	11.0 (279)	15.0 (381)	96 (2,438)	60E (387)	63 (28.5)	15/32 (12)
11.00-16SL	464396	Industrial Front Tractor	F-3	12	60 (4.1)	25 (40)	3,420 (1,550)	10.00	36.1 (917)	12.2 (310)	16.6 (422)	107 (2,718)	82E (529)	78 (35.5)	15/32 (12)
14.5/75-16.1SL	465388	Contractor	F-3	10	40 (2.8)	25 (40)	3,200 (1,450)	11.00	35.5 (902)	13.7 (348)	16.4 (417)	105 (2,667)	120E (774)	75 (34)	18/32 (14)
480/45-17	4652Q3	Contractor	F-3	134A8/B	29 (2.0)	30 (50)	4,680 (2,120)	16.00	34.0E (864)	19.3E (490)	15.4E (391)	101E (2,565)	150E (968)	83 (37.5)	15/32 (12)
480/45-17	4653Q3	Contractor	F-3	146A8/B	46 (3.2)	30 (50)	6,600 (2,995)	16.00	34.0 (864)	19.3 (490)	15.4 (391)	101 (2,565)	150E (968)	86 (39)	15/32 (12)
480/45-17	4657Q3	Contractor	F-3	153A8/B	58 (4.0)	30 (50)	8,050 (3,650)	16.00	34.0E (864)	19.3E (490)	15.4E (391)	101E (2,565)	150E (968)	89 (40.5)	15/32 (12)
480/45-17	4658Q3	Contractor	F-3	155A8/B	73 (5.0)	30 (50)	8,550 (3,875)	16.00	34.0E (864)	19.3E (490)	15.4E (391)	101E (2,565)	150E (968)	96 (43.5)	15/32 (12)

E -Estimated

*Tires with service descriptions, e.g.: 134 A8/B, not ply rating



TRACTION IMPLEMENT



SURE GRIP TRACTION

Goodyear Traction Implement (I-3)

- Traction design for implement service

Goodyear Sure Grip Traction (I-3)

- Ruler straight lugs for grip with even, steady pull
- Excellent cleanability provided by the open tread center
- Aggressive lug design



SURE GRIP LUG



CONTRACTOR

Goodyear Sure Grip Lug (I-3)

- Good choice for industrial equipment
- Good traction and long wear
- Wide, sturdy overlapping lugs

Goodyear Contractor (I-3)

- Excellent traction and wear are the benefits of the broad, curved lugs
- High strength construction gives it exceptional durability

Tire Size	Catalog Number	Design	Industry Code	Ply Rating	Inflation Pressure PSI (bar)	Max Speed mph (km/h)	Max Load lbs (kg)	Rim Width Code	Section Width in (mm)	Overall Diameter in (mm)	Static Loaded Radius in (mm)	Rolling Circ. in (mm)	Gross Footprint Area in ² (cm ²)	Weight lbs (kg)	Tread Depth in (mm)
5.00-15SL	4T1335	Traction Implement	I-3	4	36 (2.5)	30 (50)	965 (440)	3.00	5.2 (132)	25.6 (650)	11.8 (300)	75 (1,905)	32 (206)	16 (7)	15/32 (12)
5.90-15SL	4T1353	Traction Implement	I-3	4	36 (2.5)	30 (50)	1,140 (520)	4.50	6.3 (160)	26.7 (678)	12.4 (315)	80 (2,032)	45 (290)	17 (8)	15/32 (12)
6.70-15SL TT	4TG267	Sure Grip Traction	I-3	4	32 (2.2)	30 (50)	1,280 (580)	4.50	7.4 (188)	28.8 (732)	13.1 (333)	84 (2,134)	52 (335)	20 (9)	16/32 (13)
7.50-16SL	4TG3B2	Sure Grip Traction	I-3	4	28 (1.9)	30 (50)	1,650 (750)	5.50	8.3 (211)	31.5 (800)	14.1 (358)	90 (2,286)	72 (465)	32 (14.5)	17/32 (13.5)
7.50-18SL TT	4TG2BA	Sure Grip Traction	I-3	4	28 (1.9)	30 (50)	1,710 (775)	5.50	7.8 (198)	33.5 (851)	15.1 (384)	96 (2,438)	73 (471)	34 (15.5)	17/32 (13.5)
7.50-20SL TT	4TG203	Sure Grip Traction	I-3	4	28 (1.9)	30 (50)	1,760 (800)	5.50	7.8 (198)	35.1 (892)	15.9 (404)	103 (2,616)	73 (471)	35 (16)	17/32 (13.5)
7.60-15SL	4TG336	Sure Grip Traction	I-3	6	40 (2.8)	30 (50)	1,760 (800)	6.00	7.8 (198)	29.6 (752)	13.6 (345)	88 (2,235)	61 (394)	28 (13)	16/32 (13)
7.60-15SL	4TG338	Sure Grip Traction	I-3	10	64 (4.4)	30 (50)	2,400 (1,090)	6.00	7.8 (198)	29.6 (752)	13.6 (345)	88 (2,235)	61 (394)	29 (13)	16/32 (13)
12.5/80-18	46W39N	Contractor	I-3	6	28 (1.9)	25 (40)	3,420 (1,550)	9.00	11.7 (297)	37.6 (955)	17.1 (434)	112 (2,845)	131 (845)	75 (34)	31/32 (24.5)
12.5/80-18	4GL5J9	Sure Grip Lug	I-3	14	62 (4.3)	30 (50)	6,600 (3,000)	9.00	12.0 (305)	39.0 (991)	17.3 (439)	119 (3,023)	145 (936)	102 (46)	31/32 (25)
12.5L-15SL	4TG306	Sure Grip Traction	I-3	6	28 (1.9)	30 (50)	2,540 (1,150)	10.00	12.0 (305)	33.3 (846)	14.8 (376)	94 (2,388)	110 (710)	50 (23)	22/32 (17.5)
12.5L-15SL	4TG305	Sure Grip Traction	I-3	12	52 (3.6)	30 (50)	3,860 (1,750)	10.00	12.0 (305)	33.3 (846)	14.8 (376)	94 (2,388)	110 (710)	57 (26)	22/32 (17.5)
16.5L-16.1SL	4TG327	Sure Grip Traction	I-3	6	24 (1.7)	30 (50)	3,960 (1,795)	14.00	16.0 (406)	40.9 (1,039)	17.7 (450)	113 (2,870)	199 (710)	101 (46)	26/32 (20.5)
21.5L-16.1SL	4TG3M3	Sure Grip Traction	I-3	8	24 (1.7)	30 (50)	6,000 (2,720)	18.00	21.6 (549)	43.6 (1,107)	18.6 (472)	121 (3,073)	306 (1,974)	218 (99)	32/32 (25)
21.5L-16.1SL	4TG362	Sure Grip Traction	I-3	14	36 (2.5)	30 (50)	7,850 (3,560)	18.00	21.6 (549)	43.6 (1,107)	18.6 (472)	121 (3,073)	306 (1,974)	236 (107)	32/32 (25)
21.5L-16.1SL	4TG3W3	Sure Grip Traction	I-3	12	28 (1.9)	30 (50)	6,600 (2,995)	18.00	21.6 (549)	43.6 (1,107)	18.6 (472)	121 (3,073)	306 (1,974)	230 (104)	32/32 (25)

TT - Tube Type

Bias Backhoe



Contractor



Contractor II



TI422



TRACTION IMPLEMENT

Titan Contractor (I-3)

- An implement tire specially designed for high traction applications
- Frequently used on the front of backhoes, this tire is available in 10-ply construction

Titan Contractor II (I-3)

- A more robust design for use on the front of large backhoes

Titan TI422 (I-3)

- Designed for low horsepower traction requirements, the Traction Implement offers good roadability and excellent durability

Titan Traction Implement (I-3)

- Designed for low horsepower traction requirements, the Traction Implement offers good roadability and excellent durability

Tire Size	TL/TT	Catalog Number	Design	Industry Code	Ply Rating	Inflation Pressure PSI (bar)	Max Speed mph (km/h)	Max Load lbs (kg)	Rim* Width Code	Section Width in (mm)	Overall Diameter in (mm)	Static Loaded Radius in (mm)	Rolling Circ. in (mm)	Gross Footprint Area in ² (cm ²)	Weight lbs (kg)	Tread Depth in (mm)
7.50-20SL	TL	422303	Traction Implement	I-3	4	28 (1.9)	30 (50)	1,760 (800)	5.50	8.1 (206)	34.9 (886)	15.9 (404)	104 (2,642)	---	38 (17)	17/32 (13.5)
7.50-24S	TT	422204	Traction Implement	I-3	4	28 (1.9)	30 (50)	1,870 (850)	7.00	8.7 (221)	38.9 (988)	17.9 (455)	115 (2,921)	---	41 (18.5)	17/32 (13.5)
10.5/80-18	TL	46W3X8	Contractor	I-3	6	33 (3.3)	25 (40)	2,830 (1,285)	9.00	10.8 (274)	35.7 (907)	16.5 (419)	109 (2,769)	---	72 (33)	29/32 (23)
10.5/80-18	TL	46W3J8	Contractor	I-3	10	54 (3.7)	25 (40)	3,840 (1,740)	9.00	10.8 (274)	35.7 (907)	16.5 (419)	109 (2,769)	---	73 (33)	29/32 (23)
12.5/80-18	TL	46W3J9	Contractor	I-3	10	46 (3.2)	25 (40)	4,710 (2,140)	9.00	12.0 (305)	38.8 (986)	17.4 (442)	114 (2,896)	---	104 (47)	31/32 (25)
12.5/80-18	TL	4223J9	TI422	I-3	10	46 (3.2)	25 (40)	4,710 (2,140)	9.00	12.0 (305)	38.8 (986)	17.4 (442)	114 (2,896)	---	92 (42)	34/32 (27)
12.5/80-18	TL	42E3J9	Contractor II	I-3	10	46 (3.2)	25 (40)	4,710 (2,140)	9.00	12.3 (312)	38.4 (975)	17.1 (434)	114 (2,896)	---	94 (42.5)	32/32 (25)
12.5/80-18	TL	42E3T7	Contractor II	I-3	12	56 (3.9)	25 (40)	4,710 (2,140)	9.00	12.3 (312)	38.4 (975)	17.1 (434)	114 (2,896)	---	94 (42.5)	32/32 (25)
13.50-16.1SL	TL	499505	Traction Implement	I-3	6	24 (1.7)	30 (50)	3,520 (1,600)	11.00	13.5 (343)	40.8 (1,036)	17.8 (452)	120 (3,048)	---	85 (38.5)	23/32 (18)
16.5L-16.1SL	TL	4223M2	TI422	I-3	6	24 (1.7)	30 (50)	3,960 (1,800)	14.00	16.5 (419)	40.0 (1,016)	17.7 (450)	117 (2,972)	---	98 (44.5)	26/32 (21)
16.5L-16.1SL	TL	4223W6	TI422	I-3	10	36 (2.5)	30 (50)	5,200 (2,360)	14.00	16.5 (419)	40.0 (1,016)	17.7 (450)	117 (2,972)	---	109 (49.5)	26/32 (21)
21.5L-16.1SL	TL	4223M3	TI422	I-3	8	24 (1.7)	30 (50)	6,000 (2,720)	18.00	20.3 (516)	44.6 (1,133)	19.6 (498)	132 (3,353)	---	156 (71)	35/32 (28)
LSW280/70D20	TL	G6W3J8	Contractor	I-3	10	54 (3.7)	25 (40)	3,840 (1,740)	9.00	10.8 (274)	35.6 (904)	16.2 (412)	108 (2,743)	---	73 (33)	29/32 (23)
LSW320/75D20	TL	G6W3J9	Contractor	I-3	10	46 (3.2)	25 (40)	4,710 (2,136)	9.00	12.1 (307)	38.6 (980)	17.3 (439)	115 (2,920)	---	99 (45)	31/32 (25)
LSW320/75D20	TL	G2E3T7	Contractor II	I-3	12	56 (3.9)	25 (40)	5,360 (2,430)	9.00	12.0E (305)	39.1E (993)	18.0E (457)	117E (2,972)	---	120E (54.5)	32/32 (25)
LSW320/75D20	TL	G2E5T7	Contractor II	I-3	14	64 (4.4)	25 (40)	5,840 (2,650)	9.00	12.0E (305)	39.1E (993)	18.0E (457)	117E (2,972)	---	120E (54.5)	32/32 (25)

E - Estimated

* See Approved Rim Contours section



IT323 SS



Sure Grip Lug

Goodyear IT323 SS

- Heavier under tread
- Sidewall scuff rib
- Wear pad design for better wear

Goodyear Sure Grip Lug

- Directional design for excellent traction
- For use in soft soil operations where traction and flotation are required



Industrial Xtra Grip

Goodyear Industrial Xtra Grip SS

Tire Size	Catalog Number	Design	Ply Rating	Inflation Pressure PSI (bar)	Max Speed mph (km/h)	Max Load lbs (kg)	Rim Width Code	Section Width in (mm)	Overall Diameter in (mm)	Static Loaded Radius in (mm)	Rolling Circ. in (mm)	Gross Footprint Area in ² (cm ²)	Weight lbs (kg)	Tread Depth in (mm)
5.7-8NHS	4DG330	Industrial Xtra Grip	8	50 (3.4)	5 (10)	710 (320)	4.50	5.8 (147)	18.6 (472)	8.6 (218)	55.5 (1,410)	13 (84)	12 (5)	---
25x8.50-14NHS	4GL379	Sure Grip Lug	6	32 (2.2)	5 (10)	1,640 (745)	7.00	8.4 (213)	25.4 (645)	11.5 (292)	72.2 (1,834)	57 (368)	30 (14)	18/32 (14)
23x8.50-12NHS	4323C3	IT323	4	35 (2.4)	5 (10)	1,470 (665)	7.00	8.6 (218)	22.8 (579)	10.0 (254)	67.0 (1,702)	48 (310)	25 (11)	16/32 (13)
27x8.50-15NHS	4GL3J3GY	Sure Grip Lug	4	35 (2.4)	5 (10)	1,840 (835)	7.00	8.5 (216)	27.2 (691)	12.2 (310)	79.0 (2,007)	65 (419)	31 (14)	18/32 (14)
27x8.50-15NHS	4GL339GY	Sure Grip Lug	6	45 (3.1)	5 (10)	2,480 (1,125)	7.00	8.5 (216)	27.2 (691)	12.2 (310)	79.0 (2,007)	65 (419)	36 (16)	18/32 (14)
27x8.50-15NHS	432339	IT323	6	45 (3.1)	5 (10)	2,480 (1,125)	7.00	8.8 (224)	27.2 (691)	12.2 (310)	79.0 (2,007)	65 (419)	37 (17)	18/32 (14)
27x10.50-15NHS	4233L6	IT323	4	30 (2.1)	5 (10)	2,085 (945)	8.50	10.0 (254)	27.2 (691)	12.7 (323)	82.3 (2,090)	80 (516)	43 (20)	20/32 (16)
27x10.50-15NHS	4323H7	IT323	6	45 (3.1)	5 (10)	2,610 (1,185)	8.50	10.0 (254)	27.2 (691)	12.7 (323)	82.3 (2,090)	80 (516)	44 (20)	20/32 (16)
27x10.50-15NHS	4GL3H7	Sure Grip Lug	6	45 (3.1)	5 (10)	2,610 (1,185)	8.50	10.3 (262)	27.2 (691)	12.7 (323)	82.0 (2,083)	80 (516)	37 (17)	18/32 (14)
10-16.5NHS	4GL3C8	Sure Grip Lug	6	45 (3.1)	5 (10)	3,500 (1,590)	8.25	10.9 (277)	30.4 (772)	14.1 (358)	91.0 (2,311)	83 (535)	51 (23)	21/32 (17)
10-16.5 NHS	4GL3D1	Sure Grip Lug	8	60 (4.1)	5 (10)	4,140 (1,880)	8.25	10.9 (277)	30.4 (772)	14.1 (358)	91.0 (2,311)	83 (535)	53 (24)	21/32 (17)
10-16.5NHS	4323D1GY	IT323	8	60 (4.1)	5 (10)	4,140 (1,880)	8.25	10.8 (274)	30.6 (777)	14.2 (361)	92.4 (2,347)	83 (535)	58 (26)	25/32 (20)
31x15.50-15NHS	4323L8	IT323	8	35 (2.4)	5 (10)	4,480 (2,030)	12.00	15.7 (399)	31.5 (800)	13.9 (353)	90.0 (2,286)	110 (710)	83 (38)	25/32 (20)
12-16.5NHS	4GL3E8	Sure Grip Lug	8	50 (3.4)	5 (10)	4,810 (2,180)	9.75	12.6 (320)	32.7 (831)	14.8 (376)	98.0 (2,489)	110 (710)	72 (33)	23/32 (18)
12-16.5NHS	4GL3J7	Sure Grip Lug	10	65 (4.5)	5 (10)	5,600 (2,540)	9.75	12.6 (320)	32.7 (831)	14.8 (376)	98.0 (2,489)	110 (710)	74 (34)	23/32 (18)
12-16.5NHS	4323J7GY	IT323	10	65 (4.5)	5 (10)	5,600 (2,540)	9.75	12.7 (323)	32.9 (836)	14.9 (378)	99.0 (2,515)	110 (710)	77 (35)	26/32 (21)
15-19.5NHS	4GL336	Sure Grip Lug	12	60 (4.1)	5 (10)	9,190 (4,170)	11.75	15.9 (404)	40.1 (1,019)	18.0 (457)	117.0 (2,972)	163 (1052)	136 (62)	26/32 (21)
15-19.5NHS	4323H9	IT323	8	40 (2.8)	5 (10)	7,250 (3,290)	11.75	15.9 (404)	40.1 (1,019)	18.0 (457)	117.0 (2,972)	163 (1,052)	121 (55)	30/32 (24)
15-19.5NHS#	4GL3H9	Sure Grip Lug	8	40 (2.8)	5 (10)	7,250 (3,290)	11.75	15.9 (404)	40.1 (1,019)	18.0 (457)	117.0 (2,972)	163 (1,052)	121 (55)	26/32 (21)

Minimum Order Qty.

Bias Skid Steer



Contractor FWD SS



Trac Loader SS



Trac Loader Chevron SS



HD2000 SS



HD2000 II SS



Soft Turf

Titan Contractor FWD SS

- Excellent traction and wear are the benefits of the broad, curved lugs
- High strength construction gives it exceptional durability

Titan Trac Loader SS

- The tire preferred by major manufacturers of unloaders and skid steer equipment
- Center lug design adds extra traction

Titan Trac Loader Chevron SS

- Features a chevron tread pattern with nylon fabric construction
- Intended for skid steer use

Titan HD2000 SS

- Engineered with HD sidewalls to protect against abrasions, tears and punctures
- Improved dual tapered step lug wear and extended life

Titan HD2000 II SS

- Titan's premium conventional skid steer tire with deeper tread depth, premium compound, larger tread lugs, heavier sidewall and larger rim guard

Titan Soft Turf

- Designed for low ground pressure use
- Ideal for fine lawn maintenance and can also be used for industrial applications
- Less Aggressive to minimize turf damage

Tire Size	Catalog Number	Design	Ply Rating	Inflation Pressure PSI (bar)	Max Speed mph (km/h)	Max Load lbs (kg)	Rim Width Code	Section Width in (mm)	Overall Diameter in (mm)	Static Loaded Radius in (mm)	Rolling Circ. in (mm)	Gross Footprint Area in ² (cm ²)	Weight lbs (kg)	Tread Depth in (mm)
5.70-12NHS	4123C2	Trac Loader Chevron	4	60 (4.1)	5 (10)	1,450 (660)	4.50	5.7 (145)	22.4 (569)	10.3 (262)	67 (1,702)	---	19 (9)	18/32 (14)
7.00-15SS	4123C5	Trac Loader Chevron	6	60 (4.1)	5 (10)	3,180 (1,440)	5.50	8.0 (203)	29.9 (759)	13.5 (343)	88 (2,235)	---	37 (17)	18/32 (14)
8.25-15NHS	4127K5	Trac Loader Chevron	6	50 (3.4)	5 (10)	3,860 (1,750)	6.00	9.4 (239)	33.2 (843)	14.9 (378)	98 (2,489)	---	53 (24)	18/32 (14)
10-16.5NHS	4123C8	Trac Loader	6	45 (3.1)	5 (10)	3,500 (1,590)	8.25	10.9 (277)	30.3 (770)	13.5 (343)	90 (2,286)	---	46 (21)	19/32 (15)
10-16.5NHS	4393D1	HD2000	8	60 (4.1)	5 (10)	4,140 (1,880)	8.25	10.3 (262)	30.6 (777)	14.3 (363)	92 (2,337)	---	58 (26)	21/32 (17)
10-16.5NHS	49E3D1	HD2000II	8	60 (4.1)	5 (10)	4,140 (1,880)	8.25	10.5 (267)	30.3 (770)	14.1 (358)	91 (2,311)	---	58 (26)	24/32 (19)
10-16.5NHS	4393D1TYL	HD2000*	8	60 (4.1)	5 (10)	4,140 (1,880)	8.25	10.3 (262)	30.6 (777)	14.3 (363)	92 (2,337)	---	74 (33.5)	21/32 (17)
10-16.5NHS	49E3D1TYL	HD2000II*	8	60 (4.1)	5 (10)	4,140 (1,880)	8.25	10.5 (267)	30.3 (770)	14.1 (358)	91 (2,311)	---	83 (37.5)	24/32 (19)
12-16.5NHS	4393C9	HD2000	6	40 (2.8)	5 (10)	4,220 (1,915)	9.75	12.8 (325)	32.7 (831)	15.3 (389)	99 (2,515)	---	75 (34)	23/32 (18)
12-16.5NHS	4123C9	Trac Loader	6	40 (2.8)	5 (10)	4,220 (1,915)	9.75	12.1 (307)	33.6 (853)	15.1 (384)	101 (2,565)	---	68 (31)	23/32 (18)
12-16.5NHS	4123D2	Trac Loader	8	50 (3.4)	5 (10)	4,810 (2,180)	9.75	12.2 (310)	33.6 (853)	15.1 (384)	101 (2,565)	---	72 (33)	23/32 (18)
12-16.5NHS	46C3J7	Contractor FWD	10	65 (4.5)	5 (10)	5,600 (2,540)	9.75	11.8 (300)	33.1 (841)	14.9 (378)	98 (2,489)	---	77 (35)	23/32 (18)
12-16.5NHS	4393J7	HD2000	10	65 (4.5)	5 (10)	5,600 (2,540)	9.75	12.8 (325)	32.7 (831)	15.3 (389)	99 (2,515)	---	77 (35)	23/32 (18)
12-16.5NHS	4393J7TYL	HD2000 *	10	65 (4.5)	5 (10)	5,600 (2,540)	9.75	12.2 (310)	32.7 (831)	15.0 (381)	97 (2,464)	---	99 (45)	26/32 (21)
12-16.5NHS	49E3J7	HD2000II	10	65 (4.5)	5 (10)	5,600 (2,540)	9.75	12.2 (310)	32.7 (831)	15.0 (381)	97 (2,464)	---	77 (35)	26/32 (21)
12-16.5NHS	49E3J7TYL	HD2000II *	10	65 (4.5)	5 (10)	5,600 (2,540)	9.75	12.2 (310)	32.7 (831)	15.0 (381)	97 (2,464)	---	77 (35)	26/32 (21)

*w/Tyrelyner

Tire Size	Catalog Number	Design	Ply Rating	Inflation Pressure PSI (bar)	Max Speed mph (km/h)	Max Load lbs (kg)	Rim Width Code	Section Width in (mm)	Overall Diameter in (mm)	Static Loaded Radius in (mm)	Rolling Circ. in (mm)	Gross Footprint Area in ² (cm ²)	Weight lbs (kg)	Tread Depth in (mm)
12-16.5NHS	4303J7	Soft Turf	10	65 (4.5)	5 (10)	5,600 (2,540)	9.75	14.2 (361)	32.9 (836)	14.7 (373)	98 (2,489)	---	68 (31)	10/32 (8)
12-16.5NHS	4123J7	Trac Loader	10	65 (4.5)	5 (10)	5,600 (2,540)	9.75	12.2 (310)	33.6 (853)	15.1 (384)	101 (2,565)	---	69 (31)	23/32 (18)
12-16.5NHS	4393J8	HD2000	12	80 (5.5)	5 (10)	6,320 (2,865)	9.75	12.8 (325)	32.7 (831)	15.3 (389)	99 (2,515)	---	70 (32)	23/32 (18)
12-16.5NHS	49E3J8#	HD2000II	12	80 (5.5)	5 (10)	6,320 (2,865)	9.75	12.2 (310)	32.7 (831)	15.0 (381)	97 (2,464)	---	78 (35.5)	26/32 (21)
12-16.5NHS	49E34R	HD2000II	14	90 (6.2)	5 (10)	6,780 (3,075)	9.75	12.2 (310)	32.7 (831)	15.0 (381)	97 (2,464)	---	83 (38)	26/32 (21)
14-17.5NHS	412334	Trac Loader	6	30 (2.1)	5 (10)	4,820 (2,185)	10.50	14.0 (356)	36.9 (937)	16.3 (414)	109 (2,769)	---	91 (41)	24/32 (19)
14-17.5NHS	46C3G9	Contractor FWD	10	55 (3.8)	5 (10)	6,850 (3,105)	10.50	13.8 (351)	36.3 (922)	16.3 (414)	108 (2,743)	---	84 (38)	24/32 (19)
14-17.5NHS	439396	HD2000	10	55 (3.8)	5 (10)	6,850 (3,105)	10.50	14.5 (368)	36.3 (922)	16.2 (412)	108 (2,743)	---	94 (43)	24/32 (19)
14-17.5NHS	430396	Soft Turf	10	55 (3.8)	5 (10)	6,850 (3,105)	10.50	15.3 (389)	36.1 (917)	16.0 (406)	106 (2,692)	---	78 (35.5)	10/32 (8)
14-17.5NHS	412396	Trac Loader	10	55 (3.8)	5 (10)	6,850 (3,105)	10.50	14.0 (356)	36.9 (937)	16.3 (414)	109 (2,769)	---	94 (43)	24/32 (19)
14-17.5NHS	439349	HD2000	12	65 (4.5)	5 (10)	7,550 (3,420)	10.50	14.5 (368)	36.3 (922)	16.2 (412)	108 (2,743)	---	102 (46)	24/32 (19)
14-17.5NHS	439384	HD2000	14	80 (5.5)	5 (10)	8,540 (3,875)	10.50	14.5 (368)	36.3 (922)	16.2 (412)	108 (2,743)	---	106 (48)	24/32 (19)
14-17.5NHS	49E384	HD2000II	14	80 (5.5)	5 (10)	8,540 (3,875)	10.50	15.2 (386)	35.7 (907)	16.4 (417)	107 (2,718)	---	121 (55)	26/32 (21)
14-17.5NHS	412384	Trac Loader	14	80 (5.5)	5 (10)	8,540 (3,875)	10.50	14.3 (363)	36.4 (925)	16.4 (417)	107 (2,718)	---	106 (48)	24/32 (19)
15-19.5NHS	412373	Trac Loader	6	30 (2.1)	5 (10)	6,130 (2,780)	11.75	15.5 (394)	40.5 (1,029)	17.9 (455)	117 (2,972)	---	114 (52)	25/32 (20)
15-19.5NHS	46C3H9	Contractor FWD	8	40 (2.8)	5 (10)	7,250 (3,290)	11.75	15.3 (389)	40.1 (1,019)	18 (457)	119 (3,023)	---	113 (51)	26/32 (21)
15-19.5NHS	439336	HD2000	12	60 (4.1)	5 (10)	9,190 (4,170)	11.75	15.7 (399)	40.5 (1,029)	19.2 (488)	123 (3,124)	---	136 (62)	26/32 (21)
15-19.5NHS	412336	Trac Loader	12	60 (4.1)	5 (10)	9,190 (4,170)	11.75	15.5 (394)	40.5 (1,029)	17.9 (455)	117 (2,972)	---	136 (62)	25/32 (20)
15-19.5NHS	439636	HD2000	16	85 (5.9)	5 (10)	11,270 (5,100)	11.75	15.7 (399)	40.5 (1,029)	19.2 (488)	123 (3,124)	---	150 (68)	26/32 (21)
18x8.50-10NHS	4123U1	Trac Loader	4	22 (1.5)	5 (10)	830 (375)	7.00	7.5 (191)	17.7 (450)	8.1 (206)	53 (1,346)	38 (245)	18 (8)	16/32 (13)
20x8.00-10NHS	49E3W8	HD2000II	4	40 (2.8)	5 (10)	1,210 (550)	6.00	8.2 (208)	19.3 (490)	8.8 (224)	57 (1,448)	---	24 (11)	15/32 (12)
23x8.50-12NHS	4123C3	Trac Loader	4	35 (2.4)	5 (10)	1,470 (665)	7.00	8.3 (211)	23.0 (584)	10.2 (259)	68 (1,727)	---	27 (12)	14/32 (11)
23x8.50-12NHS	4393G8	HD2000	6	50 (3.4)	5 (10)	1,810 (820)	7.00	8.7 (221)	23.5 (597)	11.0 (279)	71 (1,803)	---	27 (12)	14/32 (11)
23x8.50-12NHS	4123G8	Trac Loader	6	50 (3.4)	5 (10)	1,810 (820)	7.00	8.3 (211)	23.0 (584)	10.2 (259)	68 (1,727)	---	27 (12)	14/32 (11)
23x8.50-14NHS	412388	Trac Loader	4	35 (2.4)	5 (10)	1,490 (647)	7.00	7.8 (198)	23.8 (605)	10.7 (272)	71 (1,803)	---	25 (11)	14/32 (11)
25x8.50-14NHS	412379	Trac Loader	6	50 (3.4)	5 (10)	2,000 (905)	7.00	8.4 (213)	25.9 (658)	11.8 (300)	79 (2,007)	---	30 (13.5)	17/32 (13)
26x12.00-12NHS	412361	Trac Loader	4	20 (1.4)	5 (10)	1,780 (805)	10.50	12.2 (310)	25.5 (648)	11.3 (287)	77 (1,956)	84 (542)	40 (18)	16/32 (13)
27x8.50-15NHS	4123C6	Trac Loader	4	30 (2.1)	5 (10)	1,940 (880)	7.00	8.8 (224)	27.0 (686)	12.1 (307)	81 (2,057)	---	39 (18)	17/32 (13)
27x8.50-15NHS	412339	Trac Loader	6	45 (3.1)	5 (10)	2,480 (1,120)	7.00	8.8 (224)	27.0 (686)	12.1 (307)	81 (2,057)	---	39 (18)	17/32 (13)
27x8.50-15NHS	439377	HD2000	8	60 (4.1)	5 (10)	2,890 (1,340)	7.00	8.6 (218)	26.8 (681)	12.5 (318)	81 (2,057)	---	39 (18)	15/32 (12)
27x10.50-15NHS	4123H7	Trac Loader	6	45 (3.1)	5 (10)	2,610 (1,180)	8.50	11.0 (279)	27.5 (699)	12.3 (312)	82 (2,083)	---	39 (18)	17/32 (13)

*w/Tyrelynor

Minimum Order Qty.

Bias Skid Steer

Tire Size	Catalog Number	Design	Ply Rating	Inflation Pressure PSI (bar)	Max Speed mph (km/h)	Max Load lbs (kg)	Rim Width Code	Section Width in (mm)	Overall Diameter in (mm)	Static Loaded Radius in (mm)	Rolling Circ. in (mm)	Gross Footprint Area in ² (cm ²)	Weight lbs (kg)	Tread Depth in (mm)
27x10.50-15NHS	439378	HD2000	8	60 (4.1)	5 (10)	3,100 (1,410)	8.50	10.2 (249)	27.1 (688)	12.8 (325)	82 (2,083)	---	47 (21)	15/32 (12)
LSW10-19.5NHS	G9E3D1	HD2000II	8	60 (4.1)	5 (10)	4,140 (1,880)	8.25	10.4 (264)	30.6 (777)	13.9 (353)	93 (2,362)	---	59 (27)	24/32 (19)
LSW12-19.5NHS	G9E3J7	HD2000II	10	65 (4.5)	5 (10)	5,600 (2,540)	9.75	12.1 (307)	32.7 (831)	14.7 (373)	98 (2,489)	---	79 (36)	24/32 (19)
27x12.50-15NHS	4122N7	Trac Loader	4	25 (1.8)	5 (10)	2,340 (1,061)	10.00	11.2 (285)	28.2 (716)	12.6 (320)	84 (2,126)	105 (677)	45 (20.5)	17/32 (13)
28x8.50-15NHS	4123R3	Trac Loader	6	45 (3.1)	5 (10)	2,880 (1,310)	7.00	8.4 (213)	28.0 (711)	12.8 (325)	83 (2,108)	---	29 (13)	17/32 (13)
30.5x12.50-16.5NHS	439381	HD2000	8	45 (3.1)	5 (10)	3,840 (1,740)	9.75	12.5 (318)	30.8 (782)	14.0 (356)	91 (2,311)	---	74 (33.5)	21/32 (17)
31x15.50-16.5NHS	49E3L8	HD2000II	8	35 (2.4)	5 (10)	4,480 (2,030)	12.00	15.5 (394)	31.0 (787)	14.1 (358)	92 (2,337)	---	87 (39.5)	24/32 (19)
31x15.50-16.5NHS	49E3L9	HD2000II	12	60 (4.1)	5 (10)	6,150 (2,790)	12.00	15.5 (394)	31.0 (787)	14.1 (358)	92 (2,337)	---	90 (41)	24/32 (19)
33x14.50-16.5NHS	4123J9	Trac Loader	8	40 (2.8)	5 (10)	4,690 (2,130)	12.00	14.5 (368)	33.0 (838)	14.9 (378)	98 (2,489)	---	72 (32.5)	23/32 (18)
33x15.50-16.5NHS	49E3X3	HD2000II	12	60 (4.1)	5 (10)	6,835 (3,100)	12.00	15.5 (394)	33.0 (838)	15.0 (381)	98 (2,489)	---	110 (50)	24/32 (19)
33x15.50-16.5NHS	49E3R9	HD2000II	14	70 (4.8)	5 (10)	7,480 (3,390)	12.00	15.5 (394)	33.0 (838)	15.0 (381)	98 (2,489)	---	110 (50)	24/32 (19)
43x16.00-20NHS	4123A5	Trac Loader	4	20 (1.4)	5 (10)	4,540 (2,060)	14.00	16.0 (406)	43.5 (1,105)	19.3 (490)	129 (3,277)	---	135 (61)	26/32 (21)



Titan Ultimate

- Extra long life with up to twice the tread depth of conventional skid steer tires.
- Superior damage resistance due to extra heavy sidewall and large rim guard.
- Superior traction from high void-to-lug ratio.
- Lowest possible cost per hour delivered by specialty compound and industry leading tread depth.



Titan H/E

- The H/E is Titan's premium deep tread skid steer tire, designed for use in severe applications such as concrete planing, asphalt recycling, demolition areas, quarries, glass plants and scrap yards

Tire Size	Catalog Number	Design	Ply Rating	Inflation Pressure PSI (bar)	Max Speed mph (km/h)	Max Load lbs (kg)	Rim Width Code	Section Width in (mm)	Overall Diameter in (mm)	Static Loaded Radius in (mm)	Rolling Circ. in (mm)	Gross Footprint Area in ² (cm ²)	Weight lbs (kg)	Tread Depth in (mm)
10-16.5NHS	49U3D1	Ultimate	8	60 (4.1)	5 (10)	4,140 (1,880)	8.25	10.7 (272)	30.1 (765)	13.7 (348)	91 (2,311)	---	72 (33)	42/32 (33)
10-16.5NHS	43H3R8	H/E	10	75 (5.2)	5 (10)	4,710 (2,135)	8.25	10.4 (264)	30.6 (777)	13.7 (348)	89 (2,261)	---	79 (36)	44/32 (35)
12-16.5NHS	49U3J7	Ultimate	10	65 (4.5)	5 (10)	5,600 (2,540)	9.75	12.1 (307)	32.7 (831)	14.9 (378)	98 (2,489)	---	94 (43)	44/32 (35)
12-16.5NHS	43H34R	H/E	14	90 (6.2)	5 (10)	6,780 (3,075)	9.75	12.0 (305)	32.7 (831)	15.0 (381)	97 (2,464)	---	106 (48)	44/32 (35)
14-17.5NHS	43H384	H/E	14	80 (5.5)	5 (10)	8,540 (3,875)	10.50	14.1 (358)	36.6 (930)	17.0 (432)	110 (2,794)	---	141 (64)	47/32 (37)
14-17.5NHS	49U384	Ultimate	14	80 (5.5)	5 (10)	8,540 (3,875)	10.50	15.2 (386)	35.7 (907)	16.4 (417)	107 (2,718)	---	148 (67)	44/32 (35)
33x15.50-16.5NHS	43H3X3	H/E	12	60 (4.1)	5 (10)	6,835 (3,100)	12.00	14.5 (368)	33.0 (838)	14.7 (373)	99 (2,515)	135 (871)	120 (54.5)	48/32 (38)



Titan Grizz LSWG9A

- Premium LSW skid steer tire with all the features of the HD2000 II, plus run flat capability
- LSW assemblies reduce bounce and lope, and improve lateral stability

Tire Size	Catalog Number	Ply Rating	Inflation Pressure PSI (bar)	Max Speed mph (km/h)	Max Load lbs (kg)	Rim Width Code	Section Width in (mm)	Overall Diameter in (mm)	Static Loaded Radius in (mm)	Rolling Circ. in (mm)	Gross Footprint Area in ² (cm ²)	Weight lbs (kg)	Tread Depth in (mm)
LSW265-521NHS	G9A3D1	10	60 (4.1)	5 (10)	4,720 (2,140)	210	10.2 (259)	30.6 (777)	14.2 (361)	92 (2,337)	---	56 (25.5)	24/32 (19)
LSW305-546NHS	G9A3M1	10	65 (4.5)	5 (10)	5,600 (2,540)	248	12.1 (307)	32.8 (833)	15.1 (384)	98 (2,489)	---	73 (33)	24/32 (19)

Bias Skid Steer



Smooth Industrial



Compactor

Goodyear Smooth Industrial Goodyear Compactor

- Designed for unique demands of air drills
- Sidewall scuff rib
- Wear pad design for better wear

Tire Size	Catalog Number	Design	TL/TT	Ply Rating	Inflation Pressure PSI (bar)	Max Speed mph (km/h)	Max Load lbs (kg)	Rim Width Code	Overall Diameter in (mm)	Section Width in (mm)	Static Loaded Radius in (mm)	Rolling Circ. in (mm)	Gross Footprint Area in ² (cm ²)	Weight lbs (kg)	Tread Depth in (mm)
6.00-16NHS	3SN278	Smooth Industrial	TT	10	75 (5.2)	20 (30)	2,230 (1,010)	6.00	29.0 (737)	7.3 (185)	13.8 (351)	---	85.1 (2,162)	30.4 (196)	8/32 (6)*
8.5/90-15K	3SC3A2	Compactor	TL	6	50 (3.4)	5 (10)	3,900 (1,770)	5.50F	30.6 (777)	8.5 (216)	13.8 (351)	---	88.0 (2,235)	76.0 (490)	0*
7.50-15NHS	3SC252	Compactor	TT	12	110 (7.6)	5 (10)	5,860 (2,660)	6.50	31.0 (787)	8.4 (213)	14.2 (361)	---	91.0 (2,311)	64.0 (413)	0*
7.50-15NHS	3SC2E1	Compactor	TT	14	125 (8.6)	5 (10)	6,300 (2,860)	6.50	31.0 (787)	8.4 (213)	14.2 (361)	---	91.0 (2,311)	64.0 (413)	0*

*Tire rim fitment for these tires are not interchangeable. The 15K tire will only fit on a 5° drop center rim. The NHS tire is designed to fit on a 5° flat base rim. The 8.5/90-15K size designation was established to advise of this distinction.



Titan Road Roller/Road Roller II

- Constructed of superior heat resistant nylon fabric plies to promote heat dissipation
- Designed for maximum life, this tire is frequently the tire of choice for industrial compactor applications

Tire Size	Catalog Number*	Design	TL/TT	Ply Rating	Inflation Pressure PSI (bar)	Max Speed mph (km/h)	Max Load lbs (kg)	Rim Width Code	Overall Diameter in (mm)	Section Width in (mm)	Static Loaded Radius in (mm)	Rolling Circ. in (mm)	Gross Footprint Area in ² (cm ²)	Weight lbs (kg)	Tread Depth in (mm)
7.50-15NHS	3GR256F	Road Roller II	TT	6	55 (3.8)	5 (10)	3,900 (1,770)	6.00	30.8 (782)	8.1 (206)	14.1 (358)	92 (2,337)	---	46 (2.1)	0*
7.50-15NHS	3GR252F	Road Roller II	TT	12	110 (7.6)	5 (10)	5,860 (2,660)	6.00	30.8 (782)	8.1 (206)	14.1 (358)	92 (2,337)	---	56 (25.5)	0*
7.50-15NHS	3GR2E1F	Road Roller II	TT	14	125 (8.6)	5 (10)	6,300 (2,860)	6.00	30.8 (782)	8.1 (206)	14.1 (358)	92 (2,337)	---	56 (25.5)	0*
8.5/90-15K	3GR3A2	Road Roller II	TL	6	50 (3.4)	5 (10)	3,900 (1,770)	5.50F	30.9 (785)	8.1 (206)	13.7 (348)	90 (2,286)	---	47 (21.5)	0*
9.00-20NHS	38R222F	Road Roller	TT	12	90 (6.2)	5 (10)	8,950 (4,060)	7.00	39.8 (1,011)	10.2 (259)	18.0 (457)	117 (2,972)	---	112 (51)	0
11.00-20NHS	38R283F	Road Roller	TT	18	120 (8.3)	5 (10)	13,000 (5,900)	8.00	41.7 (1,059)	12.1 (307)	18.8 (478)	122 (3,099)	---	185 (84)	0

*Tire rim fitment for these tires are not interchangeable. The 8.5/90-15K tire will only fit on a 5° drop center rim. The NHS tire is designed to fit on a 5° flat base rim. The 8.5/90-15K size designation was established to advise of this distinction.

*Ending in F indicates flap included

Load and Inflation Tables

20.5-25 Articulated Truck Usage Chart

For Standard Earthmover Service: < 2.5 mi, < 30 mph

Manufacturer	Model	Payload	Front Minimum Ply Rating	Front Minimum Inflation	Middle Minimum Ply Rating	Middle Minimum Inflation	Rear Minimum Ply Rating	Rear Minimum Inflation
		Tons		Psi		Psi		Psi
Bell	B20B	20	16	35	20	40	20	40
Bell	B20D 6x4	18	16	30	24	45	20	45
Bell	B20D 6x6	18	16	30	24	50	24	45
Caterpillar	D250B	25	24	50	CT	CT	CT	CT
Caterpillar	D250D	25	24	45	CT	CT	CT	CT
Komatsu	HA250-1	25	CT	CT	CT	CT	CT	CT
Moxy	MT30 LHS	30	CT	CT	CT	CT	CT	CT
Terex	2364	23	24	50	24	50	24	45
Terex	2366	23	24	50	24	50	24	45
Terex	2566B	25	CT	CT	CT	CT	24	50
Terex	2566C	25	CT	CT	CT	CT	24	55
Volvo	A20 6X4	20	-	-	20	45	20	45
Volvo	A20 6x6	20	-	-	20	45	20	45
Volvo	A20C 6X6	20	20	40	20	45	20	45
Volvo	A25 6X4	25	20	40	CT	CT	CT	CT
Volvo	A25	25	20	45	CT	CT	CT	CT
Volvo	A25B	25	20	40	CT	CT	CT	CT

23.5-25 Articulated Truck Usage Chart

For Standard Earthmover Service: < 2.5 mi, < 30 mph

Manufacturer	Model	Payload	Front Minimum Ply Rating	Front Minimum Inflation	Middle Minimum Ply Rating	Middle Minimum Inflation	Rear Minimum Ply Rating	Rear Minimum Inflation
		Tons		Psi		Psi		Psi
Bell	B25B	25	20	35	20	35	20	35
Bell	B25D	26	20	35	20	40	20	40
Bell	B25E	27	16	30	CT	CT	CT	CT
Bell	B30B	30	CT	CT	CT	CT	CT	CT
Bell	B30D	30	20	35	CT	CT	CT	CT
Bell	B30E	31	20	35	CT	CT	CT	CT
Caterpillar	D20D	20	CT	CT	12	25	CT	CT
Caterpillar	D250B	25	20	35	20	40	20	40
Caterpillar	D250D	25	16	30	20	40	20	40
Caterpillar	D250E	25	20	40	CT	CT	CT	CT
Caterpillar	D300B	30	20	40	CT	CT	CT	CT
Caterpillar	D300D	30	20	40	CT	CT	CT	CT
Caterpillar	D300E	30	20	40	CT	CT	CT	CT
Caterpillar	D350C	35	CT	CT	CT	CT	CT	CT
Caterpillar	725	25	20	40	CT	CT	CT	CT
Caterpillar	725	26	CT	CT	CT	CT	CT	CT
Caterpillar	725C	26	CT	CT	CT	CT	CT	CT
Caterpillar	730	30	CT	CT	CT	CT	CT	CT
Caterpillar	730	31	CT	CT	CT	CT	CT	CT
Caterpillar	730 EJ	31	CT	CT	CT	CT	CT	CT
Caterpillar	730C	31	CT	CT	CT	CT	CT	CT
Caterpillar	730C EJ	31	CT	CT	CT	CT	CT	CT

Pressure and ply recommendations based on normal quarry operations with standard equipment. For different applications, or modified equipment, please contact OTR Field Engineering for a specific recommendation. Tire damage or failure caused by improper load, ply, speed or inflation practices is not covered by the Titan Tire Warranty Policy.

CT - Contact Titan technical services

Load and Inflation Tables

23.5-25 Articulated Truck Usage Chart Continued

For Standard Earthmover Service: < 2.5 mi, < 30 mph

Manufacturer	Model	Payload	Front	Front	Middle	Middle	Rear	Rear
			Minimum Ply Rating	Minimum Inflation	Minimum Ply Rating	Minimum Inflation	Minimum Ply Rating	Minimum Inflation
		Tons		Psi		Psi		Psi
Deere	250C	25	20	35	16	30	20	35
Deere	250D	25	20	35	20	40	20	40
Deere	250D-II	25	20	35	20	40	20	40
Deere	300C	30	20	40	CT	CT	CT	CT
Deere	300D	30	20	35	CT	CT	CT	CT
Deere	300D-II	30	20	40	CT	CT	CT	CT
Doosan	DA30	31	CT	CT	CT	CT	CT	CT
Komatsu	HA270-1	27	CT	CT	CT	CT	CT	CT
Komatsu	HM300-1	30	CT	CT	CT	CT	CT	CT
Komatsu	HM300-2	30	CT	CT	CT	CT	CT	CT
Komatsu	HM300-3	31	CT	CT	CT	CT	CT	CT
Komatsu	HM300-5	31	CT	CT	CT	CT	CT	CT
Moxy	MT26	26	CT	CT	CT	CT	CT	CT
Moxy	MT30X	30	CT	CT	20	35	20	35
Moxy	MT30LHS	30	CT	CT	CT	CT	CT	CT
Moxy	MT31	31	CT	CT	CT	CT	CT	CT
Randon	RK-628	28	20	35	CT	CT	CT	CT
Terex	2566B	25	CT	CT	20	35	20	35
Terex	2566C	25	CT	CT	20	40	20	35
Terex	2766B	28	CT	CT	20	40	20	40
Terex	2766C	28	CT	CT	CT	CT	20	40
Terex	3066	30	CT	CT	CT	CT	CT	CT
Terex	3066C	30	20	40	CT	CT	CT	CT
Terex	TA250	28	CT	CT	CT	CT	CT	CT
Terex	TA250-9	28	CT	CT	CT	CT	CT	CT
Terex	TA300	31	CT	CT	CT	CT	CT	CT
Terex	TA300-T4	31	CT	CT	CT	CT	CT	CT
Terex	TA300-9	31	CT	CT	CT	CT	CT	CT
Volvo	A20 6X4	20	12	25	-	-	-	-
Volvo	A25	25	16	30	20	40	20	40
Volvo	A25 4X4	25	16	35	-	-	-	-
Volvo	A25 6X4	25	16	30	20	40	20	40
Volvo	A25B	25	16	30	20	40	20	40
Volvo	A25B 4X4	25	16	35	-	-	-	-
Volvo	A25C	25	16	30	20	40	20	40
Volvo	A25C 4X4	25	20	35	-	-	-	-
Volvo	A25C 6X6	25	16	30	20	40	20	40
Volvo	A25D	27	20	40	CT	CT	CT	CT
Volvo	A25E	27	20	40	CT	CT	CT	CT
Volvo	A25E 4X4	27	CT	CT	-	-	-	-
Volvo	A25F	27	20	40	CT	CT	CT	CT
Volvo	A25G	27	CT	CT	CT	CT	CT	CT
Volvo	A30	30	20	40	CT	CT	CT	CT
Volvo	A30C	30	CT	CT	CT	CT	CT	CT
Volvo	A30C 6X6	30	CT	CT	CT	CT	CT	CT
Volvo	A30D	31	CT	CT	CT	CT	CT	CT
Volvo	A30E	31	CT	CT	CT	CT	CT	CT
Volvo	A30F	31	CT	CT	CT	CT	CT	CT
Volvo	A30G	31	CT	CT	CT	CT	CT	CT

Pressure and ply recommendations based on normal quarry operations with standard equipment. For different applications, or modified equipment, please contact OTR Field Engineering for a specific recommendation. Tire damage or failure caused by improper load, ply, speed or inflation practices is not covered by the Titan Tire Warranty Policy.

CT - Contact Titan technical services

26.5-25 Articulated Truck Usage Chart

For Standard Earthmover Service: < 2.5 mi, < 30 mph

Manufacturer	Model	Payload	Front Minimum Ply Rating	Front Minimum Inflation	Middle Minimum Ply Rating	Middle Minimum Inflation	Rear Minimum Ply Rating	Rear Minimum Inflation
		Tons		Psi		Psi		Psi
Bell	B35D	36	26	45	32	55	32	55
Bell	B40	40	32	50	44	60	44	60
Bell	B40B	40	32	50	44	55	44	55
Bell	B40D 6x4	40	26	45	44	60	44	55
Caterpillar	D25C	25	32	50	CT	-	44	55
Caterpillar	D25D	25	32	50	CT	-	44	55
Caterpillar	D350C	35	26	45	26	45	26	45
Caterpillar	D350D	35	32	45	26	45	26	45
Caterpillar	D400D	40	32	50	44	55	44	55
Caterpillar	735	35	32	55	32	55	32	55
Caterpillar	735	36	44	55	32	55	32	50
Caterpillar	735B	36	44	60	32	55	32	50
Caterpillar	735B	36	44	60	32	55	32	50
Caterpillar	735C	36	32	55	32	55	32	50
Deere	350C	35	32	45	32	50	32	50
Deere	350D	35	26	45	32	50	32	50
Deere	350D Series II	35	32	50	32	50	32	50
Deere	370E	37	32	50	44	55	32	55
Komatsu	HM350-2	36	32	50	32	55	32	55
Moxy	MT36	36	32	45	32	50	32	50
Moxy	MT40	40	32	45	32	55	32	55
Terex	4066	37	20	40	32	50	32	50
Terex	4066B	40	26	45	44	55	44	55
Terex	4066C	40	26	45	44	60	44	60
Terex	TA350	38	26	40	44	60	44	60
Volvo	A35	35	20	40	32	50	32	50
Volvo	A35C	35	20	40	32	50	32	50
Volvo	A35C 6X6	35	20	40	32	50	32	50
Volvo	A35D	36	26	40	32	55	32	55
Volvo	A35E	37	26	40	44	55	44	55
Volvo	A35E-FS	37	26	40	44	55	44	55
Volvo	A35F	37	26	45	44	55	44	55
Volvo	A35F-FS	37	26	45	44	55	44	55
Volvo	A35G	37	32	45	44	55	44	55
Volvo	A35G-FS	37	32	45	44	55	44	55

Pressure and ply recommendations based on normal quarry operations with standard equipment. For different applications, or modified equipment, please contact OTR Field Engineering for a specific recommendation. Tire damage or failure caused by improper load, ply, speed or inflation practices is not covered by the Titan Tire Warranty Policy.

CT - Contact Titan technical services

Load and Inflation Tables

29.5-25 Articulated Truck Usage Chart

For Standard Earthmover Service: < 2.5 mi, < 30 mph

Manufacturer	Model	Payload	Front Minimum Ply Rating	Front Minimum Inflation	Middle Minimum Ply Rating	Middle Minimum Inflation	Rear Minimum Ply Rating	Rear Minimum Inflation
		Tons		Psi		Psi		Psi
Atlas	FB-645	45	34	55	34	60	34	60
Bell	B40B	40	28	45	28	50	28	45
Bell	B40D	41	28	40	34	50	34	50
Bell	B45D	45	28	45	38	60	34	60
Caterpillar	D30C 4x4	30	28	45	-	-	38	60
Caterpillar	D30D 4x4	30	28	45	-	-	38	60
Caterpillar	D35C	35	28	45	-	-	CT	-
Caterpillar	D40D	40	34	55	-	-	CT	-
Caterpillar	D350C	35	28	35	28	40	28	35
Caterpillar	D350D	35	28	40	28	40	28	40
Caterpillar	D400D	40	28	45	28	45	28	45
Caterpillar	D400E	40	28	45	28	45	28	45
Caterpillar	740	40	34	50	28	50	28	45
Caterpillar	740	44	34	55	34	55	34	50
Caterpillar	740 EJ	42	28	45	38	60	34	55
Caterpillar	740B	44	34	55	34	55	34	50
Caterpillar	740B EJ	42	28	50	34	60	34	55
Caterpillar	740C EJ	42	28	45	34	60	34	55
Caterpillar	745C	45	34	55	34	55	34	55
Deere	370E	37	28	45	28	45	28	45
Deere	400C	40	28	45	28	45	28	45
Deere	400D	40	28	40	34	50	34	50
Deere	400D Series II	40	28	40	34	55	34	50
Deere	410E	41	28	45	34	50	34	50
Deere	460E	46	28	50	34	55	34	55
Doosan	DA40	44	28	45	34	55	34	55
Doosan	DA40-5	44	28	45	34	55	34	55
Komatsu	HD400	40	28	40	34	50	34	50
Komatsu	HM400-2	40	28	40	34	55	34	55
Komatsu	HM400-3	44	28	45	34	60	34	60
Komatsu	HM400-5	44	28	50	38	60	34	55
Moxy	MT41	41	28	40	34	50	34	50
Moxy	MT51	51	28	45	38	60	38	60
Terex	TA400-9	42	28	40	34	55	34	55
Volvo	A40	40	28	35	34	50	34	50
Volvo	A40D	41	28	40	34	55	34	55
Volvo	A40E	43	28	40	34	55	34	55
Volvo	A40E-FS	43	28	40	34	55	34	55
Volvo	A40F	43	28	45	34	55	34	55
Volvo	A40F-FS	43	28	40	34	55	34	55
Volvo	A40G	43	28	45	34	55	34	55
Volvo	A40G-FS	43	28	45	34	55	34	55
Volvo	A25 4X4	25	-	-	-	-	34	55
Volvo	A25B 4X4	25	-	-	-	-	34	55
Volvo	A25C 4X4	25	-	-	-	-	34	55
Volvo	A25E 4X4	27	-	-	-	-	38	65

Pressure and ply recommendations based on normal quarry operations with standard equipment. For different applications, or modified equipment, please contact OTR Field Engineering for a specific recommendation. Tire damage or failure caused by improper load, ply, speed or inflation practices is not covered by the Titan Tire Warranty Policy.

CT - Contact Titan technical services

13.00-24TG Grader Usage Chart

For Standard Grader Service: Unlimited distance, < 25 mph

Manufacturer	Model	Front Minimum Ply Rating	Front Minimum Inflation	Middle Minimum Ply Rating	Middle Minimum Inflation	Rear Minimum Ply Rating	Rear Minimum Inflation
			Psi		Psi		Psi
Case	845B	12	35	12	45	12	45
Case	865B	12	40	12	45	12	45
Case	865B AWD	12	40	16	45	16	45
Caterpillar	120M2	12	40	CT	CT	CT	CT
Caterpillar	120M2 AWD	12	45	CT	CT	CT	CT

14.00-24TG Grader Usage Chart

For Standard Grader Service: Unlimited distance, < 25 mph

Manufacturer	Model	Front Minimum Ply Rating	Front Minimum Inflation	Middle Minimum Ply Rating	Middle Minimum Inflation	Rear Minimum Ply Rating	Rear Minimum Inflation
			Psi		Psi		Psi
Case	845B	12	25	12	40	12	40
Case	865B	12	25	12	40	12	40
Case	865B AWD	12	30	12	40	12	40
Case	885B	12	35	14	40	14	40
Case	885B AWD	12	40	14	40	14	40
Caterpillar	12M2	12	35	14	45	14	45
Caterpillar	12M2 AWD	12	35	CT	CT	CT	CT
Caterpillar	12M3	12	35	CT	CT	CT	CT
Caterpillar	12M3 AWD	12	35	CT	CT	CT	CT
Caterpillar	120M2	12	30	14	40	14	40
Caterpillar	120M2 AWD	12	30	14	45	14	45
Caterpillar	140H	12	25	12	40	12	40
Caterpillar	140M	12	30	14	45	14	45
Caterpillar	140M AWD	12	35	CT	CT	CT	CT
Caterpillar	140M2	12	35	CT	CT	CT	CT
Caterpillar	140M2 AWD	12	40	CT	CT	CT	CT
Caterpillar	140M3	12	35	CT	CT	CT	CT
Caterpillar	140M3 AWD	14	40	CT	CT	CT	CT
Caterpillar	160M	12	35	CT	CT	CT	CT
Caterpillar	160M AWD	12	40	CT	CT	CT	CT
Caterpillar	160M2	12	35	CT	CT	CT	CT
Caterpillar	160M2 AWD	14	40	CT	CT	CT	CT
Caterpillar	160M3	12	35	CT	CT	CT	CT
Caterpillar	160M3 AWD	14	40	CT	CT	CT	CT
Deere	670G Std	12	25	12	40	12	40
Deere	670G w/ ripper	12	35	14	45	14	45
Deere	672G Std	12	30	12	40	12	40
Deere	672G w/ ripper	12	35	CT	CT	CT	CT
Deere	770G std	12	25	12	40	12	40
Deere	770G w/ ripper	12	35	CT	CT	CT	CT
Deere	772G std	12	30	14	40	14	40
Deere	772G w/ ripper	12	40	CT	CT	CT	CT
Deere	870G std	12	25	14	40	14	40
Deere	870G w/ ripper	12	35	CT	CT	CT	CT

Pressure and ply recommendations based on normal quarry operations with standard equipment. For different applications, or modified equipment, please contact OTR Field Engineering for a specific recommendation. Tire damage or failure caused by improper load, ply, speed or inflation practices is not covered by the Titan Tire Warranty Policy.

CT - Contact Titan technical services

Load and Inflation Tables

14.00-24TG Grader Usage Chart continued

For Standard Grader Service: Unlimited distance, < 25 mph

Manufacturer	Model	Front Minimum Ply Rating	Front Minimum Inflation	Middle Minimum Ply Rating	Middle Minimum Inflation	Rear Minimum Ply Rating	Rear Minimum Inflation
			Psi		Psi		Psi
Deere	872G std	12	30	14	40	14	40
Deere	872G w/ ripper	14	40	CT	CT	CT	CT
Terex	TG140	12	30	12	40	12	40
Terex	TG180	14	40	12	40	12	40
Terex	TG200	14	40	12	40	12	40
Volvo	G930B	12	25	12	40	12	40
Volvo	G930C	12	25	12	40	12	40
Volvo	G940B	12	30	12	40	12	40
Volvo	G940C	12	30	14	40	14	40
Volvo	G946B	12	30	14	40	14	40
Volvo	G946C	12	30	14	40	14	40
Volvo	G960B	12	30	14	40	14	40
Volvo	G960C	12	30	14	40	14	40

16.00-24TG Grader Usage Chart

For Standard Grader Service: Unlimited distance, < 25 mph

Manufacturer	Model	Front Minimum Ply Rating	Front Minimum Inflation	Middle Minimum Ply Rating	Middle Minimum Inflation	Rear Minimum Ply Rating	Rear Minimum Inflation
			Psi		Psi		Psi
Case	845B	16	20	16	40	16	40
Case	865B	16	20	16	40	16	40
Case	865B AWD	16	25	16	40	16	40
Case	885B	16	25	16	40	16	40
Case	885B AWD	16	30	16	40	16	40
Caterpillar	14M	16	30	CT	CT	CT	CT

17.5-25 Grader Usage Chart

For Standard Grader Service: Unlimited distance, < 25 mph

Manufacturer	Model	Front Minimum Ply Rating	Front Minimum Inflation	Middle Minimum Ply Rating	Middle Minimum Inflation	Rear Minimum Ply Rating	Rear Minimum Inflation
			Psi		Psi		Psi
Case	845B	12	20	12	40	12	40
Case	865B	12	25	12	40	12	40
Case	865B AWD	12	25	12	40	12	40
Case	885B	12	30	16	40	16	40
Case	885B AWD	16	CT	16	40	16	40
Caterpillar	12M2	12	30	20	40	20	40
Caterpillar	12M2 AWD	16	CT	20	40	20	40
Caterpillar	12M3	12	30	20	40	20	40
Caterpillar	12M3 AWD	16	CT	20	40	20	40
Caterpillar	120M2	12	25	16	40	16	40
Caterpillar	120M2 AWD	12	30	20	40	20	40

Pressure and ply recommendations based on normal quarry operations with standard equipment. For different applications, or modified equipment, please contact OTR Field Engineering for a specific recommendation. Tire damage or failure caused by improper load, ply, speed or inflation practices is not covered by the Titan Tire Warranty Policy.

CT - Contact Titan technical services

17.5-25 Grader Usage Chart continued

For Standard Grader Service: Unlimited distance, < 25 mph

Manufacturer	Model	Front Minimum Ply Rating	Front Minimum Inflation	Middle Minimum Ply Rating	Middle Minimum Inflation	Rear Minimum Ply Rating	Rear Minimum Inflation
			Psi		Psi		Psi
Caterpillar	140H	12	20	12	40	12	40
Caterpillar	140M	12	30	20	40	20	40
Caterpillar	140M AWD	12	30	20	40	20	40
Caterpillar	140M2	12	30	20	40	20	40
Caterpillar	140M2 AWD	16	CT	20	40	20	40
Caterpillar	140M3	12	30	20	40	20	40
Caterpillar	140M3 AWD	16	CT	CT	40	CT	40
Caterpillar	160M	12	30	20	40	20	40
Caterpillar	160M AWD	16	CT	20	40	20	40
Caterpillar	160M2	16	CT	20	40	20	40
Caterpillar	160M2 AWD	16	CT	CT	CT	CT	CT
Caterpillar	160M3	16	CT	CT	40	CT	40
Caterpillar	160M3 AWD	16	CT	CT	CT	CT	CT
Deere	670G Std	12	20	16	40	16	40
Deere	670G w/ ripper	12	30	20	40	20	40
Deere	672G Std	12	25	16	40	16	40
Deere	672G w/ ripper	16	CT	20	40	20	40
Deere	770G std	12	20	16	40	16	40
Deere	770G w/ ripper	12	30	20	40	20	40
Deere	772G std	12	25	16	40	16	40
Deere	772G w/ ripper	16	CT	20	40	20	40
Deere	870G std	12	25	16	40	16	40
Deere	870G w/ ripper	12	30	20	40	20	40
Deere	872G std	12	25	16	40	16	40
Deere	872G w/ ripper	16	CT	CT	CT	CT	CT
Komatsu	GD655-5	12	25	12	40	12	40
Komatsu	GD655-5 w/ ripper	12	30	16	40	16	40
Komatsu	GD655-5 w/ scarifier	12	25	16	40	16	40
Volvo	G930B	12	25	12	40	12	40
Volvo	G930C	12	25	20	40	20	40
Volvo	G940B	12	25	16	40	16	40
Volvo	G940C	12	25	CT	CT	CT	CT
Volvo	G946B	12	25	16	40	16	40
Volvo	G946C	12	30	CT	CT	CT	CT
Volvo	G960B	12	25	16	40	16	40
Volvo	G960C	12	30	CT	CT	CT	CT

Pressure and ply recommendations based on normal quarry operations with standard equipment. For different applications, or modified equipment, please contact OTR Field Engineering for a specific recommendation. Tire damage or failure caused by improper load, ply, speed or inflation practices is not covered by the Titan Tire Warranty Policy.

CT - Contact Titan technical services

Load and Inflation Tables

15.5-25 Loader Usage Chart

For Standard Loader Service: <250 ft, < 5 mph

Manufacturer	Model	Bucket	Front	Front	Rear	Rear
			Minimum Ply Rating	Minimum Inflation	Minimum Ply Rating	Minimum Inflation
		Cu.Yd.		Psi		Psi
Caterpillar	910K	1.7	12	55	12	35
Caterpillar	914G2	1.8	24	55	24	35
Hitachi	ZW100	1.7	24	55	24	35
Hitachi	ZW100 HL	1.4	24	50	24	35
Komatsu	WA150-5	1.6	24	50	24	35
Volvo	L45H	2	24	65	24	40
Volvo	L50H	2.1	24	70	24	40

17.5-25 Loader Usage Chart

For Standard Loader Service: <250 ft, < 5 mph

Manufacturer	Model	Bucket	Front	Front	Rear	Rear
			Minimum Ply Rating	Minimum Inflation	Minimum Ply Rating	Minimum Inflation
		Cu.Yd.		Psi		Psi
Caterpillar	IT14B	1.6	12	50	12	35
Caterpillar	IT14F	1.6	12	50	12	35
Caterpillar	IT14G	1.7	12	45	12	35
Caterpillar	IT18	1.5	12	50	12	35
Caterpillar	IT18B	1.75	12	55	12	35
Caterpillar	IT18F	2	12	60	12	35
Caterpillar	IT24	2.3	12	60	12	35
Caterpillar	IT24F	2.4	12	65	12	35
Caterpillar	IT28	2	12	55	12	35
Caterpillar	IT28B	2.25	12	60	12	35
Caterpillar	IT28F	2.6	12	65	12	40
Caterpillar	914G	1.7	12	45	12	35
Caterpillar	914G2	1.8	12	50	12	35
Caterpillar	914K	1.7	12	45	12	35
Caterpillar	914K HL	1.7	12	50	12	35
Caterpillar	916	2	12	50	12	35
Caterpillar	918F	2	12	55	12	35
Caterpillar	924F	2.25	12	55	12	35
Caterpillar	924Gz	2.3	12	60	12	35
Caterpillar	924K	2.5	16	75	12	45
Caterpillar	926	1.75	12	50	12	35
Caterpillar	926E	2.25	12	55	12	35
Caterpillar	926M	2.5	16	75	12	45
Caterpillar	928F	2.6	12	65	12	35
Caterpillar	928G	2.6	12	65	12	40
Caterpillar	930	2.25	12	60	12	35
Caterpillar	936	2.75	16	75	12	45
Caterpillar	936E	3	16	80	12	45
Caterpillar	936F	3	16	80	12	45

For service under chains, or load and carry operations, contact Titan Technical Services.

Pressure and ply recommendations based on normal quarry operations with standard equipment. For different applications, or modified equipment, please contact OTR Field Engineering for a specific recommendation. Tire damage or failure caused by improper load, ply, speed or inflation practices is not covered by the Titan Tire Warranty Policy.

CT - Contact Titan Technical services

HL - High Lift, extended booms, etc.

17.5-25 Loader Usage Chart continued

For Standard Loader Service: <250 ft, < 5 mph

Manufacturer	Model	Bucket	Front	Front	Rear	Rear
			Minimum Ply Rating	Minimum Inflation	Minimum Ply Rating	Minimum Inflation
		Cu.Yd.		Psi		Psi
Case	W14C	1.7	12	45	12	35
Case	W18	2	12	55	12	35
Case	W18B	2	12	55	12	35
Case	W20	2	12	60	12	35
Case	W20B	2.5	12	60	12	35
Case	W20C	2	12	55	12	35
Case	W24B	2.5	12	60	12	35
Case	W24C	3	16	70	12	40
Case	521D	2	12	55	12	35
Case	621	2.2	12	65	12	35
Daewoo	Mega 200	2.4	12	60	12	35
Daewoo	Mega 200-III	2.3	12	60	12	35
Deere	304H	1.25	12	50	12	35
Deere	304H WH	1	12	45	12	35
Deere	324H	1.75	12	55	12	35
Deere	344E	1.6	12	45	12	35
Deere	344G	1.6	12	45	12	35
Deere	344H	2	12	45	12	35
Deere	344K	1.75	12	50	12	35
Deere	444	1.5	12	45	12	35
Deere	444C	1.75	12	50	12	35
Deere	444D	1.75	12	50	12	35
Deere	444E	1.75	12	50	12	35
Deere	444G	1.75	12	50	12	35
Deere	444H	2.5	12	60	12	35
Deere	444H-HL	2.5	12	65	12	40
Deere	444K Z-bar	2.5	12	65	12	40
Deere	444K HL	2.5	16	70	12	40
Deere	444K Powerllel	2.5	16	75	12	45
Deere	544B	1.75	12	55	12	35
Deere	544C	2	12	55	12	35
Deere	544D	2.2	12	60	12	35
Deere	544E	2.2	12	60	12	35
Deere	544G	2.5	12	65	12	35
Deere	544G-TC	2.5	12	65	12	40
Deere	TC44H	2	12	55	12	35
Deere	TC54H	2.5	12	60	12	35
Deere	TC62H	3	12	60	12	35
Fiattalis	FR7B	1.4	12	40	12	35
Fiattalis	FR7C	1.4	12	40	12	35
Fiattalis	FR70	1.4	12	40	12	35
Fiattalis	345B	1.5	12	45	12	35
Fiattalis	FR9B PL	1.7	12	50	12	35

For service under chains, or load and carry operations, contact Titan Technical Services.

Pressure and ply recommendations based on normal quarry operations with standard equipment. For different applications, or modified equipment, please contact OTR Field Engineering for a specific recommendation. Tire damage or failure caused by improper load, ply, speed or inflation practices is not covered by the Titan Tire Warranty Policy.

CT - Contact Titan Technical services

HL - High Lift, extended booms, etc.

Load and Inflation Tables

17.5-25 Loader Usage Chart continued

For Standard Loader Service: <250 ft, < 5 mph

Manufacturer	Model	Bucket	Front	Front	Rear	Rear
			Minimum Ply Rating	Minimum Inflation	Minimum Ply Rating	Minimum Inflation
		Cu.Yd.		Psi		Psi
Fiattalis	FR90 PL	1.8	12	55	12	35
Fiattalis	FR9B	1.8	12	50	12	35
Fiattalis	FR9C	1.8	12	45	12	35
Fiattalis	FR90	1.8	12	50	12	35
Fiattalis	FR10	2	12	55	12	35
Fiattalis	FR10B	2.2	12	55	12	35
Fiattalis	FR10C	2.25	12	55	12	35
Fiattalis	FR100	2.25	12	55	12	35
Fiattalis	FR11	2.5	12	65	12	40
Fiattalis	FR12	2.5	12	65	12	40
Fiattalis	FR12B	2.5	12	60	12	35
Fiattalis	FR120	2.5	12	60	12	35
Fiattalis	FR120-2	2.5	12	65	12	40
Fiattalis	FW130	2.75	16	70	12	45
Fiattalis	FW110	2.2	12	55	12	35
Fiat Hitachi	W110	2.1	12	55	12	35
Fiat Hitachi	W130 PL	2.6	12	65	12	40
Furukawa	FL120-I	1.7	12	50	12	35
Furukawa	FL120A-I	1.7	12	50	12	35
Hitachi	ZW120	2	12	50	12	35
Hitachi	ZW120 HL	1.75	12	50	12	35
Hitachi	ZW140	2.6	12	65	12	35
Hitachi	ZW140 HL	2	12	60	12	35
Hyundai	HL17	2.4	12	65	12	40
Hyundai	HL730-9A	2.5	12	60	12	35
Hyundai	HL730XTD-9A	2.5	12	65	12	35
Hyundai	HL730TM-9A	2.2	12	60	12	35
Hyundai	HL740-9A	3	16	80	12	45
Hyundai	HL740XTD-9A	3	20	80	12	50
Hyundai	HL740TM-9A	3	20	85	12	55
Hyundai	HL757-9A	3.7	20	90	16	55
Hyundai	HL757XTD-9A	3.7	24	100	16	65
Hyundai	HL757TM-9A	3.5	24	95	16	60
Hyundai	HL940	3	16	75	12	45
Hyundai	HL940 XT	3	16	80	12	50
Hyundai	HL955	3.1	20	85	12	50
Hyundai	HL955 XTD	3.1	20	90	16	55
JCB	416HT	2.2	12	55	12	35
Kawasaki	50ZIV	1.7	12	45	12	35
Kawasaki	50ZIV-2	2	12	45	12	35
Kawasaki	60Z	2.1	12	55	12	35
Kawasaki	60ZII	2.1	12	55	12	35
Kawasaki	60ZIII	2.1	12	50	12	35

For service under chains, or load and carry operations, contact Titan Technical Services.

Pressure and ply recommendations based on normal quarry operations with standard equipment. For different applications, or modified equipment, please contact OTR Field Engineering for a specific recommendation. Tire damage or failure caused by improper load, ply, speed or inflation practices is not covered by the Titan Tire Warranty Policy.

CT - Contact Titan Technical services

HL - High Lift, extended booms, etc.

17.5-25 Loader Usage Chart continued

For Standard Loader Service: <250 ft, < 5 mph

Manufacturer	Model	Bucket Cu.Yd.	Front	Front	Rear	Rear
			Minimum Ply Rating	Minimum Inflation Psi	Minimum Ply Rating	Minimum Inflation Psi
Kawasaki	60ZIV	2.1	12	50	12	35
Kawasaki	60ZIV-2	2.5	12	55	12	35
Kawasaki	60Z7	2	12	50	12	35
Kawasaki	60ZV-2	2.2	12	55	12	35
Kawasaki	60ZV-2 HL	2.2	12	60	12	35
Kawasaki	60ZV-2 SHL	2.2	12	60	12	35
Kawasaki	62Z7	2.75	12	65	12	40
Kawasaki	65TM-2	2.6	16	80	12	50
Kawasaki	65Z	2.3	12	60	12	35
Kawasaki	65ZII	2.3	12	60	12	35
Kawasaki	65ZIII	2.6	12	65	12	35
Kawasaki	65ZIV	2.6	12	65	12	35
Kawasaki	65ZIV-2	3	16	70	12	45
Kawasaki	65ZV-2	3	16	70	12	40
Kawasaki	65ZV-2 HL	2.8	16	70	12	40
Kawasaki	65ZV-2 SHL	2.8	16	70	12	45
Komatsu	WA120-1	1.75	12	50	12	35
Komatsu	WA120-3	1.85	12	45	12	35
Komatsu	WA150-5	2	12	50	12	35
Komatsu	WA180-1	2.25	12	55	12	35
Komatsu	WA180-3	2.9	12	65	12	35
Komatsu	WA180-3 PTC	2.5	12	65	12	35
Komatsu	WA200-5	2.6	12	60	12	35
Komatsu	WA200-6	2.6	12	60	12	35
Komatsu	WA200PZ-6	2.6	12	65	12	40
Komatsu	WA200-7	2.6	12	65	12	40
Komatsu	WA250-5	3	16	70	12	40
Komatsu	WA250-6	3	12	65	12	40
Komatsu	WA250PZ-6	2.9	16	75	12	45
Komatsu Dresser	512	1.7	12	50	12	35
Komatsu Dresser	515B	1.6	12	45	12	35
Komatsu Dresser	515C	2	12	50	12	35
Komatsu Dresser	515CH	2	12	55	12	35
Komatsu Dresser	518	2.2	12	55	12	35
Komatsu Dresser	520B	2.25	12	60	12	35
Komatsu Dresser	520C	2.5	12	60	12	35
Liebherr	L524 Z-bar	2.7	12	65	12	40
Liebherr	L524	2.4	12	65	12	40
Liebherr	L524 HL	2.4	16	70	12	45
Liebherr	L528 Z-bar	3	16	70	12	40
Liebherr	L528	2.7	16	70	12	40
Liebherr	L528 HL	2.7	16	80	12	45
Terex	33C	1.75	12	50	12	35

For service under chains, or load and carry operations, contact Titan Technical Services.

Pressure and ply recommendations based on normal quarry operations with standard equipment. For different applications, or modified equipment, please contact OTR Field Engineering for a specific recommendation. Tire damage or failure caused by improper load, ply, speed or inflation practices is not covered by the Titan Tire Warranty Policy.

CT - Contact Titan Technical services

HL - High Lift, extended booms, etc.

Load and Inflation Tables

17.5-25 Loader Usage Chart continued

For Standard Loader Service: <250 ft, < 5 mph

Manufacturer	Model	Bucket	Front Minimum Ply Rating	Front Minimum Inflation	Rear Minimum Ply Rating	Rear Minimum Inflation
		Cu.Yd.		Psi		Psi
Terex	44C	2.25	12	65	12	40
Volvo	L45H	2	12	55	12	35
Volvo	L50C	2	12	50	12	35
Volvo	L50D	2	12	55	12	35
Volvo	L50H	2.1	12	55	12	35
Volvo	L60G	2.75	16	70	12	40
Volvo	L60H	2.75	16	70	12	40
Volvo	L70B	2.1	12	60	12	35
Volvo	L70C	2.5	12	60	12	35
Volvo	L70D	2.5	12	65	12	40

20.5-25 Loader Usage Chart continued

For Standard Loader Service: <250 ft, < 5 mph

Manufacturer	Model	Bucket	Front Minimum Ply Rating	Front Minimum Inflation	Rear Minimum Ply Rating	Rear Minimum Inflation
		Cu.Yd.		Psi		Psi
Caterpillar	IT38F	3.25	16	60	12	35
Caterpillar	IT38G	3.3	16	60	12	35
Caterpillar	IT38H	3.3	16	65	12	35
Caterpillar	924G	2.3	12	45	12	35
Caterpillar	924H	2.4	12	45	12	35
Caterpillar	924HZ	2.3	12	45	12	35
Caterpillar	924K	2.5	12	55	12	35
Caterpillar	926M	2.5	16	55	12	35
Caterpillar	928HZ	2.6	12	50	12	35
Caterpillar	930H	2.7	12	55	12	35
Caterpillar	930K	2.75	16	55	12	35
Caterpillar	930M	2.75	16	55	12	35
Caterpillar	936F TC	3	16	55	12	35
Caterpillar	938F	3.25	16	55	12	35
Caterpillar	938G	3.25	16	60	12	35
Caterpillar	938H	3.65	20	65	16	40
Caterpillar	938K	3.25	16	65	12	35
Caterpillar	938M	3.25	20	65	16	40
Caterpillar	950B	3.75	20	70	16	40
Caterpillar	950F	4	20	75	16	45
Case	621B	2.25	12	45	12	35
Case	621B	3	12	55	12	35
Case	621B XT	2.25	12	50	12	35
Case	621D	2.5	12	50	12	35
Case	621E	3	12	55	12	35
Case	621E XT	3	16	55	12	35

For service under chains, or load and carry operations, contact Titan Technical Services.

Pressure and ply recommendations based on normal quarry operations with standard equipment. For different applications, or modified equipment, please contact OTR Field Engineering for a specific recommendation. Tire damage or failure caused by improper load, ply, speed or inflation practices is not covered by the Titan Tire Warranty Policy.

CT - Contact Titan Technical services

HL - High Lift, extended booms, etc.

20.5-25 Loader Usage Chart continued

For Standard Loader Service: <250 ft, < 5 mph

Manufacturer	Model	Bucket	Front	Front	Rear	Rear
			Minimum Ply Rating	Minimum Inflation	Minimum Ply Rating	Minimum Inflation
		Cu.Yd.		Psi		Psi
Case	621E XR	3	16	55	12	35
Case	721	2.75	12	50	12	35
Case	721B	2.75	12	50	12	35
Case	721B XT	2.75	16	55	12	35
Case	721C	2.75	16	55	12	35
Case	721E	3.5	16	60	12	35
Case	721E XT	3	16	55	12	35
Case	721E XR	3	16	55	12	35
Case	721F	3	16	55	12	35
Case	721F XT	3	16	60	12	35
Case	721F XR	3	16	60	12	35
Case	W30	3.5	16	55	12	35
Daewoo	Mega 250-III	3.1	16	55	12	35
Deere	444K Z-bar	2.5	12	50	12	35
Deere	444K HL	2.5	12	50	12	35
Deere	444K PowerIlel	2.5	12	50	12	35
Deere	524K Z-bar	2.75	12	50	12	35
Deere	524K HL	2.75	12	55	12	35
Deere	544H	3	12	55	12	35
Deere	544H-HL	3	16	55	12	35
Deere	544K	3	16	55	12	35
Deere	544K-HL	3	16	55	12	35
Deere	624E	2.6	12	50	12	35
Deere	624G	3.25	16	55	12	35
Deere	624H	3.5	16	60	12	35
Deere	624H-HL	3	16	60	12	35
Deere	624K	3.5	16	60	12	35
Deere	624K-HL	3.5	16	65	12	35
Deere	644B	2.5	12	50	12	35
Deere	644C	3	12	55	12	35
Doosan	DL200	2.6	12	50	12	35
Doosan	DL200TC	2.6	12	50	12	35
Doosan	DL250	3.3	16	60	12	35
Doosan	DL250TC	3.4	16	65	12	35
Doosan	DL250HL	3.4	16	60	12	35
Dressta	520E	2.3	12	45	12	35
Fiattallis	FR130	3	16	55	12	35
Fiattallis	FR130-2	3	16	55	12	35
Fiattallis	FR140	3	16	55	12	35
Fiattallis	FR140-2	3.25	16	55	12	35
Fiattallis	FR15	3	16	55	12	35
Fiattallis	FR15B	3.1	16	60	12	35
Fiat Hitachi	W170 PL	3.9	20	65	12	40

For service under chains, or load and carry operations, contact Titan Technical Services.

Pressure and ply recommendations based on normal quarry operations with standard equipment. For different applications, or modified equipment, please contact OTR Field Engineering for a specific recommendation. Tire damage or failure caused by improper load, ply, speed or inflation practices is not covered by the Titan Tire Warranty Policy.

CT - Contact Titan Technical services

HL - High Lift, extended booms, etc.

Load and Inflation Tables

20.5-25 Loader Usage Chart continued

For Standard Loader Service: <250 ft, < 5 mph

Manufacturer	Model	Bucket	Front	Front	Rear	Rear
			Minimum Ply Rating	Minimum Inflation	Minimum Ply Rating	Minimum Inflation
		Cu.Yd.		Psi		Psi
Furukawa	FL150-I	2	12	40	12	35
Furukawa	FL200-I	2.6	12	50	12	35
Furukawa	FL230-I	3.1	16	60	12	35
Hitachi	ZW150	3	12	55	12	35
Hitachi	ZW150 HL	2.6	12	50	12	35
Hitachi	ZW180	3.6	16	60	12	35
Hitachi	ZW180 HL	3.1	16	60	12	35
Hyundai	HL25	3.5	20	70	16	40
Hyundai	HL740-7A	2.7	12	50	12	35
Hyundai	HL740XTD-7A	2.7	12	50	12	35
Hyundai	HL740TM-7A	2.6	12	50	12	35
Hyundai	HL740-9A	3	16	55	12	35
Hyundai	HL740XTD-9A	3	16	60	12	35
Hyundai	HL740TM-9A	3	16	60	12	35
Hyundai	HL750	3	16	55	12	35
Hyundai	HL757-7A	2.7	16	55	12	35
Hyundai	HL757XTD-7A	2.7	16	55	12	35
Hyundai	HL757TM-7A	2.5	16	55	12	35
Hyundai	HL757-9A	3.7	16	65	12	35
Hyundai	HL757XTD-9A	3.7	20	70	16	40
Hyundai	HL757TM-9A	3.5	20	70	16	40
Hyundai	HL760-9A	4.3	24	75	16	45
Hyundai	HL760XTD-9A	4.3	24	80	16	50
Hyundai	HL940	3	16	55	12	35
Hyundai	HL940 XT	3	16	55	12	35
Hyundai	HL955	3.1	16	60	12	35
Hyundai	HL955 XTD	3.1	16	60	12	35
Hyundai	HL960	3.8	20	75	16	45
Hyundai	HL960 XT	3.8	20	75	16	45
JCB	426HT	2.5	12	50	12	35
JCB	426HT	2.75	16	55	12	35
JCB	426ZX	2.5	12	50	12	35
JCB	426ZX	2.75	12	50	12	35
JCB	436HT	3.5	16	60	12	35
JCB	436ZX	3.5	16	65	12	35
JCB	456HT	4.6	CT	CT	20	55
Kawasaki	62Z7	2.75	12	50	12	35
Kawasaki	62Z7 HL	2.75	12	50	12	35
Kawasaki	65ZV-2	3	12	50	12	35
Kawasaki	65TMV-2	2.5	12	50	12	35
Kawasaki	67Z7	3.1	12	55	12	35
Kawasaki	67Z7 HL	3.1	16	55	12	35
Kawasaki	70Z	3	16	55	12	35
Kawasaki	70ZII	3	16	55	12	35

For service under chains, or load and carry operations, contact Titan Technical Services.

Pressure and ply recommendations based on normal quarry operations with standard equipment. For different applications, or modified equipment, please contact OTR Field Engineering for a specific recommendation. Tire damage or failure caused by improper load, ply, speed or inflation practices is not covered by the Titan Tire Warranty Policy.

CT - Contact Titan Technical services

HL - High Lift, extended booms, etc.

20.5-25 Loader Usage Chart continued

For Standard Loader Service: <250 ft, < 5 mph

Manufacturer	Model	Bucket	Front	Front	Rear	Rear
			Minimum Ply Rating	Minimum Inflation	Minimum Ply Rating	Minimum Inflation
		Cu.Yd.		Psi		Psi
Kawasaki	70ZIII	3.25	16	55	12	35
Kawasaki	70ZIV	3.25	16	55	12	35
Kawasaki	70ZIV-2	3.5	16	60	12	35
Kawasaki	70ZV-2	3.5	16	55	12	35
Kawasaki	70TMV-2	3.4	20	65	12	40
Kawasaki	70Z7	3.7	16	65	12	35
Kawasaki	70Z7 HL	3.7	20	70	16	40
Kawasaki	80ZV-2	4.2	20	75	16	45
Komatsu	WA200-5	2.6	12	45	12	35
Komatsu	WA200-6	2.6	12	45	12	35
Komatsu	WA200PZ-6	2.5	12	50	12	35
Komatsu	WA200-7	2.6	12	50	12	35
Komatsu	WA250-1	3	12	50	12	35
Komatsu	WA250-3	3.5	16	55	12	35
Komatsu	WA250-3 PTC	3	16	55	12	35
Komatsu	WA250-5	3	12	50	12	35
Komatsu	WA250-6	3	12	50	12	35
Komatsu	WA250PZ-6	3	16	55	12	35
Komatsu	WA270-7	3	16	55	12	35
Komatsu	WA320-1	3.25	16	55	12	35
Komatsu	WA320-3	4.2	20	65	12	40
Komatsu	WA320-6	3.7	16	60	12	35
Komatsu	WA320PZ-6	3.5	20	65	12	40
Komatsu	WA320-7	3.7	20	65	12	40
Komatsu Dresser	520CH	2.5	12	45	12	35
Komatsu Dresser	525	2.7	12	50	12	35
Komatsu Dresser	530	3	16	55	12	35
Komatsu Dresser	530C	3	16	55	12	35
Komatsu Dresser	532	3.2	16	60	12	35
Liebherr	L538 Z-bar	3.4	16	55	12	35
Liebherr	L538	3	16	55	12	35
Liebherr	L538 HL	3	16	60	12	35
Liebherr	L542 Z-bar	3.7	16	65	12	35
Liebherr	L542	3.3	16	60	12	35
Liebherr	L542 HL	3.3	16	65	12	35
New Holland	W170B	3	16	55	12	35
New Holland	W170B TC/LR	3	16	55	12	35
Terex	55C	3	16	55	12	35
Terex	TL210	4.6	20	70	16	45
Terex	TL260	5.9	CT	CT	20	55
Volvo	L60F	2.7	12	50	12	35
Volvo	L60G	2.75	12	50	12	35
Volvo	L60H	2.75	12	50	12	35

For service under chains, or load and carry operations, contact Titan Technical Services.

Pressure and ply recommendations based on normal quarry operations with standard equipment. For different applications, or modified equipment, please contact OTR Field Engineering for a specific recommendation. Tire damage or failure caused by improper load, ply, speed or inflation practices is not covered by the Titan Tire Warranty Policy.

CT - Contact Titan Technical services

HL - High Lift, extended booms, etc.

Load and Inflation Tables

20.5-25 Loader Usage Chart continued

For Standard Loader Service: <250 ft, < 5 mph

Manufacturer	Model	Bucket	Front Minimum Ply Rating	Front Minimum Inflation	Rear Minimum Ply Rating	Rear Minimum Inflation
		Cu.Yd.		Psi		Psi
Volvo	L70B	2.1	12	45	12	35
Volvo	L70C	2.5	12	45	12	35
Volvo	L70D	2.5	12	45	12	35
Volvo	L70F	3	16	55	12	35
Volvo	L70G	3	16	55	12	35
Volvo	L70H	3	16	55	12	35
Volvo	L90B	3	16	55	12	35
Volvo	L90C	3.5	16	65	12	35
Volvo	L90D	3.5	20	65	12	40
Volvo	L90E	3.25	16	60	12	35
Volvo	L90F	3.5	20	65	12	40
Volvo	L90G	3.25	16	60	12	35
Volvo	L90H	3.25	16	60	12	35

23.5-25 Loader Usage Chart

For Standard Loader Service: <250 ft, < 5 mph

Manufacturer	Model	Bucket	Front Minimum Ply Rating	Front Minimum Inflation	Rear Minimum Ply Rating	Rear Minimum Inflation
		Cu.Yd.		Psi		Psi
Caterpillar	950F TC	4	16	60	12	35
Caterpillar	950E	4	16	60	12	35
Caterpillar	950F-II	4	20	60	12	35
Caterpillar	950G	3.9	16	60	12	35
Caterpillar	950G -II	2.7	12	50	12	35
Caterpillar	950H	4	20	60	12	35
Caterpillar	950K	3.5	16	55	12	35
Caterpillar	950L	7.472	16	60	12	35
Caterpillar	950M	4.5	20	65	16	40
Caterpillar	960F	4.5	20	65	16	40
Caterpillar	962G	4.25	20	65	16	35
Caterpillar	962H	4.5	20	65	16	40
Caterpillar	962K	3.5	16	60	12	35
Caterpillar	962L	3.878	20	60	12	35
Caterpillar	962M	4.7	24	70	16	40
Caterpillar	966C	4	20	60	12	35
Caterpillar	966D	4.25	20	65	16	40
Caterpillar	IT62H	4.25	20	65	16	35
Case	821	3.5	12	50	12	35
Case	821B	3.5	16	50	12	35
Case	821C	3.5	16	55	12	35
Case	821E	4.5	20	60	12	35

For service under chains, or load and carry operations, contact Titan Technical Services.

Pressure and ply recommendations based on normal quarry operations with standard equipment. For different applications, or modified equipment, please contact OTR Field Engineering for a specific recommendation. Tire damage or failure caused by improper load, ply, speed or inflation practices is not covered by the Titan Tire Warranty Policy.

CT - Contact Titan Technical services

HL - High Lift, extended booms, etc.

23.5-25 Loader Usage Chart continued

For Standard Loader Service: <250 ft, < 5 mph

Manufacturer	Model	Bucket Cu.Yd.	Front Minimum Ply Rating	Front Minimum Inflation	Rear Minimum Ply Rating	Rear Minimum Inflation
				Psi		Psi
Case	821E XR	4.5	20	65	16	35
Case	821F	3.5	16	55	12	35
Case	821F XR	3.5	16	55	12	35
Case	921F	4.75	20	65	16	35
Case	921F XR	4.75	24	70	16	40
Case	W36	4	16	55	12	35
Daewoo	Mega 300	3.8	16	55	12	35
Daewoo	Mega 300-III	2.9	12	50	12	35
Deere	644D	3.2	12	50	12	35
Deere	644E	3.2	12	50	12	35
Deere	644G	4	16	55	12	35
Deere	644H	4.25	16	55	12	35
Deere	644H-HL	4.25	20	60	12	35
Deere	644H-MH	4.5	20	60	12	35
Deere	644H-WH	6	24	75	16	45
Deere	644K	4.25	20	60	12	35
Deere	644K-HL	4.25	20	65	16	35
Deere	644K-WH	5	24	70	16	45
Deere	724J	4.75	20	65	16	35
Deere	724J-HL	4.25	20	60	16	35
Deere	724K	4.75	20	65	16	35
Deere	724K-HL	4.25	20	65	16	35
Doosan	DL300	4.2	16	60	12	35
Doosan	DL300-5	4.2	20	60	12	35
Doosan	DL300-5 HL	4.2	20	65	16	40
Doosan	DL350-5	4.8	20	65	16	40
Doosan	DL350-5 HL	4.8	24	70	16	45
Fiattalis	FR160	3.6	16	50	12	35
Fiattalis	FR160-2	4	16	55	12	35
Fiattalis	FR180	4	16	55	12	35
Fiattalis	FR180-2	4	16	55	12	35
Fiattalis	FR20	4.5	20	65	16	35
Fiattalis	FR20B	4.6	20	65	16	40
Fiat Hitachi	W190	3.3	12	50	12	35
Fiat Hitachi	W230	4.6	20	65	16	35
Fiat Hitachi	FR160-2	4	16	55	12	35
Hitachi	ZW220	4.2	16	60	12	35
Hitachi	ZW220 HL	3.5	16	55	12	35
Hitachi	ZW250	4.5	20	65	16	35
Hitachi	ZW250 HL	4	20	65	16	35
Hyundai	HL35	4.8	24	70	16	40
Hyundai	HL760	4	20	60	12	35
Hyundai	HL760-7A	4	16	60	12	35

For service under chains, or load and carry operations, contact Titan Technical Services.

Pressure and ply recommendations based on normal quarry operations with standard equipment. For different applications, or modified equipment, please contact OTR Field Engineering for a specific recommendation. Tire damage or failure caused by improper load, ply, speed or inflation practices is not covered by the Titan Tire Warranty Policy.

CT - Contact Titan Technical services

HL - High Lift, extended booms, etc.

Load and Inflation Tables

23.5-25 Loader Usage Chart continued

For Standard Loader Service: <250 ft, < 5 mph

Manufacturer	Model	Bucket	Front Minimum Ply Rating	Front Minimum Inflation	Rear Minimum Ply Rating	Rear Minimum Inflation
		Cu.Yd.		Psi		Psi
Hyundai	HL760-XTD-7A	4	20	60	12	35
Hyundai	HL760-9	4.3	20	60	12	35
Hyundai	HL760XTD-9	4.3	20	65	16	35
Hyundai	HL760-9A	4.3	20	60	12	35
Hyundai	HL760XTD-9A	4.3	20	65	16	35
Hyundai	HL770-7	5.2	24	75	20	45
Hyundai	HL770-XTD-7	5.2	CT	CT	20	45
Hyundai	HL770-7A	4	20	65	16	35
Hyundai	HL770-XTD-7A	4	24	70	16	40
Hyundai	HL770-9	5.5	24	75	20	45
Hyundai	HL770XTD-9	5.5	CT	CT	20	50
Hyundai	HL770-9A	5.5	24	80	20	45
Hyundai	HL770XTD-9A	5.5	CT	CT	20	50
Hyundai	HL960	3.8	16	60	12	35
Hyundai	HL960 XT	3.8	16	60	12	35
Hyundai	HL970	4.7	24	70	16	40
Hyundai	HL970 XTD	4.7	24	75	20	45
JCB	456ZX	4.3	20	60	16	35
Kawasaki	70ZV-2	3.5	16	50	12	35
Kawasaki	70ZV-2 HL	3.5	16	55	12	35
Kawasaki	70TMV-2	3.4	16	55	12	35
Kawasaki	70Z7	3.7	16	50	12	35
Kawasaki	70Z7 HL	3.7	16	55	12	35
Kawasaki	80Z	3.75	16	55	12	35
Kawasaki	80ZII	3.75	16	55	12	35
Kawasaki	80ZIII	3.75	16	55	12	35
Kawasaki	80ZIV	3.75	16	55	12	35
Kawasaki	80ZIV-2	4	16	55	12	35
Kawasaki	80ZV-2	4.2	20	60	12	35
Kawasaki	80Z7	4.2	16	60	12	35
Kawasaki	80Z7 HL	4.2	20	60	12	35
Kawasaki	85Z7	4.8	20	65	16	40
Kawasaki	85Z7 HL	4.8	24	70	16	45
Kawasaki	90Z7	5.5	CT	CT	20	50
Kawasaki	90Z7 HL	5.5	CT	CT	20	50
Kawasaki	90Z7B	5.5	CT	CT	20	45
Kawasaki	90Z7B HL	5.5	CT	CT	20	50
Komatsu	WA380-3	5.25	20	65	16	40
Komatsu	WA380-6	4.3	16	60	12	35
Komatsu	WA380-7	4.3	20	60	12	35
Komatsu	WA380-7 HL	3.8	16	55	12	35
Komatsu	WA430-6	4.6	20	65	16	35
Komatsu Dresser	538	4	20	60	12	35
Komatsu Dresser	540	4.5	20	60	12	35

For service under chains, or load and carry operations, contact Titan Technical Services.

Pressure and ply recommendations based on normal quarry operations with standard equipment. For different applications, or modified equipment, please contact OTR Field Engineering for a specific recommendation. Tire damage or failure caused by improper load, ply, speed or inflation practices is not covered by the Titan Tire Warranty Policy.

CT - Contact Titan Technical services

HL - High Lift, extended booms, etc.

23.5-25 Loader Usage Chart continued

For Standard Loader Service: <250 ft, < 5 mph

Manufacturer	Model	Bucket	Front	Front	Rear	Rear
			Minimum Ply Rating	Minimum Inflation	Minimum Ply Rating	Minimum Inflation
		Cu.Yd.		Psi		Psi
Liebherr	L550	4.2	16	60	12	35
Liebherr	L550 HL	3.4	16	55	12	35
Liebherr	L556	4.7	20	60	12	35
Liebherr	L556 HL	3.7	20	60	12	35
New Holland	W190B	3.44	16	50	12	35
New Holland	W190B LR	3.44	16	55	12	35
Terex	66C	4	20	60	16	35
Terex	70C	4.4	20	60	16	35
Terex	TL310	4	16	60	12	35
Volvo	L110F	4.4	20	65	16	35
Volvo	L110H	4	16	60	12	35
Volvo	L120B	3.9	16	55	12	35
Volvo	L120C	4.7	20	65	16	35
Volvo	L120D	4.7	20	65	16	40
Volvo	L120F	4.7	24	65	16	40
Volvo	L120H	4.25	20	60	12	35
Volvo	L150	4.5	24	70	16	40
Volvo	L150C	5.2	24	70	16	45
Volvo	L150D	5.2	24	75	20	45

26.5-25 Loader Usage Chart

For Standard Loader Service: <250 ft, < 5 mph

Manufacturer	Model	Bucket	Front	Front	Rear	Rear
			Minimum Ply Rating	Minimum Inflation	Minimum Ply Rating	Minimum Inflation
		Cu.Yd.		Psi		Psi
Caterpillar	966E	5	20	60	20	35
Caterpillar	966F	5	20	60	20	35
Caterpillar	966F-II	5	20	60	20	35
Caterpillar	966G	4.75	20	65	20	35
Caterpillar	966H	5.5	20	65	20	40
Caterpillar	966H	5.75	20	65	20	40
Caterpillar	966K	5.5	20	70	20	40
Caterpillar	966L	5.5	20	65	20	40
Caterpillar	966M	5.5	20	65	20	40
Caterpillar	966M XE	5.5	20	65	20	40
Caterpillar	970F	5.25	20	65	20	40
Caterpillar	972G	5.4	20	65	20	40
Caterpillar	972H	6	26	70	20	40
Caterpillar	972K	5.5	20	70	20	40
Caterpillar	972L	5.5	20	70	20	40
Caterpillar	972M	6	20	65	20	40

For service under chains, or load and carry operations, contact Titan Technical Services.

Pressure and ply recommendations based on normal quarry operations with standard equipment. For different applications, or modified equipment, please contact OTR Field Engineering for a specific recommendation. Tire damage or failure caused by improper load, ply, speed or inflation practices is not covered by the Titan Tire Warranty Policy.

CT - Contact Titan Technical services

HL - High Lift, extended booms, etc.

Load and Inflation Tables

26.5-25 Loader Usage Chart continued

For Standard Loader Service: <250 ft, < 5 mph

Manufacturer	Model	Bucket	Front	Front	Rear	Rear
			Minimum Ply Rating	Minimum Inflation	Minimum Ply Rating	Minimum Inflation
		Cu.Yd.		Psi		Psi
Caterpillar	972M XE	6	26	70	20	40
Case	921	4.75	20	60	20	35
Case	921B	4.75	20	60	20	35
Case	921C	4.75	20	60	20	35
Case	921E	5.75	20	65	20	35
Case	921E XR	5.75	26	70	20	40
Case	921F	4.75	20	55	20	35
Case	921F XR	4.75	20	60	20	35
Daewoo	Mega 400	5.1	20	60	20	35
Daewoo	Mega 400-III	3.9	20	55	20	35
Deere	744E	5	20	60	20	35
Deere	744H	5.25	20	60	20	35
Deere	744H-HL	4.5	20	60	20	35
Deere	744H-MH	5.75	20	70	20	40
Deere	744J	5.25	20	65	20	40
Deere	744J HL	5.25	26	70	20	40
Deere	744K	5.25	20	65	20	35
Deere	744K-HL	5.25	20	70	20	40
Deere	744K-II	5.25	20	65	20	40
Deere	744K-II HL	5.25	26	70	20	40
Deere	824J	6	26	75	20	45
Deere	824J HL	5.25	26	70	20	45
Deere	824K	6	26	70	20	45
Deere	824K-HL	6	26	75	20	45
Deere	824K-II	6	26	75	20	45
Deere	824K-II HL	6	26	75	20	45
Deere	844	6	26	70	20	40
Doosan	DL400	5.1	20	60	20	35
Doosan	DL420-5	5.5	20	65	20	35
Doosan	DL420-5 HL	5.5	26	70	20	40
Doosan	DL450	6.3	26	75	20	45
Doosan	DL450-3	5.88	26	70	20	40
Doosan	DL450-5	6.3	26	75	20	45
Doosan	DL450-5 HL	6.3	26	75	20	45
Fiatallis	FR220	5.1	20	60	20	35
Fiatallis	FR220-2	5	20	60	20	35
Fiat Hitachi	W270	5.2	20	60	20	35
Fiat Hitachi	FR220-2	5	20	60	20	35
Furukawa	FL330-I	4.3	20	55	20	35
Hitachi	ZW310	5.25	20	60	20	35
Hitachi	ZW310 HL	4.75	20	60	20	35
Hyundai	HL770	5	20	65	20	35
Hyundai	HL770-7	5.2	20	65	20	35

For service under chains, or load and carry operations, contact Titan Technical Services.

Pressure and ply recommendations based on normal quarry operations with standard equipment. For different applications, or modified equipment, please contact OTR Field Engineering for a specific recommendation. Tire damage or failure caused by improper load, ply, speed or inflation practices is not covered by the Titan Tire Warranty Policy.

CT - Contact Titan Technical services

HL - High Lift, extended booms, etc.

26.5-25 Loader Usage Chart continued

For Standard Loader Service: <250 ft, < 5 mph

Manufacturer	Model	Bucket Cu.Yd.	Front Minimum Ply Rating	Front Minimum Inflation	Rear Minimum Ply Rating	Rear Minimum Inflation
				Psi		Psi
Hyundai	HL770XTD-7	5.2	20	65	20	40
Hyundai	HL770-7A	5.2	20	65	20	35
Hyundai	HL770XTD-7A	5.2	20	65	20	40
Hyundai	HL770-9	5.5	20	65	20	40
Hyundai	HL770XTD-9	5.5	20	70	20	40
Hyundai	HL770-9A	5.5	20	65	20	40
Hyundai	HL770XTD-9A	5.5	26	70	20	40
Hyundai	HL780-7A	6.7	32	80	20	50
Hyundai	HL780XTD-7A	6.7	32	85	20	50
Hyundai	HL780-9	7.1	32	85	20	50
Hyundai	HL780XTD-9	7.1	32	85	26	55
Hyundai	HL780-9A	7.1	32	85	20	50
Hyundai	HL780XTD-9A	7.1	32	90	26	55
Hyundai	HL970	4.7	20	60	20	35
Hyundai	HL970 XTD	4.7	20	65	20	35
Hyundai	HL980	6.3	32	80	20	50
Hyundai	HL980 XTD	6.3	32	80	20	50
Kawasaki	85Z	4.2	20	55	20	35
Kawasaki	85ZII	4.2	20	55	20	35
Kawasaki	85ZIII	4.3	20	55	20	35
Kawasaki	85ZIV	4.3	20	55	20	35
Kawasaki	85ZIV-2	4.75	20	60	20	35
Kawasaki	85ZV-2	4.8	20	60	20	35
Kawasaki	85Z7	4.8	20	60	20	35
Kawasaki	85Z7 HL	4.8	20	60	20	35
Kawasaki	90ZIII	5	20	60	20	35
Kawasaki	90ZIV	5	20	60	20	35
Kawasaki	90ZIV-2	5.5	20	65	20	40
Kawasaki	90ZV	5.2	20	65	20	35
Kawasaki	90ZV	4.25	20	55	20	35
Kawasaki	90ZV-2	5.2	20	65	20	35
Kawasaki	90Z7	5.5	20	65	20	40
Kawasaki	90Z7 HL	5.5	26	70	20	40
Kawasaki	90Z7B	5.5	20	65	20	40
Kawasaki	90Z7B HL	5.5	26	70	20	40
Kawasaki	92ZV-2	6	26	70	20	45
Kawasaki	92Z7	6.3	26	75	20	45
Kawasaki	92Z7 HL	6.3	32	80	20	50
Kawasaki	95ZV-2	7	32	90	26	55
Komatsu	WA420-1	4.75	20	55	20	35
Komatsu	WA420-3	6	20	65	20	35
Komatsu	WA430-6	4.6	20	55	20	35
Komatsu	WA450-2	5.5	20	65	20	35

For service under chains, or load and carry operations, contact Titan Technical Services.

Pressure and ply recommendations based on normal quarry operations with standard equipment. For different applications, or modified equipment, please contact OTR Field Engineering for a specific recommendation. Tire damage or failure caused by improper load, ply, speed or inflation practices is not covered by the Titan Tire Warranty Policy.

CT - Contact Titan Technical services

HL - High Lift, extended booms, etc.

Load and Inflation Tables

26.5-25 Loader Usage Chart continued

For Standard Loader Service: <250 ft, < 5 mph

Manufacturer	Model	Bucket	Front	Front	Rear	Rear
			Minimum Ply Rating	Minimum Inflation	Minimum Ply Rating	Minimum Inflation
		Cu.Yd.		Psi		Psi
Komatsu	WA450-3	6.8	26	70	20	45
Komatsu	WA470-6	5.5	20	65	20	35
Komatsu	WA470-7	5.5	20	65	20	35
Komatsu	WA470-8	5	20	65	20	40
Komatsu	WA480-6	5.4	20	65	20	40
Komatsu Dresser	542	4.75	20	60	20	35
Komatsu Dresser	545	5.5	26	70	20	40
Komatsu Dresser	550	5.25	20	65	20	35
Liebherr	L566	5.2	20	65	20	35
Liebherr	L566 HL	4.6	20	60	20	35
Liebherr	L580	6.5	26	70	20	45
Liebherr	L580 HL	5.9	26	70	20	40
Terex	80C	5.5	26	70	20	40
Volvo	L150C	5.2	20	60	20	35
Volvo	L150D	5.2	20	65	20	40
Volvo	L150F	5.8	26	70	20	40
Volvo	L150G	6.8	26	75	20	45
Volvo	L150H	5.25	20	65	20	35
Volvo	L180	5.5	20	65	20	40
Volvo	L180C	6	26	70	20	40
Volvo	L180D	6.3	26	75	20	45
Volvo	L180F	6.3	26	75	20	45
Volvo	L180G	7.6	32	85	20	50
Volvo	L180H	5.75	26	75	20	45
Volvo	L190	5.2	20	70	20	40
Volvo	L190B	5.2	20	70	20	40

29.5-25 Loader Usage Chart

For Standard Loader Service: <250 ft, < 5 mph

Manufacturer	Model	Bucket	Front	Front	Rear	Rear
			Minimum Ply Rating	Minimum Inflation	Minimum Ply Rating	Minimum Inflation
		Cu.Yd.		Psi		Psi
Caterpillar	980C	6.75	28	75	28	45
Caterpillar	980F	7	28	75	28	45
Caterpillar	980F-II	7	28	75	28	45
Caterpillar	980G	7	28	75	28	45
Caterpillar	980H	7.5	28	75	28	45
Caterpillar	980K	7.5	28	75	28	45
Caterpillar	980M	7.5	28	75	28	45
Case	1221E	9.2	28	50	28	35
Case	1221E XR	9.2	28	50	28	35
Deere	744J	5.25	28	55	28	35
Deere	744J HL	5.25	28	60	28	35
Deere	824J	6	28	65	28	35
Deere	824J HL	5.25	28	60	28	35
Deere	824K	6	28	65	28	35
Deere	824K HL	6	28	65	28	40
Deere	824K-II	6	28	65	28	35
Deere	824K-II HL	6	28	65	28	40
Deere	844J	7.25	28	75	28	45
Deere	844K	7.25	28	75	28	45
Deere	844K-II	7.25	28	80	28	50
Doosan	DL500	6.8	28	70	28	40
Doosan	DL550-5	7.5	28	80	28	45
Doosan	DL550-5 HL	7.5	34	85	28	50
Furukawa	FL460	6	28	70	28	40

For service under chains, or load and carry operations, contact Titan Technical Services.

Pressure and ply recommendations based on normal quarry operations with standard equipment. For different applications, or modified equipment, please contact OTR Field Engineering for a specific recommendation. Tire damage or failure caused by improper load, ply, speed or inflation practices is not covered by the Titan Tire Warranty Policy.

CT - Contact Titan Technical services

HL - High Lift, extended booms, etc.

Load and Inflation Tables

29.5-25 Loader Usage Chart continued

For Standard Loader Service: <250 ft, < 5 mph

Manufacturer	Model	Bucket	Front	Front	Rear	Rear
			Minimum Ply Rating	Minimum Inflation	Minimum Ply Rating	Minimum Inflation
		Cu.Yd.		Psi		Psi
Hyundai	HL780-7A	6.7	28	70	28	40
Hyundai	HL780XTD-7A	6.7	28	70	28	45
Hyundai	HL780-9	7.1	28	70	28	45
Hyundai	HL780XTD-9	7.1	28	75	28	45
Hyundai	HL780-9A	7.1	28	75	28	45
Hyundai	HL780XTD-9A	7.1	28	75	28	45
Hyundai	HL980	6.3	28	70	28	40
Hyundai	HL980 XTD	6.3	28	70	28	45
Kawasaki	95Z	6	28	65	28	40
Kawasaki	95ZII	6	28	65	28	40
Kawasaki	95ZIII	6.5	28	70	28	40
Kawasaki	95ZIV	6.5	28	70	28	40
Kawasaki	95ZIV-2	7.25	28	75	28	45
Kawasaki	95ZIV-3	7.25	28	75	28	45
Kawasaki	95ZV-2	7	28	75	28	45
Kawasaki	95Z7	7.3	34	80	28	50
Kawasaki	95Z7 HL	7.3	34	85	28	50
Komatsu	WA500-1	6	28	65	28	40
Komatsu	WA500-3	7.2	28	70	28	45
Komatsu	WA500-6	7.3	28	80	28	50
Komatsu	WA500-7	7.3	28	80	28	50
Komatsu	WA500-7 HL	5.9	28	70	28	40
Komatsu	WA500-7 Steel Mill	5.25	28	70	28	45
Komatsu Dresser	555	6	28	70	28	40
Komatsu Dresser	558	6	28	65	28	40
Volvo	L190	5.2	28	60	28	35
Volvo	L190B	5.2	28	60	28	35
Volvo	L220D	7	28	70	28	40
Volvo	L220E	7.1	28	75	28	45
Volvo	L220F	7.8	28	80	28	50
Volvo	L220G	8.2	34	85	28	50
Volvo	L220H	6.8	28	75	28	45

725/70-25 Loader Usage Chart

For Standard Loader Service: <250 ft, < 5 mph

Manufacturer	Model	Bucket	Front	Front	Rear	Rear
			Minimum Ply Rating	Minimum Inflation	Minimum Ply Rating	Minimum Inflation
		Cu.Yd.		Psi		Psi
Caterpillar	950K	3.5	16	50	16	35
Caterpillar	950K HL	3.5	16	50	16	35
Caterpillar	950M	4	16	55	16	35
Caterpillar	950M HL	4	CT	CT	16	35
Deere	644K	4.25	16	50	16	35
Deere	644K HL	4.25	16	55	16	35

For service under chains, or load and carry operations, contact Titan Technical Services.

Pressure and ply recommendations based on normal quarry operations with standard equipment. For different applications, or modified equipment, please contact OTR Field Engineering for a specific recommendation. Tire damage or failure caused by improper load, ply, speed or inflation practices is not covered by the Titan Tire Warranty Policy.

CT - Contact Titan Technical services

HL - High Lift, extended booms, etc.

Load and Inflation Tables

35/65-33 Loader Usage Chart

For Standard Loader Service: < 250 ft, < 5 mph

Pit Loader Application						
Manufacturer	Model	Bucket	Front Minimum Ply Rating	Front Minimum Inflation	Rear Minimum Ply Rating	Rear Minimum Inflation
		Cu.Yd.		Psi		Psi
Caterpillar	986H	6.12	42	85	42	50
Caterpillar	986H HL	5.35	42	80	42	50
Caterpillar	988B	8.25	42	105	42	65
Caterpillar	988F	7.75	42	100	42	65
Caterpillar	988G	8	CT	CT	42	70
Caterpillar	988H	8.2	CT	CT	42	75
Caterpillar	988H	8.33	CT	CT	42	75
Caterpillar	988H	9.2	CT	CT	42	80
Caterpillar	988H HL	8.33	CT	CT	42	75
Caterpillar	988K	8.4	CT	CT	42	75
Caterpillar	988K HL	8.4	CT	CT	42	75
Kawasaki	110Z	7.5	42	95	42	60
Kawasaki	110ZII	7.5	42	95	42	60
Kawasaki	115ZIII	7.5	42	95	42	60
Kawasaki	115ZIV	7.5	42	100	42	65
Kawasaki	115ZIV-2	8.25	42	105	42	70
Kawasaki	115ZV	7.5	42	100	42	65
Kawasaki	115ZV-2	7.8	42	105	42	65
Kawasaki	115ZV-2 HL	6.5	42	95	42	60
Kawasaki	115Z7	8.3	42	105	42	65
Kawasaki	115Z7 HL	9	CT	CT	42	75
Kawasaki	115Z7 Xtreme	9.15	42	110	42	70
Komatsu	WA600-1	7.1	42	90	42	55
Komatsu	WA600-3	8	42	95	42	60
Komatsu	WA600-6	8.4	CT	CT	42	75
Komatsu	WA600-6	9.2	CT	CT	42	80
Komatsu Dresser	568	7.5	42	95	42	60
O&K	7500	7	42	90	42	55
Sandvik	LH621-10	10.5	CT	CT	42	75
Terex	90C	8.5	42	105	42	65
Volvo	L320	8	42	100	42	65
Volvo	L330C	8.6	42	110	42	70
Volvo	L330D	8.6	42	110	42	70
Volvo	L330E	8.6	CT	CT	42	70
Volvo	L350F	10.1	CT	CT	42	80

Yard Loader Application						
Manufacturer	Model	Bucket	Front Minimum Ply Rating	Front Minimum Inflation	Rear Minimum Ply Rating	Rear Minimum Inflation
		Cu.Yd.		Psi		Psi
Caterpillar	986H	6.12	42	75	42	45
Caterpillar	986H HL	5.35	42	70	42	45
Caterpillar	988B	8.25	42	90	42	55
Caterpillar	988F	7.75	42	90	42	55
Caterpillar	988G	8	42	95	42	60
Caterpillar	988H	8.2	42	100	42	65
Caterpillar	988H	8.33	42	100	42	65
Caterpillar	988H	9.2	42	105	42	65
Caterpillar	988H HL	8.33	42	100	42	60
Caterpillar	988K	8.4	42	100	42	65
Caterpillar	988K HL	8.4	42	100	42	65
Kawasaki	110Z	7.5	42	80	42	50
Kawasaki	110ZII	7.5	42	80	42	50
Kawasaki	115ZIII	7.5	42	80	42	50
Kawasaki	115ZIV	7.5	42	85	42	55
Kawasaki	115ZIV-2	8.25	42	90	42	60
Kawasaki	115ZV	7.5	42	85	42	55
Kawasaki	115ZV-2	7.8	42	90	42	55
Kawasaki	115ZV-2 HL	6.5	42	80	42	50
Kawasaki	115Z7	8.3	42	90	42	55
Kawasaki	115Z7 HL	9	42	95	42	60
Kawasaki	115Z7 Xtreme	9.15	42	90	42	60
Komatsu	WA600-1	7.1	42	75	42	45
Komatsu	WA600-3	8	42	80	42	50
Komatsu	WA600-6	8.4	42	95	42	60
Komatsu	WA600-6	9.2	42	85	42	55
Komatsu Dresser	568	7.5	42	80	42	50
O&K	7500	7	42	80	42	50
Sandvik	LH621-10	10.5	CT	CT	42	75
Terex	90C	8.5	42	90	42	55
Volvo	L320	8	42	90	42	55
Volvo	L330C	8.6	42	95	42	60
Volvo	L330D	8.6	42	95	42	60
Volvo	L330E	8.6	42	95	42	60
Volvo	L350F	10.1	42	105	42	65

45/65-45 Loader Usage Chart

For Standard Loader Service: < 250 ft, < 5 mph

Manufacturer	Model	Bucket	Front Minimum Ply Rating	Front Minimum Inflation	Rear Minimum Ply Rating	Rear Minimum Inflation
Caterpillar	992B	10	58	80	58	45
Caterpillar	992C	12.5	58	105	58	70
Caterpillar	992C HL	12.5	58	115	58	75
Caterpillar	992D	14	58	110	58	70
Caterpillar	992D HL	14	58	120	58	75
Caterpillar	992G	16	58	CT	58	85
Caterpillar	992G HL	16	CT	CT	58	90
Caterpillar	992K	14	58	115	58	75
Caterpillar	992K HL	14	58	110	58	70
Komatsu	WA800-2	13.7	58	105	58	70
Komatsu	WA800-3	14.4	58	115	58	75
Komatsu	WA900-3	17	58	CT	58	80
Komatsu	WA900-3 HL	15	CT	CT	58	85
LeTourneau	L-950-2	18	CT	CT	58	90
LeTourneau	L-950-2 HL	16	CT	CT	58	85
LeTourneau	L1000	17	58	CT	58	80

41.25/70-39 Loader Usage Chart

For Standard Loader Service: < 250 ft, < 5 mph

Manufacturer	Model	Bucket	Front Minimum Ply Rating	Front Minimum Inflation	Rear Minimum Ply Rating	Rear Minimum Inflation
Caterpillar	990	11	42	90	42	55
Caterpillar	990H	11.25	CT	CT	42	65
Caterpillar	990K	11.25	CT	CT	42	65
Caterpillar	990K HL	11.25	CT	CT	42	70
Kawasaki	135ZV-2	12.8	CT	CT	42	65
Kawasaki	135ZV-2 HL	11.5	42	95	42	60
Komatsu	WA700-1	11.1	42	85	42	50
Volvo	L480B	12.5	CT	CT	42	65

For service under chains, or load and carry operations, contact Titan Technical Services.

Pressure and ply recommendations based on normal quarry operations with standard equipment. For different applications, or modified equipment, please contact OTR Field Engineering for a specific recommendation. Tire damage or failure caused by improper load, ply, speed or inflation practices is not covered by the Titan Tire Warranty Policy.

CT - Contact Titan Technical services

HL - High Lift, extended booms, etc.

18.00-25 Rigid Truck Usage Chart

For Standard Earthmover Service: <2.5 mile, < 30 mph

Manufacturer	Model	Payload	Front Minimum Ply Rating	Front Minimum Inflation	Rear Minimum Ply Rating	Rear Minimum Inflation
		Tons		Psi		Psi
Euclid	R32 w/ liners	34	40	85	40	95
Euclid	R32 w/o liners	36	40	85	40	95
International	350B (Detroit)	50	40	95	CT	CT
International	350B (Cummins)	50	CT	CT	CT	CT

18.00-33 Rigid Truck Usage Chart

For Standard Earthmover Service: <2.5 mile, < 30 mph

Manufacturer	Model	Payload	Front Minimum Ply Rating	Front Minimum Inflation	Rear Minimum Ply Rating	Rear Minimum Inflation
		Tons		Psi		Psi
Astra	RD 40C	44.1	CT	CT	CT	CT
Caterpillar	769B	35	32	85	32	80
Caterpillar	769C	40	CT	CT	CT	CT
Caterpillar	769D	35	CT	CT	CT	CT
Caterpillar	770	40	CT	CT	CT	CT
Caterpillar	770F	49	CT	CT	CT	CT
Caterpillar	770G	50	CT	CT	CT	CT
Caterpillar	771C Quarry	44	CT	CT	CT	CT
Caterpillar	771D	45	CT	CT	CT	CT
Hitachi	EH650	40	32	80	CT	CT
Hitachi	EH700	42	CT	CT	CT	CT
Hitachi	EH750	42.5	CT	CT	CT	CT
Hitachi	EH750-3	46.2	CT	CT	CT	CT
Euclid	R35	35	CT	CT	CT	CT
Euclid	R36	40	32	80	CT	CT
Euclid	R40	41.5	CT	CT	CT	CT
Euclid	R40C	41.9	CT	CT	CT	CT
Komatsu	HD325-3	35	32	75	32	80
Komatsu	HD325-5	35	32	75	32	85
Komatsu	HD325-6 Quarry	44	CT	CT	CT	CT
Komatsu	HD325-6 4WD	35	CT	CT	CT	CT
Komatsu	HD325-6	44	CT	CT	CT	CT
Komatsu	HD325-7	40	CT	CT	CT	CT
Komatsu	HD405-7	45.2	CT	CT	CT	CT
Komatsu Haulpak	140M	40	CT	CT	CT	CT
Perlini	DP 405 WD	44.1	CT	CT	CT	CT
Terex	3340	40	CT	CT	CT	CT

Pressure and ply recommendations based on normal quarry operations with standard equipment. For different applications, or modified equipment, please contact OTR Field Engineering for a specific recommendation. Tire damage or failure caused by improper load, ply, speed or inflation practices is not covered by the Titan Tire Warranty Policy.

CT - Contact Titan Technical services

Load and Inflation Tables

21.00-35 Rigid Truck Usage Chart

For Standard Earthmover Service: <2.5 mile, < 30 mph

Manufacturer	Model	Payload	Front Minimum Ply Rating	Front Minimum Inflation	Rear Minimum Ply Rating	Rear Minimum Inflation
		Tons		Psi		Psi
Caterpillar	773	50	42	95	42	90
Caterpillar	773B	58	CT	CT	CT	CT
Dart	2085	85	36	70	42	90
Euclid	R50	58.1	CT	CT	CT	CT
Komatsu	HD460-1	51	42	85	42	95
Terex	3345	45	42	85	36	80
Terex	3307	49	42	85	42	85
Terex	3308E	55	CT	CT	CT	CT
Terex	TR45	45	42	85	42	85

24.00-35 Rigid Truck Usage Chart

For Standard Earthmover Service: <2.5 mile, < 30 mph

Manufacturer	Model	Payload	Front Minimum Ply Rating	Front Minimum Inflation	Rear Minimum Ply Rating	Rear Minimum Inflation
		Tons		Psi		Psi
Caterpillar	773	50	42	65	42	65
Caterpillar	773B	58	42	75	42	75
Caterpillar	773D	50	42	75	42	75
Caterpillar	773E	60	42	80	42	85
Caterpillar	773F	61	48	90	42	80
Caterpillar	773G	54	42	75	42	75
Caterpillar	773G-4T	69.3	48	90	42	85
Caterpillar	775B Quarry	65	42	85	42	85
Caterpillar	775D	65	42	85	48	95
Caterpillar	775E	70	42	85	CT	CT
Caterpillar	775F	70	48	95	48	95
Caterpillar	775G	70	CT	CT	CT	CT
Caterpillar	775G-4T	78.8	CT	CT	48	95
Dart	2085	85	42	50	42	65
Euclid	R50	58.1	42	75	42	75
Euclid	R60	63.1	42	75	42	80
Euclid	R60C	66	48	95	42	80
Euclid	R65	69.2	42	85	48	85
Euclid	R65C	71.1	48	90	48	95
Euclid	R75	75	CT	CT	48	95
Hitachi	EH 1000	66	42	85	48	85
Hitachi	EH 1100	72.3	48	90	48	95
Hitachi	EH 1100-3	71.5	48	90	CT	CT
Hitachi	EH1100-5	70	CT	CT	48	90
Komatsu	HD465-3	51	42	65	42	70
Komatsu	HD465-5	61	42	65	42	70

Pressure and ply recommendations based on normal quarry operations with standard equipment. For different applications, or modified equipment, please contact OTR Field Engineering for a specific recommendation. Tire damage or failure caused by improper load, ply, speed or inflation practices is not covered by the Titan Tire Warranty Policy.

CT - Contact Titan Technical services

Load and Inflation Tables

24.00-35 Rigid Truck Usage Chart continued

For Standard Earthmover Service: <2.5 mile, < 30 mph

Manufacturer	Model	Payload	Front Minimum Ply Rating	Front Minimum Inflation	Rear Minimum Ply Rating	Rear Minimum Inflation
		Tons		Psi		Psi
Komatsu	HD465-5 Quarry	66	48	85	48	95
Komatsu	HD465-7	61	42	80	42	85
Komatsu	HD605-7	70	48	90	CT	CT
Komatsu-Haulpak	210M	60	42	80	42	80
Perlini	DP705 WD	71.6	48	90	48	95
Terex	3308E	55	42	75	42	75
Terex	3309	55	42	80	42	80
Terex	3310E	66	48	90	48	90
Terex	TR60	60	42	80	42	80
Terex	TR70	72	CT	CT	CT	CT

24.00-49 Rigid Truck Usage Chart

For Standard Earthmover Service: <2.5 mile, < 30 mph

Manufacturer	Model	Payload	Front Minimum Ply Rating	Front Minimum Inflation	Rear Minimum Ply Rating	Rear Minimum Inflation
		Tons		Psi		Psi
Euclid	R85	85	48	90	CT	CT
Euclid	R85B	90	CT	CT	CT	CT

27.00-49 Rigid Truck Usage Chart

For Standard Earthmover Service: <2.5 mile, < 30 mph

Manufacturer	Model	Payload	Front Minimum Ply Rating	Front Minimum Inflation	Rear Minimum Ply Rating	Rear Minimum Inflation
		Tons		Psi		Psi
Caterpillar	777	85	48	75	48	75
Caterpillar	777B	95	48	80	48	85
Caterpillar	777C	95	48	85	48	85
Caterpillar	777D	100	CT	CT	CT	CT
Caterpillar	777F	100	CT	CT	CT	CT
Caterpillar	777G	100	CT	CT	CT	CT
Euclid	R85B	85	48	85	48	85
Euclid	R90	95.7	48	85	CT	CT
Euclid	R90C	100	CT	CT	CT	CT
Euclid	R100	100	CT	CT	CT	CT
Hitachi	EH1600	98.9	CT	CT	CT	CT
Hitachi	EH1700	108.4	CT	CT	CT	CT
Hitachi	EH1700-3	100	CT	CT	CT	CT
Komatsu	HD785-1	86	48	70	48	75
Komatsu	HD785-3	86	48	75	48	80
Komatsu	HD785-3	100	48	80	CT	CT
Komatsu	HD785-5	106	CT	CT	CT	CT
Komatsu	HD785-7	100	CT	CT	CT	CT

Pressure and ply recommendations based on normal quarry operations with standard equipment. For different applications, or modified equipment, please contact OTR Field Engineering for a specific recommendation. Tire damage or failure caused by improper load, ply, speed or inflation practices is not covered by the Titan Tire Warranty Policy.

CT - Contact Titan Technical services

Load and Inflation Tables

27.00-49 Rigid Truck Usage Chart continued

For Standard Earthmover Service: <2.5 mile, < 30 mph

Manufacturer	Model	Payload	Front Minimum Ply Rating	Front Minimum Inflation	Rear Minimum Ply Rating	Rear Minimum Inflation
		Tons		Psi		Psi
Komatsu Haulpak	325M	95	48	85	48	85
Komatsu Haulpak	330M	100	CT	CT	CT	CT
Kress	CH160	160	CT	CT	CT	CT
Kress	CH180	180	CT	CT	CT	CT
Perlini	DP905	104.7	CT	CT	CT	CT
Rimpull	RD100	100	48	85	CT	CT
Rimpull	RD100C	100	48	85	CT	CT
Terex	3311C	85	48	75	48	70
Terex	3311D	77	48	85	48	75
Terex	3311E	94	CT	CT	48	80
Terex	TR100	100	CT	CT	CT	CT
Terex	TR100 (HR)	93.55	CT	CT	CT	CT
Terex	TR100D	100	CT	CT	CT	CT
Unit Rig	Dart 3100	100	CT	CT	CT	CT
Unit Rig	Dart 4160	160	48	60	CT	CT
Unit Rig	M85	85	48	70	48	70
Unit Rig	M100	100	CT	CT	CT	CT
Unit Rig	M120-15	120	CT	CT	CT	CT
Unit Rig	Mark 24	85	48	85	48	70

30.00-51 Rigid Truck Usage Chart

For Standard Earthmover Service: <2.5 mile, < 30 mph

Manufacturer	Model	Payload	Front Minimum Ply Rating	Front Minimum Inflation	Rear Minimum Ply Rating	Rear Minimum Inflation
		Tons		Psi		Psi
Euclid	R100	100	52	70	52	70
Euclid	R120E	120	CT	CT	CT	CT

Pressure and ply recommendations based on normal quarry operations with standard equipment. For different applications, or modified equipment, please contact OTR Field Engineering for a specific recommendation. Tire damage or failure caused by improper load, ply, speed or inflation practices is not covered by the Titan Tire Warranty Policy.

CT - Contact Titan Technical services

33.00-51 Rigid Truck Usage Chart

For Standard Earthmover Service: <2.5 mile, < 30 mph

Manufacturer	Model	Payload	Front Minimum Ply Rating	Front Minimum Inflation	Rear Minimum Ply Rating	Rear Minimum Inflation
		Tons		Psi		Psi
Belaz	75131	143	CT	CT	CT	CT
Belaz	75137NA	143	CT	CT	CT	CT
Caterpillar	785	155	CT	CT	CT	CT
Caterpillar	785B	155	CT	CT	CT	CT
Caterpillar	785C	150	CT	CT	CT	CT
Caterpillar	785D	146	CT	CT	CT	CT
Euclid	R120E	120	58	70	58	75
Euclid	R130	152	CT	CT	CT	CT
Euclid	R130B	146	CT	CT	CT	CT
Euclid	R130M	130	58	70	58	80
Euclid	R150	150	CT	CT	CT	CT
Komatsu Haulpak	510E	150	CT	CT	CT	CT
Komatsu Haulpak	530M	165	CT	CT	CT	CT
Komatsu	HD1500-7	160	CT	CT	CT	CT
Terex	MT3300	150	CT	CT	CT	CT
Terex	MT3300AC	150	CT	CT	CT	CT
Terex	MT3314B	125	58	80	58	75

Pressure and ply recommendations based on normal quarry operations with standard equipment. For different applications, or modified equipment, please contact OTR Field Engineering for a specific recommendation. Tire damage or failure caused by improper load, ply, speed or inflation practices is not covered by the Titan Tire Warranty Policy.

CT - Contact Titan Technical services

Load and Inflation Tables

20.5-25 Towed Scraper Usage Chart

For Standard Scraper Service: <2.5 mile, < 30 mph

Manufacturer	Model	Payload	Tires Per Axle	Tire Minimum Ply Rating	Tire Minimum Inflation
		Cu. Yd.			Psi
Ashland	110TS2	11.3	2	CT	CT
Ashland	110XL2	11	2	CT	CT
Ashland	130TS2	13	2	CT	CT
Ashland	220TS4	22	4	CT	CT
Ashland	2014CS	20	6	16	40
Deere	1510DC	15	4	16	40
Deere	1612DE	16	4	24	50
Deere	1810DC	18	4	24	50
Deere	1812DC	18	4	20	50
Deere	1814DC	18	6	16	30
Deere	2010DE	20	4	CT	CT
Deere	2014DE	20	6	16	40

23.5-25 Towed Scraper Usage Chart

For Standard Scraper Service: <2.5 mile, < 30 mph

Manufacturer	Model	Payload	Tires Per Axle	Tire Minimum Ply Rating	Tire Minimum Inflation
		Cu. Yd.			Psi
Caterpillar	TS185	19	4	20	35
Deere	2112DC	21.5	6	12	30
Deere	2412DE	24	4	CT	CT
K-Tec	1228	28	4	CT	CT
K-Tec	1233	33	4	CT	CT
K-Tec	1236	36	4	CT	CT

26.5-25 Towed Scraper Usage Chart

For Standard Scraper Service: <2.5 mile, < 30 mph

Manufacturer	Model	Payload	Tires Per Axle	Tire Minimum Ply Rating	Tire Minimum Inflation
		Cu. Yd.			Psi
Caterpillar	TS185	19	4	20	30
Caterpillar	TS225	23.5	4	20	35
Deere	2112DC (1)	21.5	4	32	55
Deere	2112DC (2)	21.5	4	20	35
Deere	2412DE (1)	24	4	44	60
Deere	2412DE (2)	24	4	26	45
K-Tec	1233	33	4	32	50

Pressure and ply recommendations based on normal quarry operations with standard equipment. For different applications, or modified equipment, please contact OTR Field Engineering for a specific recommendation. Tire damage or failure caused by improper load, ply, speed or inflation practices is not covered by the Titan Tire Warranty Policy.

CT - Contact Titan Technical services

(1)- Front scraper used in train

(2)- Rear scraper used in train, or single scraper

Load and Inflation Tables

29.5-25 Towed Scraper Usage Chart

For Standard Scraper Service: <2.5 mile, < 30 mph

Manufacturer	Model	Payload	Tires Per Axle	Tire Minimum Ply Rating	Tire Minimum Inflation
		Cu. Yd.			Psi
Ashland	155TS2	15.5	2	28	45
Ashland	215TS2	21.5	2	34	60
Caterpillar	TS180	19	2	34	50
Deere	2010DE	20	2	34	55

18.00-25 Tractor Scraper Usage Chart

For Standard Earthmover Service: <2.5 mile, < 30 mph

Manufacturer	Model	Payload	Front Minimum Ply Rating	Front Minimum Inflation	Rear Minimum Ply Rating	Rear Minimum Inflation
		Cu. Yd.		Psi		Psi
Caterpillar	613C II	11	32	60	32	65

23.5-25 Tractor Scraper Usage Chart

For Standard Earthmover Service: <2.5 mile, < 30 mph

Manufacturer	Model	Payload	Front Minimum Ply Rating	Front Minimum Inflation	Rear Minimum Ply Rating	Rear Minimum Inflation
		Cu. Yd.		Psi		Psi
Caterpillar	613B	11	20	35	20	40
Caterpillar	613C	11	20	40	20	40
Caterpillar	613C II	11	20	40	20	40
Caterpillar	613G	11	CT	CT	20	40
Deere	762	11	20	40	20	40
Deere	762A	11	20	45	20	40
Deere	762B	11	20	45	20	40
Deere	762B II	11	20	45	20	40
Komatsu Dresser	412	11	20	40	20	40
Komatsu Dresser	412B	11	20	40	20	40

26.5-25 Tractor Scraper Usage Chart

For Standard Earthmover Service: <2.5 mile, < 30 mph

Manufacturer	Model	Payload	Front Minimum Ply Rating	Front Minimum Inflation	Rear Minimum Ply Rating	Rear Minimum Inflation
		Cu. Yd.		Psi		Psi
Caterpillar	611	15	32	55	32	50
Caterpillar	611C II	15	44	70	32	50
Caterpillar	615	16	32	60	32	50
Caterpillar	615C	16	32	60	32	50
Caterpillar	615C II	17	44	60	32	55
Deere	860	15	26	45	26	45
Deere	860A Std	15	32	50	26	45
Deere	860A HD	15	32	50	26	50
Deere	862	16	32	55	32	55
Deere	862B	16	32	55	32	55
Fiat Allis	161	15	26	45	26	45

Pressure and ply recommendations based on normal quarry operations with standard equipment. For different applications, or modified equipment, please contact OTR Field Engineering for a specific recommendation. Tire damage or failure caused by improper load, ply, speed or inflation practices is not covered by the Titan Tire Warranty Policy.

CT - Contact Titan Technical services

Load and Inflation Tables

29.5-25 Tractor Scraper Usage Chart

For Standard Scraper Service: <2.5 mile, < 30 mph

Manufacturer	Model	Payload	Front Minimum Ply Rating	Front Minimum Inflation	Rear Minimum Ply Rating	Rear Minimum Inflation
		Cu. Yd.		Psi		Psi
Caterpillar	611	15	28	45	28	40
Caterpillar	611C II	15	28	45	28	40
Caterpillar	615	16	28	45	28	40
Caterpillar	615C	16	28	45	28	40
Caterpillar	615C II	17	28	50	28	45
Deere	862 w/ Kress bowl	18	28	45	28	45
Deere	862 w/ Kress bowl	20	28	50	34	50
Deere	862B	16	28	45	28	45
Fiat Allis	161	15	28	40	28	40
Terex	TS14B	20	34	55	34	50
Terex	TS14C	20	34	55	34	50
Terex	TS14G	20	34	60	34	55

29.5-29 Tractor Scraper Usage Chart

For Standard Scraper Service: <2.5 mile, < 30 mph

Manufacturer	Model	Payload	Front Minimum Ply Rating	Front Minimum Inflation	Rear Minimum Ply Rating	Rear Minimum Inflation
		Cu. Yd.		Psi		Psi
Caterpillar	621B	20	38	60	28	50
Caterpillar	621E	20	34	60	34	50
Caterpillar	621G	22	CT	CT	34	60
Caterpillar	623B	22	CT	CT	34	55
Caterpillar	623E	23	CT	CT	38	60
Caterpillar	623F	23	CT	CT	CT	CT
Caterpillar	627B	20	34	60	38	60
Caterpillar	627E	20	34	60	38	65
Caterpillar	627G	22	38	65	CT	CT
Fiatalis	261B	23	38	60	34	60
Fiatalis	262B	21	38	60	34	60
Fiatalis	263B	23	38	65	CT	CT
Komatsu Dresser	431B	21	34	55	28	50
Komatsu Dresser	433B	21	34	55	34	60
Komatsu Dresser	442B	22	38	60	34	55
Komatsu Dresser	444B	22	38	65	CT	CT
Terex	S23E	23	38	60	34	55

Pressure and ply recommendations based on normal quarry operations with standard equipment. For different applications, or modified equipment, please contact OTR Field Engineering for a specific recommendation. Tire damage or failure caused by improper load, ply, speed or inflation practices is not covered by the Titan Tire Warranty Policy.

CT - Contact Titan Technical services

33.25-29 Tractor Scraper Usage Chart

For Standard Scraper Service: <2.5 mile, < 30 mph

Manufacturer	Model	Payload	Front Minimum Ply Rating	Front Minimum Inflation	Rear Minimum Ply Rating	Rear Minimum Inflation
		Cu. Yd.		Psi		Psi
Caterpillar	621B	20	32	45	32	35
Caterpillar	621E	20	34	45	34	40
Caterpillar	621F	20	34	45	34	40
Caterpillar	621G	20	38	50	34	45
Caterpillar	621G	22	38	50	34	45
Caterpillar	621H	24	38	55	34	50
Caterpillar	621K	24	38	55	34	50
Caterpillar	621K P/P	24	38	55	34	50
Caterpillar	623F	23	38	55	38	55
Caterpillar	623G	23	38	55	38	55
Caterpillar	623H	23	38	60	38	50
Caterpillar	623K	23	CT	CT	38	50
Caterpillar	627B	20	34	45	34	45
Caterpillar	627E	20	34	45	34	50
Caterpillar	627F	20	34	50	38	50
Caterpillar	627G	22	38	55	38	50
Caterpillar	627H	24	CT	CT	CT	CT
Caterpillar	627K	24	CT	CT	38	55
Caterpillar	627K P/P	24	CT	CT	38	55

33.5-33 Tractor Scraper Usage Chart

For Standard Scraper Service: <2.5 mile, < 30 mph

Manufacturer	Model	Payload	Front Minimum Ply Rating	Front Minimum Inflation	Rear Minimum Ply Rating	Rear Minimum Inflation
		Cu. Yd.		Psi		Psi
Terex	TS24	33	44	55	44	65
Terex	TS36	40	CT	CT	CT	CT
Terex	TS40	50	CT	CT	CT	CT

37.5-33 Tractor Scraper Usage Chart

For Standard Scraper Service: <2.5 mile, < 30 mph

Manufacturer	Model	Payload	Front Minimum Ply Rating	Front Minimum Inflation	Rear Minimum Ply Rating	Rear Minimum Inflation
		Cu. Yd.		Psi		Psi
Terex	TS24B	34	54	60	54	60
Terex	S24B	34	54	60	54	55
Terex	TS38B	41	54	70	54	65

Pressure and ply recommendations based on normal quarry operations with standard equipment. For different applications, or modified equipment, please contact OTR Field Engineering for a specific recommendation. Tire damage or failure caused by improper load, ply, speed or inflation practices is not covered by the Titan Tire Warranty Policy.

CT - Contact Titan Technical services

Load and Inflation Tables

29.5-35 Tractor Scraper Usage Chart

For Standard Scraper Service: <2.5 mile, < 30 mph

Manufacturer	Model	Payload	Front Minimum Ply Rating	Front Minimum Inflation	Rear Minimum Ply Rating	Rear Minimum Inflation
		Cu. Yd.		Psi		Psi
Caterpillar	621B	20	34	55	34	45
Caterpillar	621E	20	34	55	34	45
Caterpillar	623B	23	CT	CT	34	50
Caterpillar	623E	23	CT	CT	34	55
Caterpillar	627B	20	34	55	34	55
Caterpillar	627E	20	34	55	34	60
Terex	S23E	23	34	55	34	50

33.25-35 Tractor Scraper Usage Chart

For Standard Scraper Service: <2.5 mile, < 30 mph

Manufacturer	Model	Payload	Front Minimum Ply Rating	Front Minimum Inflation	Rear Minimum Ply Rating	Rear Minimum Inflation
		Cu. Yd.		Psi		Psi
Caterpillar	631D	31	56	70	38	60
Caterpillar	631E	31	56	75	44	60
Caterpillar	633D	34	56	75	56	75
Caterpillar	637D	31	56	70	56	70
Caterpillar	637E	31	56	75	56	75

37.25-35 Tractor Scraper Usage Chart

For Standard Scraper Service: <2.5 mile, < 30 mph

Manufacturer	Model	Payload	Front Minimum Ply Rating	Front Minimum Inflation	Rear Minimum Ply Rating	Rear Minimum Inflation
		Cu. Yd.		Psi		Psi
Caterpillar	631D	31	CT	CT	36	45
Caterpillar	631E	31	CT	CT	36	45
Caterpillar	631E II	31	CT	CT	36	45
Caterpillar	631G	34	CT	CT	CT	CT
Caterpillar	631K	34	CT	CT	CT	CT
Caterpillar	631K P/P	34	CT	CT	CT	CT
Caterpillar	633D	34	CT	CT	CT	CT
Caterpillar	633E	34	CT	CT	CT	CT
Caterpillar	633E II	34	CT	CT	CT	CT
Caterpillar	637D	31	CT	CT	CT	CT
Caterpillar	637E	31	CT	CT	CT	CT
Caterpillar	637E II	31	CT	CT	CT	CT
Caterpillar	637G	34	CT	CT	CT	CT
Caterpillar	637G P/P	34	CT	CT	CT	CT
Caterpillar	637K	34	CT	CT	CT	CT
Caterpillar	637K P/P	34	CT	CT	CT	CT
Caterpillar	657G	44	CT	CT	CT	CT
Caterpillar	657G P/P	44	CT	CT	CT	CT

Pressure and ply recommendations based on normal quarry operations with standard equipment. For different applications, or modified equipment, please contact OTR Field Engineering for a specific recommendation. Tire damage or failure caused by improper load, ply, speed or inflation practices is not covered by the Titan Tire Warranty Policy.

CT - Contact Titan Technical services

Load and Inflation Tables

20.5R25 Articulated Truck Usage Chart

For Standard Earthmover Service: < 2.5 mi, < 30 mph

Manufacturer	Model	Payload	Front Minimum Load Rating	Front Minimum Inflation	Middle Minimum Load Rating	Middle Minimum Inflation	Rear Minimum Load Rating	Rear Minimum Inflation
		Tons		Psi		Psi		Psi
Bell	B20B	20	1*	45	2*	55	2*	55
Bell	B20D 6x4	18	1*	40	2*	65	2*	60
Bell	B20D 6x6	18	1*	40	2*	65	2*	65
Caterpillar	D250B	25	2*	70	2*	75	2*	75
Caterpillar	D250D	25	2*	60	2*	75	2*	75
Komatsu	HA250-1	25	2*	75	2*	75	2*	75
Moxy	MT30 LHS	30	CT	CT	CT	CT	CT	CT
Terex	2364	23	2*	70	2*	65	2*	60
Terex	2366	23	2*	70	2*	65	2*	65
Terex	2566B	25	CT	CT	2*	70	2*	70
Terex	2566C	25	CT	CT	2*	75	2*	70
Volvo	A20 6X4	20	CT	-	2*	60	2*	60
Volvo	A20 6x6	20	CT	-	2*	60	2*	60
Volvo	A20C 6X6	20	1*	50	2*	60	2*	60
Volvo	A25 6X4	25	1*	55	2*	75	2*	75
Volvo	A25	25	2*	55	2*	75	2*	75
Volvo	A25B	25	1*	55	2*	75	2*	75

23.5R25 Articulated Truck Usage Chart

For Standard Earthmover Service: < 2.5 mi, < 30 mph

Manufacturer	Model	Payload	Front Minimum Load Rating	Front Minimum Inflation	Middle Minimum Load Rating	Middle Minimum Inflation	Rear Minimum Load Rating	Rear Minimum Inflation
		Tons		Psi		Psi		Psi
Bell	B25B	25	1*	50	1*	50	1*	50
Bell	B25D	26	1*	50	2*	55	2*	55
Bell	B25E	27	1*	45	2*	65	2*	65
Bell	B30B	30	2*	60	2*	70	2*	70
Bell	B30D	30	1*	50	2*	65	2*	65
Bell	B30E	31	1*	50	2*	75	2*	75
Caterpillar	D20D	20	2*	60	1*	40	2*	75
Caterpillar	D250B	25	1*	50	1*	55	1*	55
Caterpillar	D250D	25	1*	45	1*	55	1*	55
Caterpillar	D250E	25	1*	55	2*	65	2*	65
Caterpillar	D300B	30	2*	60	2*	65	2*	65
Caterpillar	D300D	30	2*	55	2*	70	2*	70
Caterpillar	D300E	30	2*	60	2*	70	2*	70
Caterpillar	D350C	35	2*	75	CT	CT	2*	75
Caterpillar	725	25	1*	55	2*	60	2*	60
Caterpillar	725	26	2*	60	2*	70	2*	65
Caterpillar	725C	26	2*	70	2*	60	2*	60
Caterpillar	730	30	2*	60	2*	75	2*	75
Caterpillar	730	31	2*	65	CT	CT	CT	CT
Caterpillar	730 EJ	31	2*	60	CT	CT	CT	CT
Caterpillar	730C	31	2*	80	2*	70	2*	70

Pressure and ply recommendations based on normal quarry operations with standard equipment. For different applications, or modified equipment, please contact OTR Field Engineering for a specific recommendation. Tire damage or failure caused by improper load, ply, speed or inflation practices is not covered by the Titan Tire Warranty Policy.

CT - Contact Titan Technical services

Load and Inflation Tables

23.5R25 Articulated Truck Usage Chart continued

For Standard Earthmover Service: < 2.5 mi, < 30 mph

Manufacturer	Model	Payload	Front Minimum Load Rating	Front Minimum Inflation	Middle Minimum Load Rating	Middle Minimum Inflation	Rear Minimum Load Rating	Rear Minimum Inflation
		Tons		Psi		Psi		Psi
Caterpillar	730C EJ	31	2*	70	CT	CT	CT	CT
Deere	250C	25	1*	50	1*	45	1*	50
Deere	250D	25	1*	50	1*	55	1*	55
Deere	250D - II	25	1*	50	1*	55	1*	55
Deere	300C	30	2*	60	2*	65	2*	65
Deere	300D	30	1*	50	2*	65	2*	65
Deere	300D - II	30	1*	55	2*	70	2*	65
Doosan	DA30	31	2*	70	2*	70	2*	70
Doosan	DA30-5	31	2*	70	2*	75	2*	75
Komatsu	HA270-1	27	2*	60	2*	60	2*	60
Komatsu	HM300-1	30	2*	65	2*	80	2*	75
Komatsu	HM300-2	30	2*	65	2*	80	2*	75
Komatsu	HM300-3	31	2*	60	CT	CT	2*	80
Komatsu	HM300-5	31	2*	70	CT	CT	2*	75
Moxy	MT26	26	2*	60	2*	60	2*	60
Moxy	MT30 X	30	2*	75	1*	55	1*	55
Moxy	MT30 LHS	30	2*	60	2*	60	2*	60
Moxy	MT31	31	2*	70	2*	70	2*	70
Randon	RK-628	28	1*	50	2*	60	2*	60
Terex	2566B	25	2*	60	1*	55	1*	50
Terex	2566C	25	2*	60	1*	55	1*	50
Terex	2766B	27.5	2*	65	2*	60	1*	55
Terex	2766C	27.5	2*	65	2*	60	2*	55
Terex	3066	30	2*	65	2*	60	2*	60
Terex	3066C	30	2*	60	2*	70	2*	70
Terex	TA250	27.5	2*	65	2*	65	2*	65
Terex	TA250-9	27.5	2*	70	2*	65	2*	65
Terex	TA300	31	2*	70	2*	70	2*	70
Terex	TA300-T4	31	2*	75	2*	70	2*	70
Terex	TA300-9	31	2*	60	2*	80	2*	80
Volvo	A20 6X4	20	1*	40	CT	-	CT	-
Volvo	A25	25	1*	40	1*	55	1*	55
Volvo	A25 4X4	25	1*	45	1*	40	1*	40
Volvo	A25 6X4	25	1*	40	1*	55	1*	55
Volvo	A25B	25	1*	40	1*	55	1*	55
Volvo	A25B 4X4	25	1*	45	1*	40	1*	40
Volvo	A25C	25	1*	45	2*	55	2*	55
Volvo	A25C 4X4	25	1*	50	1*	40	1*	40
Volvo	A25C 6X6	25	1*	45	2*	55	2*	55
Volvo	A25D	27	1*	55	2*	65	2*	65
Volvo	A25E	27	1*	55	2*	65	2*	65
Volvo	A25E 4X4	26.5	2*	65	CT	-	CT	-
Volvo	A25F	27	2*	60	2*	65	2*	65
Volvo	A25G	26.5	2*	60	2*	65	2*	65
Volvo	A30	30	2*	60	2*	65	2*	65

Pressure and ply recommendations based on normal quarry operations with standard equipment. For different applications, or modified equipment, please contact OTR Field Engineering for a specific recommendation. Tire damage or failure caused by improper load, ply, speed or inflation practices is not covered by the Titan Tire Warranty Policy.

CT - Contact Titan Technical services

26.5R25 Articulated Truck Usage Chart

For Standard Earthmover Service: < 2.5 mi, < 30 mph

Manufacturer	Model	Payload	Front Minimum Load Rating	Front Minimum Inflation	Middle Minimum Load Rating	Middle Minimum Inflation	Rear Minimum Load Rating	Rear Minimum Inflation
		Tons		Psi		Psi		Psi
Bell	B35D	35.8	2*	60	2*	70	2*	70
Bell	B40	40	2*	65	CT	CT	2*	75
Bell	B40B	40	2*	70	2*	75	2*	75
Bell	B40D 6x4	40	2*	60	CT	CT	2*	75
Caterpillar	D25C	25	2*	65	-	-	2*	75
Caterpillar	D25D	25	2*	65	-	-	2*	75
Caterpillar	D350C	35	2*	55	2*	60	2*	55
Caterpillar	D350D	35	2*	60	2*	60	2*	60
Caterpillar	D400D	40	2*	65	2*	75	2*	75
Caterpillar	735	35	2*	70	2*	70	2*	70
Caterpillar	735	36	2*	75	2*	70	2*	65
Caterpillar	735B	36	CT	CT	2*	70	2*	70
Caterpillar	735B	36	CT	CT	2*	70	2*	65
Caterpillar	735C	36	2*	70	2*	70	2*	70
Deere	350C	35	2*	60	2*	65	2*	65
Deere	350D	35	2*	55	2*	65	2*	65
Deere	350D Series II	35	2*	65	2*	65	2*	65
Deere	370E	37	2*	70	2*	75	2*	70
Komatsu	HM350-2	35.6	2*	65	2*	70	2*	70
Moxy	MT36	36	2*	65	2*	65	2*	65
Moxy	MT40	40	2*	60	2*	70	2*	70
Terex	4066	37	1*	50	2*	70	2*	70
Terex	4066B	40	2*	60	2*	75	2*	75
Terex	4066C	40	2*	60	CT	CT	CT	CT
Terex	TA350	37.59	1*	55	CT	CT	CT	CT
Volvo	A35	35	1*	50	2*	65	2*	65
Volvo	A35C	35	1*	50	2*	65	2*	65
Volvo	A35C 6X6	35	1*	50	2*	65	2*	65
Volvo	A35D	36	1*	55	2*	70	2*	70
Volvo	A35E	37	1*	55	2*	75	2*	75
Volvo	A35E-FS	37	1*	55	2*	75	2*	75
Volvo	A35F	37	2*	60	2*	75	2*	75
Volvo	A35F-FS	37	2*	60	2*	75	2*	75
Volvo	A35G	37	2*	60	2*	75	2*	75
Volvo	A35G-FS	37	2*	60	2*	75	2*	75

Pressure and ply recommendations based on normal quarry operations with standard equipment. For different applications, or modified equipment, please contact OTR Field Engineering for a specific recommendation. Tire damage or failure caused by improper load, ply, speed or inflation practices is not covered by the Titan Tire Warranty Policy.

CT - Contact Titan Technical services

Load and Inflation Tables

29.5R25 Articulated Truck Usage Chart

For Standard Earthmover Service: < 2.5 mi, < 30 mph

Manufacturer	Model	Payload	Front Minimum Load Rating	Front Minimum Inflation	Middle Minimum Load Rating	Middle Minimum Inflation	Rear Minimum Load Rating	Rear Minimum Inflation
		Tons		Psi		Psi		Psi
Atlas	FB-645	45	2*	65	2*	70	2*	70
Bell	B40B	40	1*	55	2*	60	2*	55
Bell	B40D	41	1*	50	2*	65	2*	60
Bell	B45D	45	1*	55	2*	70	2*	70
Caterpillar	D30C 4x4	30	1*	55	-	-	2*	75
Caterpillar	D30D 4x4	30	1*	55	-	-	2*	75
Caterpillar	D35C	35	1*	55	-	-	-	-
Caterpillar	D40D	40	2*	70	-	-	-	-
Caterpillar	D350C	35	1*	45	1*	45	1*	45
Caterpillar	D350D	35	1*	50	1*	45	1*	45
Caterpillar	D400D	40	1*	55	2*	55	2*	55
Caterpillar	D400E	40	2*	60	1*	55	1*	55
Caterpillar	740	40	2*	65	2*	60	2*	60
Caterpillar	740	43.5	2*	65	2*	65	2*	65
Caterpillar	740 EJ	42	1*	55	2*	70	2*	70
Caterpillar	740B	43.5	2*	70	2*	65	2*	65
Caterpillar	740B EJ	42	2*	60	2*	70	2*	70
Caterpillar	740C EJ	42	2*	60	2*	70	2*	70
Caterpillar	745C	45	2*	70	2*	65	2*	65
Deere	370E	37	1*	55	2*	55	1*	55
Deere	400C	40	1*	55	2*	60	2*	55
Deere	400D	40	1*	50	2*	60	2*	60
Deere	400D Series II	40	1*	50	2*	65	2*	60
Deere	410E	41	1*	55	2*	65	2*	65
Deere	460E	46	2*	60	2*	70	2*	70
Doosan	DA40	44	1*	55	2*	65	2*	65
Doosan	DA40-5	44	2*	55	2*	65	2*	65
Komatsu	HD400	40	1*	45	2*	65	2*	65
Komatsu	HM400-2	40	1*	50	2*	65	2*	65
Komatsu	HM400-3	44	1*	55	2*	70	2*	70
Komatsu	HM400-5	44	2*	60	2*	75	2*	70
Moxy	MT41	41	1*	50	2*	60	2*	60
Moxy	MT51	51	2*	60	2*	75	2*	75
Terex	TA400-9	42	1*	45	2*	70	2*	70
Volvo	A40	40	1*	45	2*	65	2*	65
Volvo	A40D	41	1*	50	2*	65	2*	65
Volvo	A40E	43	1*	50	2*	65	2*	65
Volvo	A40E-FS	43	1*	50	2*	65	2*	65
Volvo	A40F	43	1*	50	2*	65	2*	65
Volvo	A40F-FS	43	1*	50	2*	65	2*	65
Volvo	A40G	43	1*	50	2*	65	2*	65
Volvo	A40G-FS	43	1*	55	2*	65	2*	65
Volvo	A25 4X4	25	-	-	-	-	2*	70
Volvo	A25B 4X4	25	-	-	-	-	2*	70
Volvo	A25C 4X4	25	-	-	-	-	2*	70
Volvo	A25E 4X4	26.5	-	-	-	-	2*	75

Pressure and ply recommendations based on normal quarry operations with standard equipment. For different applications, or modified equipment, please contact OTR Field Engineering for a specific recommendation. Tire damage or failure caused by improper load, ply, speed or inflation practices is not covered by the Titan Tire Warranty Policy.

CT - Contact Titan Technical services

750/65R25 Articulated Truck Usage Chart

For Standard Earthmover Service: < 2.5 mi, < 30 mph

Manufacturer	Model	Payload	Front Minimum Load Rating	Front Minimum Inflation	Middle Minimum Load Rating	Middle Minimum Inflation	Rear Minimum Load Rating	Rear Minimum Inflation
		Tons		Psi		Psi		Psi
Bell	B30D	30	1*	40	1*	45	1*	45
Bell	B30E	31	1*	40	1*	50	1*	50
Caterpillar	725C	26	1*	50	1*	40	1*	40
Caterpillar	730C	31	1*	55	1*	50	1*	50
Caterpillar	730C EJ	31	1*	45	1*	55	1*	55
Deere	300D - II	30	1*	40	1*	45	1*	45
Komatsu	HM300-5	31	1*	45	1*	55	1*	50
Terex	TA250-9	26.5	1*	50	1*	45	1*	45
Terex	TA300-9	31	1*	40	1*	55	1*	55
Volvo	A25G	27	1*	40	1*	45	1*	45
Volvo	A30D	31	1*	40	1*	50	1*	50
Volvo	A30E	31	1*	40	1*	50	1*	50
Volvo	A30G	31	1*	45	1*	50	1*	50

875/65R29 Articulated Truck Usage Chart

For Standard Earthmover Service: < 2.5 mi, < 30 mph

Manufacturer	Model	Payload	Front Minimum Load Rating	Front Minimum Inflation	Middle Minimum Load Rating	Middle Minimum Inflation	Rear Minimum Load Rating	Rear Minimum Inflation
		Tons		Psi		Psi		Psi
Bell	50D	50	2*	55	2*	70	2*	70
Caterpillar	740C EJ	42	2*	50	2*	65	2*	60
Caterpillar	745C	45	2*	60	2*	60	2*	55
Deere	370E	37	2*	50	2*	50	2*	50
Deere	410E	42.5	2*	50	2*	60	2*	60
Deere	460E	46	2*	55	2*	65	2*	65
Volvo	A40D	41	2*	45	2*	60	2*	60
Volvo	A40F	43	2*	45	2*	60	2*	60
Volvo	A40F-FS	43	2*	45	2*	60	2*	60
Volvo	A40G	43	2*	45	2*	60	2*	60
Volvo	A40G-FS	43	2*	50	2*	60	2*	60

Pressure and ply recommendations based on normal quarry operations with standard equipment. For different applications, or modified equipment, please contact OTR Field Engineering for a specific recommendation. Tire damage or failure caused by improper load, ply, speed or inflation practices is not covered by the Titan Tire Warranty Policy.

CT - Contact Titan Technical services

Load and Inflation Tables

14.00R24TG Grader Usage Chart

For Standard Grader Service: Unlimited distance, < 25 mph

Manufacturer	Model	Front Minimum Load Rating	Front Minimum Inflation	Middle Minimum Load Rating	Middle Minimum Inflation	Rear Minimum Load Rating	Rear Minimum Inflation
			Psi		Psi		Psi
Case	845B	1*	30	1*	40	1*	40
Case	865B	1*	30	1*	40	1*	40
Case	865B AWD	1*	35	1*	40	1*	40
Case	885B	1*	40	1*	45	1*	45
Case	885B AWD	1*	45	1*	45	1*	45
Caterpillar	12M2	1*	40	1*	50	1*	50
Caterpillar	12M2 AWD	1*	45	1*	55	1*	55
Caterpillar	12M3	1*	40	1*	55	1*	55
Caterpillar	12M3 AWD	1*	45	1*	55	1*	55
Caterpillar	120M2	1*	35	1*	50	1*	50
Caterpillar	120M2 AWD	1*	35	1*	50	1*	50
Caterpillar	140H	1*	30	1*	40	1*	40
Caterpillar	140M	1*	40	1*	50	1*	50
Caterpillar	140M AWD	1*	40	1*	55	1*	55
Caterpillar	140M2	1*	40	1*	55	1*	55
Caterpillar	140M2 AWD	1*	45	1*	55	1*	55
Caterpillar	140M3	1*	40	1*	55	1*	55
Caterpillar	140M3 AWD	1*	45	CT	CT	CT	CT
Caterpillar	160M	1*	40	1*	55	1*	55
Caterpillar	160M AWD	1*	45	1*	55	1*	55
Caterpillar	160M2	1*	45	1*	55	1*	55
Caterpillar	160M2 AWD	1*	50	CT	CT	CT	CT
Caterpillar	160M3	1*	45	CT	CT	CT	CT
Caterpillar	160M3 AWD	1*	50	CT	CT	CT	CT
Deere	670G Std	1*	30	1*	45	1*	45
Deere	670G w/ ripper	1*	40	1*	50	1*	50
Deere	672G Std	1*	35	1*	45	1*	45
Deere	672G w/ ripper	1*	45	1*	55	1*	55
Deere	770G std	1*	30	1*	45	1*	45
Deere	770G w/ ripper	1*	40	1*	55	1*	55
Deere	772G std	1*	35	1*	45	1*	45
Deere	772G w/ ripper	1*	45	1*	55	1*	55
Deere	870G std	1*	30	1*	45	1*	45
Deere	870G w/ ripper	1*	40	1*	55	1*	55
Deere	872G std	1*	35	1*	50	1*	50
Deere	872G w/ ripper	1*	45	CT	CT	CT	CT
Terex	TG140	1*	40	1*	40	1*	40
Terex	TG180	1*	45	1*	45	1*	45
Terex	TG200	1*	50	1*	45	1*	45
Volvo	G930B	1*	30	1*	40	1*	40
Volvo	G930C	1*	30	1*	45	1*	45
Volvo	G940B	1*	35	1*	45	1*	45
Volvo	G940C	1*	35	1*	45	1*	45
Volvo	G946B	1*	35	1*	45	1*	45
Volvo	G946C	1*	35	1*	50	1*	50
Volvo	G960B	1*	35	1*	50	1*	50
Volvo	G960C	1*	35	1*	50	1*	50

Pressure and ply recommendations based on normal quarry operations with standard equipment. For different applications, or modified equipment, please contact OTR Field Engineering for a specific recommendation. Tire damage or failure caused by improper load, ply, speed or inflation practices is not covered by the Titan Tire Warranty Policy.

CT - Contact Titan Technical services

17.5R25 Grader Usage Chart

For Standard Grader Service: Unlimited distance, < 25 mph

Manufacturer	Model	Front Minimum Load Rating	Front Minimum Inflation	Middle Minimum Load Rating	Middle Minimum Inflation	Rear Minimum Load Rating	Rear Minimum Inflation
			Psi		Psi		Psi
Case	845B	1*	30	1*	40	1*	40
Case	865B	1*	30	1*	40	1*	40
Case	865B AWD	1*	30	1*	40	1*	40
Case	885B	1*	35	1*	40	1*	40
Case	885B AWD	1*	35	1*	40	1*	40
Caterpillar	12M2	1*	30	1*	45	1*	45
Caterpillar	12M2 AWD	1*	35	1*	45	1*	45
Caterpillar	12M3	1*	30	1*	45	1*	45
Caterpillar	12M3 AWD	1*	35	1*	45	1*	45
Caterpillar	120M2	1*	30	1*	40	1*	40
Caterpillar	120M2 AWD	1*	30	1*	45	1*	45
Caterpillar	140H	1*	30	1*	40	1*	40
Caterpillar	140M	1*	30	1*	45	1*	45
Caterpillar	140M AWD	1*	35	1*	45	1*	45
Caterpillar	140M2	1*	35	1*	45	1*	45
Caterpillar	140M2 AWD	1*	35	1*	45	1*	45
Caterpillar	140M3	1*	35	1*	45	1*	45
Caterpillar	140M3 AWD	1*	40	CT	CT	CT	CT
Caterpillar	160M	1*	35	1*	45	1*	45
Caterpillar	160M AWD	1*	35	1*	45	1*	45
Caterpillar	160M2	1*	35	1*	45	1*	45
Caterpillar	160M2 AWD	1*	40	CT	CT	CT	CT
Caterpillar	160M3	1*	35	CT	CT	CT	CT
Caterpillar	160M3 AWD	1*	40	CT	CT	CT	CT
Deere	670G Std	1*	30	1*	40	1*	40
Deere	670G w/ ripper	1*	35	1*	45	1*	45
Deere	672G Std	1*	30	1*	40	1*	40
Deere	672G w/ ripper	1*	35	1*	45	1*	45
Deere	770G std	1*	30	1*	40	1*	40
Deere	770G w/ ripper	1*	35	1*	45	1*	45
Deere	772G std	1*	30	1*	40	1*	40
Deere	772G w/ ripper	1*	35	1*	45	1*	45
Deere	870G std	1*	30	1*	40	1*	40
Deere	870G w/ ripper	1*	35	1*	45	1*	45
Deere	872G std	1*	30	1*	40	1*	40
Deere	872G w/ ripper	1*	40	CT	CT	CT	CT
Komatsu	GD655-5	1*	30	1*	40	1*	40
Komatsu	GD655-5 w/ ripper	1*	30	1*	40	1*	40
Komatsu	GD655-5 w/ scarifier	1*	30	1*	40	1*	40
Volvo	G930B	1*	30	1*	40	1*	40
Volvo	G930C	1*	30	1*	45	1*	45
Volvo	G940B	1*	30	1*	40	1*	40
Volvo	G940C	1*	30	CT	CT	CT	CT
Volvo	G946B	1*	30	1*	40	1*	40
Volvo	G946C	1*	30	CT	CT	CT	CT
Volvo	G960B	1*	30	1*	40	1*	40
Volvo	G960C	1*	35	CT	CT	CT	CT

Pressure and ply recommendations based on normal quarry operations with standard equipment. For different applications, or modified equipment, please contact OTR Field Engineering for a specific recommendation. Tire damage or failure caused by improper load, ply, speed or inflation practices is not covered by the Titan Tire Warranty Policy.

CT - Contact Titan Technical services

Load and Inflation Tables

20.5R25 Grader Usage Chart

For Standard Grader Service: Unlimited distance, < 25 mph

Manufacturer	Model	Front Minimum Load Rating	Front Minimum Inflation	Middle Minimum Load Rating	Middle Minimum Inflation	Rear Minimum Load Rating	Rear Minimum Inflation
			Psi		Psi		Psi
Caterpillar	14M	1*	30	1*	45	1*	45

29.5R29 Grader Usage Chart

For Standard Grader Service: Unlimited distance, < 25 mph

Manufacturer	Model	Front Minimum Load Rating	Front Minimum Inflation	Middle Minimum Load Rating	Middle Minimum Inflation	Rear Minimum Load Rating	Rear Minimum Inflation
			Psi		Psi		Psi
Caterpillar	24M	1*	45	1*	60	1*	60

Pressure and ply recommendations based on normal quarry operations with standard equipment. For different applications, or modified equipment, please contact OTR Field Engineering for a specific recommendation. Tire damage or failure caused by improper load, ply, speed or inflation practices is not covered by the Titan Tire Warranty Policy.

CT - Contact Titan Technical services

17.5R25 Loader Usage Chart

For Standard Loader Service: <250 ft, < 5 mph

Manufacturer	Model	Bucket	Front Minimum Load Rating	Front Minimum Inflation	Rear Minimum Load Rating	Rear Minimum Inflation
		Cu.Yd.		Psi		Psi
Caterpillar	IT14B	1.6	1*	60	1*	60
Caterpillar	IT14F	1.6	1*	60	1*	60
Caterpillar	IT14G	1.7	1*	60	1*	60
Caterpillar	IT18	1.5	1*	60	1*	60
Caterpillar	IT18B	1.75	1*	60	1*	60
Caterpillar	IT18F	2	1*	65	1*	60
Caterpillar	IT24	2.3	1*	65	1*	60
Caterpillar	IT24F	2.4	1*	75	1*	60
Caterpillar	IT28	2	1*	65	1*	60
Caterpillar	IT28B	2.25	1*	70	1*	60
Caterpillar	IT28F	2.6	1*	75	1*	60
Caterpillar	914G	1.7	1*	60	1*	60
Caterpillar	914G2	1.8	1*	60	1*	60
Caterpillar	914K	1.7	1*	60	1*	60
Caterpillar	914K HL	1.7	1*	60	1*	60
Caterpillar	916	2	1*	60	1*	60
Caterpillar	918F	2	1*	60	1*	60
Caterpillar	924F	2.25	1*	65	1*	60
Caterpillar	924Gz	2.3	1*	65	1*	60
Caterpillar	924K	2.5	1*	85	1*	60
Caterpillar	926	1.75	1*	60	1*	60
Caterpillar	926E	2.25	1*	65	1*	60
Caterpillar	926M	2.5	1*	85	1*	60
Caterpillar	928F	2.6	1*	75	1*	60
Caterpillar	928G	2.6	1*	75	1*	60
Caterpillar	930	2.25	1*	65	1*	60
Caterpillar	936	2.75	1*	85	1*	60
Caterpillar	936E	3	1*	90	1*	60
Caterpillar	936F	3	1*	90	1*	60
Case	W14C	1.7	1*	60	1*	60
Case	W18	2	1*	60	1*	60
Case	W18B	2	1*	60	1*	60
Case	W20	2	1*	65	1*	60
Case	W20B	2.5	1*	70	1*	60
Case	W20C	2	1*	60	1*	60
Case	W24B	2.5	1*	70	1*	60
Case	W24C	3	1*	80	1*	60
Case	521D	2	1*	60	1*	60
Case	621	2.2	1*	70	1*	60
Daewoo	Mega 200	2.4	1*	70	1*	60
Daewoo	Mega 200-III	2.3	1*	70	1*	60
Deere	304H	1.25	1*	60	1*	60
Deere	304H WH	1	1*	60	1*	60
Deere	324H	1.75	1*	60	1*	60

For service under chains, or load and carry operations, contact Titan Technical Services.

Pressure and ply recommendations based on normal quarry operations with standard equipment. For different applications, or modified equipment, please contact OTR Field Engineering for a specific recommendation. Tire damage or failure caused by improper load, ply, speed or inflation practices is not covered by the Titan Tire Warranty Policy.

CT - Contact Titan Technical services

HL - High Lift, extended booms, etc.

Load and Inflation Tables

17.5R25 Loader Usage Chart continued

For Standard Loader Service: <250 ft, < 5 mph

Manufacturer	Model	Bucket	Front Minimum Load Rating	Front Minimum Inflation	Rear Minimum Load Rating	Rear Minimum Inflation
		Cu.Yd.		Psi		Psi
Deere	344E	1.6	1*	60	1*	60
Deere	344G	1.6	1*	60	1*	60
Deere	344H	2	1*	60	1*	60
Deere	344K	1.75	1*	60	1*	60
Deere	444	1.5	1*	60	1*	60
Deere	444C	1.75	1*	60	1*	60
Deere	444D	1.75	1*	60	1*	60
Deere	444E	1.75	1*	60	1*	60
Deere	444G	1.75	1*	60	1*	60
Deere	444H	2.5	1*	70	1*	60
Deere	444H HL	2.5	1*	75	1*	60
Deere	444K Z-bar	2.5	1*	75	1*	60
Deere	444K HL	2.5	1*	80	1*	60
Deere	444K Powerllel	2.5	1*	85	1*	60
Deere	544B	1.75	1*	60	1*	60
Deere	544C	2	1*	65	1*	60
Deere	544D	2.2	1*	65	1*	60
Deere	544E	2.2	1*	65	1*	60
Deere	544G	2.5	1*	70	1*	60
Deere	544G-TC	2.5	1*	75	1*	60
Deere	TC44H	2	1*	60	1*	60
Deere	TC54H	2.5	1*	65	1*	60
Deere	TC62H	3	1*	70	1*	60
Fiatallis	FR7B	1.4	1*	60	1*	60
Fiatallis	FR7C	1.4	1*	60	1*	60
Fiatallis	FR70	1.4	1*	60	1*	60
Fiatallis	345B	1.5	1*	60	1*	60
Fiatallis	FR9B PL	1.7	1*	60	1*	60
Fiatallis	FR90 PL	1.8	1*	60	1*	60
Fiatallis	FR9B	1.8	1*	60	1*	60
Fiatallis	FR9C	1.8	1*	60	1*	60
Fiatallis	FR90	1.8	1*	60	1*	60
Fiatallis	FR10	2	1*	60	1*	60
Fiatallis	FR10B	2.2	1*	65	1*	60
Fiatallis	FR10C	2.25	1*	65	1*	60
Fiatallis	FR100	2.25	1*	65	1*	60
Fiatallis	FR11	2.5	1*	75	1*	60
Fiatallis	FR12	2.5	1*	75	1*	60
Fiatallis	FR12B	2.5	1*	70	1*	60
Fiatallis	FR120	2.5	1*	70	1*	60
Fiatallis	FR120-2	2.5	1*	75	1*	60
Fiatallis	FW130	2.75	1*	80	1*	60
Fiatallis	FW110	2.2	1*	65	1*	60
Fiat Hitachi	W110	2.1	1*	60	1*	60
Fiat Hitachi	W130 PL	2.6	1*	75	1*	60

For service under chains, or load and carry operations, contact Titan Technical Services.

Pressure and ply recommendations based on normal quarry operations with standard equipment. For different applications, or modified equipment, please contact OTR Field Engineering for a specific recommendation. Tire damage or failure caused by improper load, ply, speed or inflation practices is not covered by the Titan Tire Warranty Policy.

CT - Contact Titan Technical services

HL - High Lift, extended booms, etc.

17.5R25 Loader Usage Chart continued

For Standard Loader Service: <250 ft, < 5 mph

Manufacturer	Model	Bucket	Front	Front	Rear	Rear
			Minimum Load Rating	Minimum Inflation	Minimum Load Rating	Minimum Inflation
		Cu.Yd.		Psi		Psi
Furukawa	FL120-I	1.7	1*	60	1*	60
Furukawa	FL120A-I	1.7	1*	60	1*	60
Hitachi	ZW120	2	1*	60	1*	60
Hitachi	ZW120 HL	1.75	1*	60	1*	60
Hitachi	ZW140	2.6	1*	70	1*	60
Hitachi	ZW140 HL	2	1*	65	1*	60
Hyundai	HL17	2.4	1*	75	1*	60
Hyundai	HL730-9A	2.5	1*	70	1*	60
Hyundai	HL730XTD-9A	2.5	1*	75	1*	60
Hyundai	HL730TM-9A	2.2	1*	70	1*	60
Hyundai	HL740-9A	3	1*	90	1*	60
Hyundai	HL740XTD-9A	3	2*	CT	1*	60
Hyundai	HL740TM-9A	3	2*	CT	1*	65
Hyundai	HL757-9A	3.7	2*	CT	1*	65
Hyundai	HL757XTD-9A	3.7	CT	CT	1*	75
Hyundai	HL757TM-9A	3.5	CT	CT	1*	70
Hyundai	HL940	3	1*	90	1*	60
Hyundai	HL940 XT	3	2*	CT	1*	60
Hyundai	HL955	3.1	2*	CT	1*	60
Hyundai	HL955 XTD	3.1	2*	CT	1*	65
JCB	416HT	2.2	1*	65	1*	60
Kawasaki	50ZIV	1.7	1*	60	1*	60
Kawasaki	50ZIV-2	2	1*	60	1*	60
Kawasaki	60Z	2.1	1*	60	1*	60
Kawasaki	60ZII	2.1	1*	60	1*	60
Kawasaki	60ZIII	2.1	1*	60	1*	60
Kawasaki	60ZIV	2.1	1*	60	1*	60
Kawasaki	60ZIV-2	2.5	1*	65	1*	60
Kawasaki	60Z7	2	1*	60	1*	60
Kawasaki	60ZV-2	2.2	1*	60	1*	60
Kawasaki	60ZV-2 HL	2.2	1*	65	1*	60
Kawasaki	60ZV-2 SHL	2.2	1*	70	1*	60
Kawasaki	62Z7	2.75	1*	75	1*	60
Kawasaki	65TM-2	2.6	2*	CT	1*	60
Kawasaki	65Z	2.3	1*	65	1*	60
Kawasaki	65ZII	2.3	1*	65	1*	60
Kawasaki	65ZIII	2.6	1*	70	1*	60
Kawasaki	65ZIV	2.6	1*	75	1*	60
Kawasaki	65ZIV-2	3	1*	80	1*	60
Kawasaki	65ZV-2	3	1*	80	1*	60
Kawasaki	65ZV-2 HL	2.8	1*	80	1*	60
Kawasaki	65ZV-2 SHL	2.8	1*	85	1*	60
Komatsu	WA120-1	1.75	1*	60	1*	60
Komatsu	WA120-3	1.85	1*	60	1*	60

For service under chains, or load and carry operations, contact Titan Technical Services.

Pressure and ply recommendations based on normal quarry operations with standard equipment. For different applications, or modified equipment, please contact OTR Field Engineering for a specific recommendation. Tire damage or failure caused by improper load, ply, speed or inflation practices is not covered by the Titan Tire Warranty Policy.

CT - Contact Titan Technical services

HL - High Lift, extended booms, etc.

Load and Inflation Tables

17.5R25 Loader Usage Chart continued

For Standard Loader Service: <250 ft, < 5 mph

Manufacturer	Model	Bucket	Front Minimum Load Rating	Front Minimum Inflation	Rear Minimum Load Rating	Rear Minimum Inflation
		Cu.Yd.		Psi		Psi
Komatsu	WA150-5	2	1*	60	1*	60
Komatsu	WA180-1	2.25	1*	65	1*	60
Komatsu	WA180-3	2.9	1*	75	1*	60
Komatsu	WA180-3 PTC	2.5	1*	70	1*	60
Komatsu	WA200-5	2.6	1*	70	1*	60
Komatsu	WA200-6	2.6	1*	70	1*	60
Komatsu	WA200PZ-6	2.6	1*	75	1*	60
Komatsu	WA200-7	2.6	1*	75	1*	60
Komatsu	WA250-5	3	1*	80	1*	60
Komatsu	WA250-6	3	1*	75	1*	60
Komatsu	WA250PZ-6	2.9	1*	85	1*	60
Komatsu Dresser	512	1.7	1*	60	1*	60
Komatsu Dresser	515B	1.6	1*	60	1*	60
Komatsu Dresser	515C	2	1*	60	1*	60
Komatsu Dresser	515CH	2	1*	60	1*	60
Komatsu Dresser	518	2.2	1*	65	1*	60
Komatsu Dresser	520B	2.25	1*	65	1*	60
Komatsu Dresser	520C	2.5	1*	70	1*	60
Liebherr	L524 Z-bar	2.7	1*	75	1*	60
Liebherr	L524	2.4	1*	75	1*	60
Liebherr	L524 HL	2.4	1*	80	1*	60
Liebherr	L528 Z-bar	3	1*	80	1*	60
Liebherr	L528	2.7	1*	80	1*	60
Liebherr	L528 HL	2.7	1*	90	1*	60
Terex	33C	1.75	1*	60	1*	60
Terex	44C	2.25	1*	75	1*	60
Volvo	L45H	2	1*	60	1*	60
Volvo	L50C	2	1*	60	1*	60
Volvo	L50D	2	1*	60	1*	60
Volvo	L50H	2.1	1*	65	1*	60
Volvo	L60G	2.75	1*	80	1*	60
Volvo	L60H	2.75	1*	80	1*	60
Volvo	L70B	2.1	1*	65	1*	60
Volvo	L70C	2.5	1*	70	1*	60
Volvo	L70D	2.5	1*	75	1*	60

For service under chains, or load and carry operations, contact Titan Technical Services.

Pressure and ply recommendations based on normal quarry operations with standard equipment. For different applications, or modified equipment, please contact OTR Field Engineering for a specific recommendation. Tire damage or failure caused by improper load, ply, speed or inflation practices is not covered by the Titan Tire Warranty Policy.

CT - Contact Titan Technical services

HL - High Lift, extended booms, etc.

20.5R25 Loader Usage Chart

For Standard Loader Service: <250 ft, < 5 mph

Manufacturer	Model	Bucket	Front Minimum Load Rating	Front Minimum Inflation	Rear Minimum Load Rating	Rear Minimum Inflation
		Cu.Yd.		Psi		Psi
Caterpillar	IT38F	3.25	1*	70	1*	60
Caterpillar	IT38G	3.3	1*	70	1*	60
Caterpillar	IT38H	3.3	1*	80	1*	60
Caterpillar	924G	2.3	1*	60	1*	60
Caterpillar	924H	2.4	1*	60	1*	60
Caterpillar	924Hz	2.3	1*	60	1*	60
Caterpillar	924K	2.5	1*	65	1*	60
Caterpillar	926M	2.5	1*	65	1*	60
Caterpillar	928Hz	2.6	1*	60	1*	60
Caterpillar	930H	2.7	1*	60	1*	60
Caterpillar	930K	2.75	1*	65	1*	60
Caterpillar	930M	2.75	1*	70	1*	60
Caterpillar	936F TC	3	1*	65	1*	60
Caterpillar	938F	3.25	1*	70	1*	60
Caterpillar	938G	3.25	1*	70	1*	60
Caterpillar	938H	3.65	1*	80	1*	60
Caterpillar	938K	3.25	1*	75	1*	60
Caterpillar	938M	3.25	1*	80	1*	60
Caterpillar	950B	3.75	1*	85	1*	60
Caterpillar	950F	4	1*	90	1*	60
Case	621B	2.25	1*	60	1*	60
Case	621B	3	1*	65	1*	60
Case	621B XT	2.25	1*	60	1*	60
Case	621D	2.5	1*	60	1*	60
Case	621E	3	1*	65	1*	60
Case	621E XT	3	1*	65	1*	60
Case	621E XR	3	1*	65	1*	60
Case	721	2.75	1*	60	1*	60
Case	721B	2.75	1*	60	1*	60
Case	721B XT	2.75	1*	65	1*	60
Case	721C	2.75	1*	65	1*	60
Case	721E	3.5	1*	70	1*	60
Case	721E XT	3	1*	65	1*	60
Case	721E XR	3	1*	70	1*	60
Case	721F	3	1*	65	1*	60
Case	721F XT	3	1*	70	1*	60
Case	721F XR	3	1*	70	1*	60
Case	W30	3.5	1*	65	1*	60
Daewoo	Mega 250-III	3.1	1*	70	1*	60
Deere	444K Z-bar	2.5	1*	60	1*	60
Deere	444K HL	2.5	1*	60	1*	60
Deere	444K Powerlifel	2.5	1*	60	1*	60
Deere	524K	2.75	1*	60	1*	60
Deere	524K-HL	2.75	1*	60	1*	60

For service under chains, or load and carry operations, contact Titan Technical Services.

Pressure and ply recommendations based on normal quarry operations with standard equipment. For different applications, or modified equipment, please contact OTR Field Engineering for a specific recommendation. Tire damage or failure caused by improper load, ply, speed or inflation practices is not covered by the Titan Tire Warranty Policy.

CT - Contact Titan Technical services

HL - High Lift, extended booms, etc.

Load and Inflation Tables

20.5R25 Loader Usage Chart continued

For Standard Loader Service: <250 ft, < 5 mph

Manufacturer	Model	Bucket	Front Minimum Load Rating	Front Minimum Inflation	Rear Minimum Load Rating	Rear Minimum Inflation
		Cu.Yd.		Psi		Psi
Deere	544H	3	1*	65	1*	60
Deere	544H-HL	3	1*	65	1*	60
Deere	544K	3	1*	65	1*	60
Deere	544K-HL	3	1*	65	1*	60
Deere	624E	2.6	1*	60	1*	60
Deere	624G	3.25	1*	70	1*	60
Deere	624H	3.5	1*	70	1*	60
Deere	624H-HL	3	1*	70	1*	60
Deere	624K	3.5	1*	75	1*	60
Deere	624K-HL	3.5	1*	75	1*	60
Deere	644B	2.5	1*	60	1*	60
Deere	644C	3	1*	65	1*	60
Doosan	DL200	2.6	1*	60	1*	60
Doosan	DL200TC	2.6	1*	60	1*	60
Doosan	DL250	3.3	1*	70	1*	60
Doosan	DL250TC	3.4	1*	75	1*	60
Doosan	DL250HL	3.4	1*	75	1*	60
Dressta	520E	2.3	1*	60	1*	60
Fiatalis	FR130	3	1*	65	1*	60
Fiatalis	FR130-2	3	1*	65	1*	60
Fiatalis	FR140	3	1*	65	1*	60
Fiatalis	FR140-2	3.25	1*	70	1*	60
Fiatalis	FR15	3	1*	70	1*	60
Fiatalis	FR15B	3.1	1*	70	1*	60
Fiat Hitachi	W170 PL	3.9	1*	80	1*	60
Furukawa	FL150-I	2	1*	60	1*	60
Furukawa	FL200-I	2.6	1*	60	1*	60
Furukawa	FL230-I	3.1	1*	70	1*	60
Hitachi	ZW150	3	1*	60	1*	60
Hitachi	ZW150 HL	2.6	1*	60	1*	60
Hitachi	ZW180	3.6	1*	75	1*	60
Hitachi	ZW180 HL	3.1	1*	75	1*	60
Hyundai	HL25	3.5	1*	80	1*	60
Hyundai	HL740-7A	2.7	1*	60	1*	60
Hyundai	HL740TM-7A	2.6	1*	60	1*	60
Hyundai	HL740XTD-7A	2.7	1*	60	1*	60
Hyundai	HL740-9A	3	1*	70	1*	60
Hyundai	HL740XTD-9A	3	1*	70	1*	60
Hyundai	HL740TM-9A	3	1*	75	1*	60
Hyundai	HL750	3	1*	65	1*	60
Hyundai	HL757-7A	3.5	1*	75	1*	60
Hyundai	HL757TM-7A	3.3	1*	80	1*	60
Hyundai	HL757XTD-7A	3.5	1*	80	1*	60
Hyundai	HL757-9A	3.7	1*	80	1*	60
Hyundai	HL757XTD-9A	3.7	1*	85	1*	60

For service under chains, or load and carry operations, contact Titan Technical Services.

Pressure and ply recommendations based on normal quarry operations with standard equipment. For different applications, or modified equipment, please contact OTR Field Engineering for a specific recommendation. Tire damage or failure caused by improper load, ply, speed or inflation practices is not covered by the Titan Tire Warranty Policy.

CT - Contact Titan Technical services

HL - High Lift, extended booms, etc.

20.5R25 Loader Usage Chart continued

For Standard Loader Service: <250 ft, < 5 mph

Manufacturer	Model	Bucket Cu.Yd.	Front Minimum Load Rating	Front Minimum Inflation	Rear Minimum Load Rating	Rear Minimum Inflation
				Psi		Psi
Hyundai	HL757TM-9A	3.5	1*	85	1*	60
Hyundai	HL760-9A	4.3	2*	CT	1*	60
Hyundai	HL760XTD-9A	4.3	2*	CT	1*	60
Hyundai	HL940	3	1*	65	1*	60
Hyundai	HL940 XT	3	1*	70	1*	60
Hyundai	HL955	3.1	1*	70	1*	60
Hyundai	HL955 XTD	3.1	1*	75	1*	60
Hyundai	HL960	3.8	1*	90	1*	60
Hyundai	HL960 XT	3.8	1*	90	1*	60
JCB	426HT	2.5	1*	60	1*	60
JCB	426HT	2.75	1*	65	1*	60
JCB	426ZX	2.5	1*	60	1*	60
JCB	426ZX	2.75	1*	60	1*	60
JCB	436HT	3.5	1*	75	1*	60
JCB	436ZX	3.5	1*	75	1*	60
JCB	456HT	4.6	2*	CT	1*	70
Kawasaki	62Z7	2.75	1*	60	1*	60
Kawasaki	62Z7 HL	2.75	1*	60	1*	60
Kawasaki	65ZV-2	3	1*	60	1*	60
Kawasaki	65TMV-2	2.5	1*	60	1*	60
Kawasaki	67Z7	3.1	1*	65	1*	60
Kawasaki	67Z7 HL	3.1	1*	65	1*	60
Kawasaki	70Z	3	1*	65	1*	60
Kawasaki	70ZII	3	1*	65	1*	60
Kawasaki	70ZIII	3.25	1*	65	1*	60
Kawasaki	70ZIV	3.25	1*	70	1*	60
Kawasaki	70ZIV-2	3.5	1*	70	1*	60
Kawasaki	70ZV-2	3.5	1*	70	1*	60
Kawasaki	70TMV-2	3.4	1*	80	1*	60
Kawasaki	70Z7	3.7	1*	75	1*	60
Kawasaki	70Z7 HL	3.7	1*	80	1*	60
Kawasaki	80ZV-2	4.2	1*	90	1*	60
Komatsu	WA200-5	2.6	1*	60	1*	60
Komatsu	WA200-6	2.6	1*	60	1*	60
Komatsu	WA200PZ-6	2.5	1*	60	1*	60
Komatsu	WA200-7	2.6	1*	60	1*	60
Komatsu	WA250-1	3	1*	60	1*	60
Komatsu	WA250-3	3.5	1*	65	1*	60
Komatsu	WA250-3 PTC	3	1*	65	1*	60
Komatsu	WA250-5	3	1*	60	1*	60
Komatsu	WA250-6	3	1*	60	1*	60
Komatsu	WA250PZ-6	3	1*	65	1*	60
Komatsu	WA270-7	3	1*	65	1*	60
Komatsu	WA320-1	3.25	1*	70	1*	60

For service under chains, or load and carry operations, contact Titan Technical Services.

Pressure and ply recommendations based on normal quarry operations with standard equipment. For different applications, or modified equipment, please contact OTR Field Engineering for a specific recommendation. Tire damage or failure caused by improper load, ply, speed or inflation practices is not covered by the Titan Tire Warranty Policy.

CT - Contact Titan Technical services

HL - High Lift, extended booms, etc.

Load and Inflation Tables

20.5R25 Loader Usage Chart continued

For Standard Loader Service: <250 ft, < 5 mph

Manufacturer	Model	Bucket	Front Minimum Load Rating	Front Minimum Inflation	Rear Minimum Load Rating	Rear Minimum Inflation
		Cu.Yd.		Psi		Psi
Komatsu	WA320-3	4.2	1*	80	1*	60
Komatsu	WA320-6	3.7	1*	75	1*	60
Komatsu	WA320PZ-6	3.5	1*	80	1*	60
Komatsu	WA320-7	3.7	1*	80	1*	60
Komatsu Dresser	520CH	2.5	1*	60	1*	60
Komatsu Dresser	525	2.7	1*	60	1*	60
Komatsu Dresser	530	3	1*	65	1*	60
Komatsu Dresser	530C	3	1*	65	1*	60
Komatsu Dresser	532	3.2	1*	70	1*	60
Liebherr	L538 Z-bar	3.4	1*	70	1*	60
Liebherr	L538	3	1*	65	1*	60
Liebherr	L538 HL	3	1*	70	1*	60
Liebherr	L542 Z-bar	3.7	1*	75	1*	60
Liebherr	L542	3.3	1*	70	1*	60
Liebherr	L542 HL	3.3	1*	75	1*	60
New Holland	W170B	3	1*	65	1*	60
New Holland	W170B TC/LR	3	1*	65	1*	60
Terex	55C	3	1*	65	1*	60
Terex	TL210	4.6	1*	85	1*	60
Terex	TL260	5.9	2*	CT	1*	70
Volvo	L60F	2.7	1*	60	1*	60
Volvo	L60G	2.75	1*	60	1*	60
Volvo	L60H	2.75	1*	60	1*	60
Volvo	L70B	2.1	1*	60	1*	60
Volvo	L70C	2.5	1*	60	1*	60
Volvo	L70D	2.5	1*	60	1*	60
Volvo	L70F	3	1*	65	1*	60
Volvo	L70G	3	1*	65	1*	60
Volvo	L70H	3	1*	70	1*	60
Volvo	L90B	3	1*	65	1*	60
Volvo	L90C	3.5	1*	75	1*	60
Volvo	L90D	3.5	1*	80	1*	60
Volvo	L90E	3.25	1*	75	1*	60
Volvo	L90F	3.5	1*	80	1*	60
Volvo	L90G	3.25	1*	75	1*	60
Volvo	L90H	3.25	1*	75	1*	60

For service under chains, or load and carry operations, contact Titan Technical Services.

Pressure and ply recommendations based on normal quarry operations with standard equipment. For different applications, or modified equipment, please contact OTR Field Engineering for a specific recommendation. Tire damage or failure caused by improper load, ply, speed or inflation practices is not covered by the Titan Tire Warranty Policy.

CT - Contact Titan Technical services

HL - High Lift, extended booms, etc.

23.5R25 Loader Usage Chart

For Standard Loader Service: <250 ft, < 5 mph

Manufacturer	Model	Bucket	Front	Front	Rear	Rear
			Minimum Load Rating	Minimum Inflation	Minimum Load Rating	Minimum Inflation
		Cu.Yd.		Psi		Psi
Caterpillar	924K	2.5	1*	60	1*	60
Caterpillar	926M	2.5	1*	60	1*	60
Caterpillar	930K	2.75	1*	60	1*	60
Caterpillar	930M	2.75	1*	60	1*	60
Caterpillar	938K	3.25	1*	60	1*	60
Caterpillar	938M	3.25	1*	60	1*	60
Caterpillar	950F TC	4	1*	70	1*	60
Caterpillar	950E	4	1*	70	1*	60
Caterpillar	950F-II	4	1*	70	1*	60
Caterpillar	950G	3.9	1*	70	1*	60
Caterpillar	950G -II	2.7	1*	60	1*	60
Caterpillar	950H	4	1*	70	1*	60
Caterpillar	950K	4	1*	65	1*	60
Caterpillar	950L	7.5	1*	70	1*	60
Caterpillar	950M	4.5	1*	80	1*	60
Caterpillar	960F	4.5	1*	80	1*	60
Caterpillar	962G	4.25	1*	75	1*	60
Caterpillar	962H	4.25	1*	75	1*	60
Caterpillar	962K	4.4	1*	70	1*	60
Caterpillar	962L	3.9	1*	70	1*	60
Caterpillar	962M	4.7	1*	85	1*	60
Caterpillar	966C	4	1*	70	1*	60
Caterpillar	966D	4.25	1*	80	1*	60
Caterpillar	IT62H	4.25	1*	75	1*	60
Case	821	3.5	1*	60	1*	60
Case	821B	3.5	1*	60	1*	60
Case	821C	3.5	1*	60	1*	60
Case	821E	4.5	1*	70	1*	60
Case	821E XR	4.5	1*	75	1*	60
Case	821F	3.5	1*	65	1*	60
Case	821F XR	3.5	1*	65	1*	60
Case	921F	4.75	1*	80	1*	60
Case	921F XR	4.75	1*	85	1*	60
Case	W36	4	1*	65	1*	60
Daewoo	Mega 300	3.8	1*	65	1*	60
Daewoo	Mega 300-III	2.9	1*	60	1*	60
Deere	644D	3.2	1*	60	1*	60
Deere	644E	3.2	1*	60	1*	60
Deere	644G	4	1*	65	1*	60
Deere	644H	4.25	1*	70	1*	60
Deere	644H-HL	4.25	1*	70	1*	60
Deere	644H-MH	4.5	1*	70	1*	60
Deere	644H-WH	6	1*	90	1*	60
Deere	644K	4.25	1*	70	1*	60

For service under chains, or load and carry operations, contact Titan Technical Services.

Pressure and ply recommendations based on normal quarry operations with standard equipment. For different applications, or modified equipment, please contact OTR Field Engineering for a specific recommendation. Tire damage or failure caused by improper load, ply, speed or inflation practices is not covered by the Titan Tire Warranty Policy.

CT - Contact Titan Technical services

HL - High Lift, extended booms, etc.

Load and Inflation Tables

23.5R25 Loader Usage Chart continued

For Standard Loader Service: <250 ft, < 5 mph

Manufacturer	Model	Bucket	Front Minimum Load Rating	Front Minimum Inflation	Rear Minimum Load Rating	Rear Minimum Inflation
		Cu.Yd.		Psi		Psi
Deere	644K-HL	4.25	1*	75	1*	60
Deere	644K-WH	5	1*	85	1*	60
Deere	724J	4.75	1*	75	1*	60
Deere	724J-HL	4.25	1*	75	1*	60
Deere	724K	4.75	1*	75	1*	60
Deere	724K-HL	4.25	1*	75	1*	60
Doosan	DL300	4.2	1*	70	1*	60
Doosan	DL300-5	4.2	1*	70	1*	60
Doosan	DL300-5 HL	4.2	1*	75	1*	60
Doosan	DL350-5	4.8	1*	80	1*	60
Doosan	DL350-5 HL	4.8	1*	85	1*	60
Fiattalis	FR160	3.6	1*	60	1*	60
Fiattalis	FR160-2	4	1*	65	1*	60
Fiattalis	FR180	4	1*	65	1*	60
Fiattalis	FR180-2	4	1*	65	1*	60
Fiattalis	FR20	4.5	1*	75	1*	60
Fiattalis	FR20B	4.6	1*	80	1*	60
Fiat Hitachi	W190	3.3	1*	60	1*	60
Fiat Hitachi	W230	4.6	1*	75	1*	60
Fiat Hitachi	FR160-2	4	1*	65	1*	60
Hitachi	ZW220	4.2	1*	70	1*	60
Hitachi	ZW220 HL	3.5	1*	65	1*	60
Hitachi	ZW250	4.5	1*	75	1*	60
Hitachi	ZW250 HL	4	1*	75	1*	60
Hyundai	HL760	4	1*	70	1*	60
Hyundai	HL760-7A	4	1*	70	1*	60
Hyundai	HL760XTD-7A	4	1*	75	1*	60
Hyundai	HL760-9	4.3	1*	70	1*	60
Hyundai	HL760XTD-9	4.3	1*	75	1*	60
Hyundai	HL760-9A	4.3	1*	70	1*	60
Hyundai	HL760XTD-9A	4.3	1*	75	1*	60
Hyundai	HL770-7	5.2	1*	90	1*	60
Hyundai	HL770XTD-7	5.2	2*	CT	1*	60
Hyundai	HL770-7A	4	1*	75	1*	60
Hyundai	HL770XTD-7A	4	1*	80	1*	60
Hyundai	HL770-9	5.5	2*	CT	1*	60
Hyundai	HL770XTD-9	5.5	2*	CT	1*	60
Hyundai	HL770-9A	5.5	2*	CT	1*	60
Hyundai	HL770XTD-9A	5.5	2*	CT	1*	60
Hyundai	HL960	3.8	1*	70	1*	60
Hyundai	HL960 XT	3.8	1*	70	1*	60
Hyundai	HL970	4.7	1*	85	1*	60
Hyundai	HL970 XTD	4.7	1*	90	1*	60
Hyundai	HL35	4.8	1*	85	1*	60
JCB	456ZX	4.3	1*	75	1*	60

For service under chains, or load and carry operations, contact Titan Technical Services.

Pressure and ply recommendations based on normal quarry operations with standard equipment. For different applications, or modified equipment, please contact OTR Field Engineering for a specific recommendation. Tire damage or failure caused by improper load, ply, speed or inflation practices is not covered by the Titan Tire Warranty Policy.

CT - Contact Titan Technical services

HL - High Lift, extended booms, etc.

23.5R25 Loader Usage Chart continued

For Standard Loader Service: <250 ft, < 5 mph

Manufacturer	Model	Bucket	Front	Front	Rear	Rear
			Minimum Load Rating	Minimum Inflation	Minimum Load Rating	Minimum Inflation
		Cu.Yd.		Psi		Psi
Kawasaki	70ZV-2	3.5	1*	60	1*	60
Kawasaki	70ZV-2 HL	3.5	1*	60	1*	60
Kawasaki	70TMV-2	3.4	1*	65	1*	60
Kawasaki	70Z7	3.7	1*	60	1*	60
Kawasaki	70Z7 HL	3.7	1*	65	1*	60
Kawasaki	80Z	3.75	1*	65	1*	60
Kawasaki	80ZII	3.75	1*	65	1*	60
Kawasaki	80ZIII	3.75	1*	65	1*	60
Kawasaki	80ZIV	3.75	1*	65	1*	60
Kawasaki	80ZIV-2	4	1*	65	1*	60
Kawasaki	80ZV-2	4.2	1*	70	1*	60
Kawasaki	80Z7	4.2	1*	70	1*	60
Kawasaki	80Z7 HL	4.2	1*	75	1*	60
Kawasaki	85Z7	4.8	1*	80	1*	60
Kawasaki	85Z7 HL	4.8	1*	85	1*	60
Kawasaki	90Z7	5.5	2*	CT	1*	60
Kawasaki	90Z7 HL	5.5	2*	CT	1*	65
Kawasaki	90Z7B	5.5	2*	CT	1*	60
Kawasaki	90Z7B HL	5.5	2*	CT	1*	65
Komatsu	WA380-3	5.25	1*	80	1*	60
Komatsu	WA380-6	4.3	1*	70	1*	60
Komatsu	WA380-7	4.3	1*	70	1*	60
Komatsu	WA380-7 HL	3.8	1*	70	1*	60
Komatsu	WA430-6	4.6	1*	75	1*	60
Komatsu Dresser	538	4	1*	70	1*	60
Komatsu Dresser	540	4.5	1*	70	1*	60
Liebherr	L550	4.2	1*	70	1*	60
Liebherr	L550 HL	3.4	1*	70	1*	60
Liebherr	L556	4.7	1*	75	1*	60
Liebherr	L556 HL	3.7	1*	70	1*	60
New Holland	W190B	3.44	1*	60	1*	60
New Holland	W190B LR	3.44	1*	65	1*	60
Terex	66C	4	1*	75	1*	60
Terex	70C	4.4	1*	75	1*	60
Terex	TL310	4	1*	70	1*	60
Volvo	L110F	4.4	1*	75	1*	60
Volvo	L110H	4	1*	70	1*	60
Volvo	L120B	3.9	1*	60	1*	60
Volvo	L120C	4.7	1*	75	1*	60
Volvo	L120D	4.7	1*	80	1*	60
Volvo	L120F	4.7	1*	80	1*	60
Volvo	L120H	4.25	1*	75	1*	60
Volvo	L150	4.5	1*	80	1*	60
Volvo	L150C	5.2	1*	85	1*	60
Volvo	L150D	5.2	2*	CT	1*	60

For service under chains, or load and carry operations, contact Titan Technical Services.

Pressure and ply recommendations based on normal quarry operations with standard equipment. For different applications, or modified equipment, please contact OTR Field Engineering for a specific recommendation. Tire damage or failure caused by improper load, ply, speed or inflation practices is not covered by the Titan Tire Warranty Policy.

CT - Contact Titan Technical services

HL - High Lift, extended booms, etc.

Load and Inflation Tables

26.5R25 Loader Usage Chart

For Standard Loader Service: <250 ft, < 5 mph

Manufacturer	Model	Bucket	Front Minimum Load Rating	Front Minimum Inflation	Rear Minimum Load Rating	Rear Minimum Inflation
		Cu.Yd.		Psi		Psi
Caterpillar	966E	5	1*	70	1*	60
Caterpillar	966F	5	1*	70	1*	60
Caterpillar	966F-II	5	1*	70	1*	60
Caterpillar	966G	4.75	1*	70	1*	60
Caterpillar	966H	5.5	1*	75	1*	60
Caterpillar	966H	5.75	1*	75	1*	60
Caterpillar	966K	5.5	1*	80	1*	60
Caterpillar	966L	5.5	1*	75	1*	60
Caterpillar	966M	5.5	1*	75	1*	60
Caterpillar	966M XE	5.5	1*	75	1*	60
Caterpillar	970F	5.25	1*	75	1*	60
Caterpillar	972G	5.4	1*	75	1*	60
Caterpillar	972H	5.5	1*	75	1*	60
Caterpillar	972K	5.5	1*	80	1*	60
Caterpillar	972L	5.5	1*	80	1*	60
Caterpillar	972M	6.3	1*	85	1*	60
Caterpillar	972M XE	6	1*	80	1*	60
Case	921	4.75	1*	65	1*	60
Case	921B	4.75	1*	65	1*	60
Case	921C	4.75	1*	65	1*	60
Case	921E	5.75	1*	75	1*	60
Case	921E XR	5.75	1*	80	1*	60
Case	921F	4.75	1*	65	1*	60
Case	921F XR	4.75	1*	65	1*	60
Daewoo	Mega 400	5.1	1*	70	1*	60
Daewoo	Mega 400-III	3.9	1*	65	1*	60
Deere	744E	5	1*	70	1*	60
Deere	744H	5.25	1*	70	1*	60
Deere	744H-HL	4.5	1*	70	1*	60
Deere	744H-MH	5.75	1*	80	1*	60
Deere	744J	5.25	1*	75	1*	60
Deere	744J HL	5.25	1*	80	1*	60
Deere	744K	5.25	1*	75	1*	60
Deere	744K-HL	5.25	1*	80	1*	60
Deere	744K-II	5.25	1*	75	1*	60
Deere	744K-II HL	5.25	1*	80	1*	60
Deere	824J	6	1*	85	1*	60
Deere	824J HL	5.25	1*	80	1*	60
Deere	824K	6	1*	85	1*	60
Deere	824K-HL	6	1*	85	1*	60
Deere	824K-II	6	1*	85	1*	60
Deere	824K-II HL	6	1*	90	1*	60
Deere	844	6	1*	80	1*	60
Doosan	DL400	5.1	1*	70	1*	60
Doosan	DL420-5	5.5	1*	75	1*	60

For service under chains, or load and carry operations, contact Titan Technical Services.

Pressure and ply recommendations based on normal quarry operations with standard equipment. For different applications, or modified equipment, please contact OTR Field Engineering for a specific recommendation. Tire damage or failure caused by improper load, ply, speed or inflation practices is not covered by the Titan Tire Warranty Policy.

CT - Contact Titan Technical services

HL - High Lift, extended booms, etc.

26.5R25 Loader Usage Chart continued

For Standard Loader Service: <250 ft, < 5 mph

Manufacturer	Model	Bucket	Front Minimum Load Rating	Front Minimum Inflation	Rear Minimum Load Rating	Rear Minimum Inflation
		Cu.Yd.		Psi		Psi
Doosan	DL420-5 HL	5.5	1*	80	1*	60
Doosan	DL450	6.3	1*	85	1*	60
Doosan	DL450-3	5.88	1*	80	1*	60
Doosan	DL450-5	6.3	1*	85	1*	60
Doosan	DL450-5 HL	6.3	1*	85	1*	60
Fiatalis	FR220	5.1	1*	70	1*	60
Fiatalis	FR220-2	5	1*	70	1*	60
Fiat Hitachi	W270	5.2	1*	70	1*	60
Fiat Hitachi	FR220-2	5	1*	70	1*	60
Furukawa	FL330-I	4.3	1*	60	1*	60
Hitachi	ZW310	5.25	1*	70	1*	60
Hitachi	ZW310 HL	4.75	1*	70	1*	60
Hyundai	HL770	5	1*	75	1*	60
Hyundai	HL770-7	5.2	1*	70	1*	60
Hyundai	HL770XTD-7	5.2	1*	75	1*	60
Hyundai	HL770-7A	5.2	1*	70	1*	60
Hyundai	HL770XTD-7A	5.2	1*	75	1*	60
Hyundai	HL770-9	5.5	1*	75	1*	60
Hyundai	HL770XTD-9	5.5	1*	80	1*	60
Hyundai	HL770-9A	5.5	1*	75	1*	60
Hyundai	HL770XTD-9A	5.5	1*	80	1*	60
Hyundai	HL780-7A	6.7	2*	CT	1*	60
Hyundai	HL780XTD-7A	6.7	2*	CT	1*	60
Hyundai	HL780-9	7.1	2*	CT	1*	60
Hyundai	HL780XTD-9	7.1	2*	CT	1*	65
Hyundai	HL780-9A	7.1	2*	CT	1*	60
Hyundai	HL780XTD-9A	7.1	2*	CT	1*	65
Hyundai	HL970	4.7	1*	70	1*	60
Hyundai	HL970 XTD	4.7	1*	70	1*	60
Hyundai	HL980	6.3	2*	CT	1*	60
Hyundai	HL980 XTD	6.3	2*	CT	1*	60
Kawasaki	85Z	4.2	1*	60	1*	60
Kawasaki	85ZII	4.2	1*	60	1*	60
Kawasaki	85ZIII	4.3	1*	65	1*	60
Kawasaki	85ZIV	4.3	1*	60	1*	60
Kawasaki	85ZIV-2	4.75	1*	65	1*	60
Kawasaki	85ZV-2	4.8	1*	65	1*	60
Kawasaki	85Z7	4.8	1*	65	1*	60
Kawasaki	85Z7 HL	4.8	1*	70	1*	60
Kawasaki	90ZIII	5	1*	70	1*	60
Kawasaki	90ZIV	5	1*	70	1*	60
Kawasaki	90ZIV-2	5.5	1*	75	1*	60
Kawasaki	90ZV	5.2	1*	75	1*	60
Kawasaki	90ZV	4.25	1*	65	1*	60

For service under chains, or load and carry operations, contact Titan Technical Services.

Pressure and ply recommendations based on normal quarry operations with standard equipment. For different applications, or modified equipment, please contact OTR Field Engineering for a specific recommendation. Tire damage or failure caused by improper load, ply, speed or inflation practices is not covered by the Titan Tire Warranty Policy.

CT - Contact Titan Technical services

HL - High Lift, extended booms, etc.

Load and Inflation Tables

26.5R25 Loader Usage Chart continued

For Standard Loader Service: <250 ft, < 5 mph

Manufacturer	Model	Bucket	Front Minimum Load Rating	Front Minimum Inflation	Rear Minimum Load Rating	Rear Minimum Inflation
		Cu.Yd.		Psi		Psi
Kawasaki	90ZV-2	5.2	1*	70	1*	60
Kawasaki	90Z7	5.5	1*	75	1*	60
Kawasaki	90Z7 HL	5.5	1*	80	1*	60
Kawasaki	90Z7B	5.5	1*	75	1*	60
Kawasaki	90Z7B HL	5.5	1*	80	1*	60
Kawasaki	92ZV-2	6	1*	85	1*	60
Kawasaki	92Z7	6.3	1*	85	1*	60
Kawasaki	92Z7 HL	6.3	2*	CT	1*	60
Kawasaki	95ZV-2	7	2*	CT	1*	65
Komatsu	WA420-1	4.75	1*	65	1*	60
Komatsu	WA420-3	6	1*	70	1*	60
Komatsu	WA430-6	4.6	1*	60	1*	60
Komatsu	WA450-2	5.5	1*	75	1*	60
Komatsu	WA450-3	6.8	1*	85	1*	60
Komatsu	WA470-6	5.5	1*	75	1*	60
Komatsu	WA470-7	5.5	1*	75	1*	60
Komatsu	WA470-8	5	1*	75	1*	60
Komatsu	WA480-6	6	1*	80	1*	60
Komatsu Dresser	542	4.75	1*	65	1*	60
Komatsu Dresser	545	5.5	1*	80	1*	60
Komatsu Dresser	550	5.25	1*	75	1*	60
Liebherr	L566	5.2	1*	70	1*	60
Liebherr	L566 HL	4.6	1*	70	1*	60
Liebherr	L580	6.5	1*	85	1*	60
Liebherr	L580 HL	5.9	1*	80	1*	60
Terex	80C	5.5	1*	80	1*	60
Volvo	L150C	5.2	1*	70	1*	60
Volvo	L150D	5.2	1*	75	1*	60
Volvo	L150F	5.8	1*	80	1*	60
Volvo	L150G	6.8	1*	90	1*	60
Volvo	L150H	5.25	1*	75	1*	60
Volvo	L180	5.5	1*	75	1*	60
Volvo	L180C	6	1*	80	1*	60
Volvo	L180D	6.3	1*	85	1*	60
Volvo	L180F	6.3	1*	85	1*	60
Volvo	L180G	7.6	2*	CT	1*	60
Volvo	L180H	5.75	1*	85	1*	60
Volvo	L190	5.2	1*	80	1*	60
Volvo	L190B	5.2	1*	80	1*	60

For service under chains, or load and carry operations, contact Titan Technical Services.

Pressure and ply recommendations based on normal quarry operations with standard equipment. For different applications, or modified equipment, please contact OTR Field Engineering for a specific recommendation. Tire damage or failure caused by improper load, ply, speed or inflation practices is not covered by the Titan Tire Warranty Policy.

CT - Contact Titan Technical services

HL - High Lift, extended booms, etc.

29.5R25 Loader Usage Chart

For Standard Loader Service: <250 ft, < 5 mph

Manufacturer	Model	Bucket	Front	Front	Rear	Rear
			Minimum Load Rating	Minimum Inflation	Minimum Load Rating	Minimum Inflation
		Cu.Yd.		Psi		Psi
Caterpillar	980C	6.75	1*	80	1*	60
Caterpillar	980F	7	1*	80	1*	60
Caterpillar	980F-II	7	1*	80	1*	60
Caterpillar	980G	7	1*	85	1*	60
Caterpillar	980H	7.5	1*	85	1*	60
Caterpillar	980K	7.5	1*	85	1*	60
Caterpillar	980M	7.5	1*	80	1*	60
Case	1221E	9.2	1*	60	1*	60
Case	1221E XR	9.2	1*	60	1*	60
Deere	744J	5.25	1*	60	1*	60
Deere	744J HL	5.25	1*	65	1*	60
Deere	824J	6	1*	70	1*	60
Deere	824J HL	5.25	1*	70	1*	60
Deere	824K	6	1*	70	1*	60
Deere	824K HL	6	1*	75	1*	60
Deere	824K-II	6	1*	70	1*	60
Deere	824K-II HL	6	1*	75	1*	60
Deere	844J	7.25	1*	85	1*	60
Deere	844K	7.25	1*	85	1*	60
Deere	844K-II	7.25	1*	85	1*	60
Doosan	DL500	6.8	1*	80	1*	60
Doosan	DL550-5	7.5	1*	85	1*	60
Doosan	DL550-5 HL	7.5	2*	CT	1*	60
Furukawa	FL460	6	1*	75	1*	60
Hyundai	HL780-7A	6.7	1*	75	1*	60
Hyundai	HL780XTD-7A	6.7	1*	80	1*	60
Hyundai	HL780-9	7.1	1*	80	1*	60
Hyundai	HL780XTD-9	7.1	1*	85	1*	60
Hyundai	HL780-9A	7.1	1*	80	1*	60
Hyundai	HL780XTD-9A	7.1	1*	85	1*	60
Hyundai	HL980	6.3	1*	75	1*	60
Hyundai	HL980 XTD	6.3	1*	80	1*	60
Kawasaki	95Z	6	1*	70	1*	60
Kawasaki	95ZII	6	1*	70	1*	60
Kawasaki	95ZIII	6.5	1*	80	1*	60
Kawasaki	95ZIV	6.5	1*	75	1*	60
Kawasaki	95ZIV-2	7.25	1*	80	1*	60
Kawasaki	95ZIV-3	7.25	1*	80	1*	60
Kawasaki	95ZV-2	7	1*	80	1*	60
Kawasaki	95Z7	7.3	1*	90	1*	60
Kawasaki	95Z7 HL	7.3	2*	CT	1*	60
Komatsu	WA500-1	6	1*	75	1*	60
Komatsu	WA500-3	7.2	1*	80	1*	60
Komatsu	WA500-6	7.3	1*	85	1*	60

For service under chains, or load and carry operations, contact Titan Technical Services.

Pressure and ply recommendations based on normal quarry operations with standard equipment. For different applications, or modified equipment, please contact OTR Field Engineering for a specific recommendation. Tire damage or failure caused by improper load, ply, speed or inflation practices is not covered by the Titan Tire Warranty Policy.

CT - Contact Titan Technical services

HL - High Lift, extended booms, etc.

Load and Inflation Tables

29.5R25 Loader Usage Chart continued

For Standard Loader Service: <250 ft, < 5 mph

Manufacturer	Model	Bucket	Front Minimum Load Rating	Front Minimum Inflation	Rear Minimum Load Rating	Rear Minimum Inflation
		Cu.Yd.		Psi		Psi
Komatsu	WA500-7	7.3	1*	85	1*	60
Komatsu	WA500-7 HL	5.9	1*	80	1*	60
Komatsu	WA500-7 SM	5.25	1*	80	1*	60
Komatsu Dresser	555	6	1*	80	1*	60
Komatsu Dresser	558	6	1*	75	1*	60
Volvo	L190	5.2	1*	65	1*	60
Volvo	L190B	5.2	1*	65	1*	60
Volvo	L220D	7	1*	75	1*	60
Volvo	L220E	7.1	1*	85	1*	60
Volvo	L220F	7.8	1*	90	1*	60
Volvo	L220G	8.2	2*	CT	1*	60
Volvo	L220H	6.8	1*	80	1*	60

750/65R25 Loader Usage Chart

For Standard Loader Service: <250 ft, < 5 mph

Manufacturer	Model	Bucket	Front Minimum Load Rating	Front Minimum Inflation	Rear Minimum Load Rating	Rear Minimum Inflation
		Cu.Yd.		Psi		Psi
Caterpillar	950K	4	1*	60	1*	60
Caterpillar	950M	4.5	1*	65	1*	60
Caterpillar	962K	4.5	1*	65	1*	60
Caterpillar	962M	4.7	1*	65	1*	60
Caterpillar	966H	4.75	1*	65	1*	60
Caterpillar	972H	5.5	1*	75	1*	60
Deere	644K	4.25	1*	60	1*	60
Deere	644K-HL	4.25	1*	60	1*	60
Deere	724J	4.75	1*	60	1*	60
Deere	724J-HL	4.25	1*	60	1*	60
Deere	724K	4.75	1*	60	1*	60
Deere	724K-HL	4.75	1*	65	1*	60
Kawasaki	85Z7	4.8	1*	65	1*	60
Kawasaki	85Z7 HL	4.8	1*	65	1*	60
Kawasaki	90Z7	5.5	1*	75	1*	60
Kawasaki	90Z7 HL	5.5	1*	80	1*	60
Kawasaki	90Z7B	5.5	1*	70	1*	60
Kawasaki	90Z7B HL	5.5	1*	75	1*	60
Kawasaki	92Z7	6.3	1*	85	1*	60
Kawasaki	92Z7 HL	6.3	2*	CT	1*	60
Volvo	L110H	4	1*	60	1*	60
Volvo	L120H	4.25	1*	60	1*	60

For service under chains, or load and carry operations, contact Titan Technical Services.

Pressure and ply recommendations based on normal quarry operations with standard equipment. For different applications, or modified equipment, please contact OTR Field Engineering for a specific recommendation. Tire damage or failure caused by improper load, ply, speed or inflation practices is not covered by the Titan Tire Warranty Policy.

CT - Contact Titan Technical services

HL - High Lift, extended booms, etc.

875/65R29 Loader Usage Chart

For Standard Loader Service: < 250 ft, < 5 mph

Manufacturer	Model	Bucket	Front Minimum Load Rating	Front Minimum Inflation	Rear Minimum Load Rating	Rear Minimum Inflation
		Cu.Yd.		Psi		Psi
Caterpillar	982M	8	1*	75	1*	60
Deere	844K-II	7.25	1*	70	1*	60
Kawasaki	95Z7 Xtreme	7.7	1*	75	1*	60
Volvo	L220H	6.8	1*	65	1*	60

35/65R33 Loader Usage Chart

For Standard Loader Service: < 250 ft, < 5 mph

Pit Loader Application						
Manufacturer	Model	Bucket	Front Minimum Load Rating	Front Minimum Inflation	Rear Minimum Load Rating	Rear Minimum Inflation
		Cu.Yd.		Psi		Psi
Caterpillar	986H	6.12	1*	80	1*	65
Caterpillar	986H HL	5.35	1*	80	1*	65
Caterpillar	988B	8.25	2*	100	1*	65
Caterpillar	988F	7.75	2*	100	1*	65
Caterpillar	988G	8	2*	110	1*	70
Caterpillar	988H	8.2	2*	110	1*	70
Caterpillar	988H	8.33	2*	110	1*	70
Caterpillar	988H	9.2	CT	CT	2*	75
Caterpillar	988H HL	8.33	2*	110	1*	70
Caterpillar	988K	8.4	2*	110	1*	70
Caterpillar	988K HL	8.4	CT	CT	1*	75
Kawasaki	110Z	7.5	2*	90	1*	65
Kawasaki	110ZII	7.5	2*	90	1*	65
Kawasaki	115ZIII	7.5	2*	90	1*	65
Kawasaki	115ZIV	7.5	2*	95	1*	65
Kawasaki	115ZIV-2	8.25	2*	105	1*	65
Kawasaki	115ZV	7.5	2*	95	1*	65
Kawasaki	115ZV-2	8.3	2*	100	1*	65
Kawasaki	115ZV-2 HL	6.5	1*	90	1*	65
Kawasaki	115Z7	8.3	2*	100	1*	65
Kawasaki	115Z7 HL	9	2*	110	1*	70
Kawasaki	115Z7 Xtreme	9.15	2*	105	1*	70
Komatsu	WA600-1	7.1	1*	85	1*	65
Komatsu	WA600-3	8	2*	95	1*	65
Komatsu	WA600-6	8.4	2*	110	1*	70
Komatsu	WA600-6	9.5	CT	CT	2*	75
Komatsu Dresser	568	7.5	2*	90	1*	65
O&K	7500	7	1*	90	1*	65
Sandvik	LH621-10	10.5	CT	CT	1*	75
Terex	90C	8.5	2*	100	1*	65
Volvo	L320	8	2*	100	1*	65
Volvo	L330C	8.6	2*	105	1*	70
Volvo	L330D	8.6	2*	105	1*	70
Volvo	L330E	8.6	2*	105	1*	70
Volvo	L350F	10.1	CT	CT	2*	80

Yard Loader Application						
Manufacturer	Model	Bucket	Front Minimum Load Rating	Front Minimum Inflation	Rear Minimum Load Rating	Rear Minimum Inflation
		Cu.Yd.		Psi		Psi
Caterpillar	986H	6.12	1*	70	1*	65
Caterpillar	986H HL	5.35	1*	70	1*	65
Caterpillar	988B	8.25	1*	90	1*	65
Caterpillar	988F	7.75	1*	85	1*	65
Caterpillar	988G	8	2*	95	1*	65
Caterpillar	988H	8.2	2*	95	1*	65
Caterpillar	988H	8.33	2*	95	1*	65
Caterpillar	988H	9.2	2*	100	1*	65
Caterpillar	988H HL	8.33	2*	95	1*	65
Caterpillar	988K	8.4	2*	95	1*	65
Caterpillar	988K HL	8.4	2*	100	1*	65
Kawasaki	110Z	7.5	1*	80	1*	65
Kawasaki	110ZII	7.5	1*	80	1*	65
Kawasaki	115ZIII	7.5	1*	80	1*	65
Kawasaki	115ZIV	7.5	1*	85	1*	65
Kawasaki	115ZIV-2	8.25	1*	90	1*	65
Kawasaki	115ZV	7.5	1*	85	1*	65
Kawasaki	115ZV-2	8.3	1*	90	1*	65
Kawasaki	115ZV-2 HL	6.5	1*	80	1*	65
Kawasaki	115Z7	8.3	1*	85	1*	65
Kawasaki	115Z7 HL	9	2*	95	1*	65
Kawasaki	115Z7 Xtreme	9.15	1*	90	1*	65
Komatsu	WA600-1	7.1	1*	75	1*	65
Komatsu	WA600-3	8	1*	80	1*	65
Komatsu	WA600-6	8.4	2*	95	1*	65
Komatsu	WA600-6	9.5	2*	100	1*	65
Komatsu Dresser	568	7.5	1*	80	1*	65
O&K	7500	7	1*	80	1*	65
Sandvik	LH621-10	10.5	CT	CT	1*	75
Terex	90C	8.5	1*	85	1*	65
Volvo	L320	8	1*	85	1*	65
Volvo	L330C	8.6	2*	90	1*	65
Volvo	L330D	8.6	2*	90	1*	65
Volvo	L330E	8.6	2*	95	1*	65
Volvo	L350F	10.1	2*	100	1*	65

For service under chains, or load and carry operations, contact Titan Technical Services.

Pressure and ply recommendations based on normal quarry operations with standard equipment. For different applications, or modified equipment, please contact OTR Field Engineering for a specific recommendation. Tire damage or failure caused by improper load, ply, speed or inflation practices is not covered by the Titan Tire Warranty Policy.

CT - Contact Titan Technical services
 HL - High Lift, extended booms, etc.

Load and Inflation Tables

45/65R45 Loader Usage Chart

For Standard Loader Service: <250 ft, < 5 mph

Manufacturer	Model	Bucket	Front Minimum Load Rating	Front Minimum Inflation	Rear Minimum Load Rating	Rear Minimum Inflation
		Cu.Yd.		Psi		Psi
Caterpillar	992B	10	1*	75	1*	65
Caterpillar	992C	12.5	2*	100	1*	65
Caterpillar	992C HL	12.5	2*	105	1*	70
Caterpillar	992D	14	2*	105	1*	65
Caterpillar	992D HL	12	2*	100	1*	65
Caterpillar	992G	15	2*	110	1*	70
Caterpillar	992G HL	15	CT	CT	1*	75
Caterpillar	992K	14	2*	110	1*	70
Caterpillar	992K HL	14	2*	105	1*	65
Komatsu	WA800-2	13.7	2*	100	1*	65
Komatsu	WA800-3	14.4	2*	105	1*	70
Komatsu	WA900-3	17	CT	CT	2*	85
Komatsu	WA900-3 HL	15	CT	CT	2*	80
LeTourneau	L-950-2	18	2*	105	1*	70
LeTourneau	L-950-2 HL	16	2*	105	1*	65
LeTourneau	L1000	17	CT	CT	2*	75

50/65R51 Loader Usage Chart

For Standard Loader Service: <250 ft, < 5 mph

Manufacturer	Model	Bucket	Front Minimum Load Rating	Front Minimum Inflation	Rear Minimum Load Rating	Rear Minimum Inflation
		Cu.Yd.		Psi		Psi
Caterpillar	993K	17	CT	CT	1*	75
Caterpillar	993K HL	17	CT	CT	2*	80
Caterpillar	993K HL	19	CT	CT	2*	85
Letourneau	L-1100	22	CT	CT	1*	75
Letourneau	L-1100 HL	20	2*	110	1*	70
Letourneau	L-1150-2	25	CT	CT	2*	80
Letourneau	L-1150-2 HL	23	CT	CT	2*	80

For service under chains, or load and carry operations, contact Titan Technical Services.

Pressure and ply recommendations based on normal quarry operations with standard equipment. For different applications, or modified equipment, please contact OTR Field Engineering for a specific recommendation. Tire damage or failure caused by improper load, ply, speed or inflation practices is not covered by the Titan Tire Warranty Policy.

CT - Contact Titan Technical services

HL - High Lift, extended booms, etc.

58/80R63 Loader Usage Chart

For Standard Loader Service: <250 ft, < 5 mph

Manufacturer	Model	Bucket Cu.Yd.	Front Minimum Load Rating	Front Minimum Inflation	Rear Minimum Load Rating	Rear Minimum Inflation
				Psi		Psi
Caterpillar	994F STD (Tier 1)	25	2*	110	2*	80
Caterpillar	994F HL (Tier 1)	22.5	2*	110	2*	80
Caterpillar	994F EHL (Tier 1)	22.5	2*	115	2*	80
Caterpillar	994F SHL (Tier 1)	22.5	2*	115	2*	80
Caterpillar	994H STD	25	2*	105	2*	80
Caterpillar	994H HL	22.5	2*	110	2*	80
Caterpillar	994H EHL	22.5	2*	115	2*	80
Caterpillar	994H SHL	22.5	2*	120	2*	80
Caterpillar	994K	25	2*	120	2*	80
Caterpillar	994K HL	22.5	2*	120	2*	80
Komatsu	WA1200-3	26.2	2*	110	2*	80
Komatsu	WA1200-3 HL	23.5	2*	110	2*	80
Komatsu	WA1200-6 Rock	26.2	2*	115	2*	80
Komatsu	WA1200-6 Coal	45.8	2*	115	2*	80
Komatsu	WA1200-6 HL Rock	23.5	2*	115	2*	80
Komatsu	WA1200-6 HL Coal	45.8	2*	115	2*	80
LeTourneau	L-1850 STD	40	2*	120	2*	80
LeTourneau	L-1850 HL	30	2*	120	2*	80

For service under chains, or load and carry operations, contact Titan Technical Services.

Pressure and ply recommendations based on normal quarry operations with standard equipment. For different applications, or modified equipment, please contact OTR Field Engineering for a specific recommendation. Tire damage or failure caused by improper load, ply, speed or inflation practices is not covered by the Titan Tire Warranty Policy.

CT - Contact Titan Technical services

HL - High Lift, extended booms, etc.

Load and Inflation Tables

18.00R33 Rigid Truck Usage Chart

For Standard Earthmover Service: <2.5 mile, < 30 mph

Manufacturer	Model	Bucket	Front Minimum Load Rating	Front Minimum Inflation	Rear Minimum Load Rating	Rear Minimum Inflation
		Tons		Psi		Psi
Astra	RD 40C	44.1	2*	115	2*	115
Caterpillar	769B	35	2*	95	2*	90
Caterpillar	769C	40	2*	110	2*	110
Caterpillar	769D	35	2*	110	2*	110
Caterpillar	770	40	CT	CT	2*	115
Caterpillar	770F	49	2*	115	2*	115
Caterpillar	770G	50	2*	115	2*	CT
Caterpillar	771C Quarry	44	CT	CT	CT	CT
Caterpillar	771D	45	CT	CT	CT	CT
Euclid	R35	35	2*	105	2*	105
Euclid	R36	40	2*	95	2*	100
Euclid	R40	41.5	2*	110	2*	110
Euclid	R40C	41.9	2*	115	2*	115
Hitachi	EH650	40	2*	95	2*	100
Hitachi	EH700	42	2*	115	2*	115
Hitachi	EH750	42.5	CT	CT	CT	CT
Hitachi	EH750-3	46.2	CT	CT	CT	CT
Komatsu	HD325-3	35	2*	85	2*	95
Komatsu	HD325-5	35	2*	85	2*	95
Komatsu	HD325-6 Quarry	44	2*	115	CT	CT
Komatsu	HD325-6 4WD	35	2*	100	2*	100
Komatsu	HD325-6	44	2*	105	2*	115
Komatsu	HD325-7	40	2*	110	2*	115
Komatsu	HD405-7	45	CT	CT	CT	CT
Komatsu Haulpak	140M	40	2*	110	2*	110
Perlini	DP 405 WD	44.1	2*	115	2*	115
Terex	3340	40	CT	CT	2*	115

24.00R35 Rigid Truck Usage Chart

For Standard Earthmover Service: <2.5 mile, < 30 mph

Manufacturer	Model	Bucket	Front Minimum Load Rating	Front Minimum Inflation	Rear Minimum Load Rating	Rear Minimum Inflation
		Tons		Psi		Psi
Caterpillar	773	50	2*	75	2*	70
Caterpillar	773B	58	2*	85	2*	85
Caterpillar	773D	50	2*	85	2*	85
Caterpillar	773E	60	2*	90	2*	90
Caterpillar	773F	60	2*	100	2*	90
Caterpillar	773G	54	2*	85	2*	85
Caterpillar	773G-4T	69.3	2*	105	2*	95
Caterpillar	775B Quarry	65	2*	95	2*	95
Caterpillar	775D	65	2*	95	2*	105
Caterpillar	775E	70	2*	95	2*	110
Caterpillar	775F	70	2*	105	2*	105
Caterpillar	775G	70	2*	110	2*	105

Pressure and ply recommendations based on normal quarry operations with standard equipment. For different applications, or modified equipment, please contact OTR Field Engineering for a specific recommendation. Tire damage or failure caused by improper load, ply, speed or inflation practices is not covered by the Titan Tire Warranty Policy.

CT - Contact Titan Technical services

Load and Inflation Tables

24.00R35 Rigid Truck Usage Chart Continued

For Standard Earthmover Service: <2.5 mile, < 30 mph

Manufacturer	Model	Payload	Front Minimum Load Rating	Front Minimum Inflation	Rear Minimum Load Rating	Rear Minimum Inflation
		Tons		Psi		Psi
Caterpillar	775G-4T	78.8	2*	110	2*	105
Dart	2085	85	1*	65	2*	75
Hitachi	EH1000	66	2*	95	2*	95
Hitachi	EH1100	72.3	2*	100	2*	105
Hitachi	EH1100-3	71.5	2*	100	2*	110
Hitachi	EH1100-5	70	2*	105	2*	105
Euclid	R50	58.1	2*	80	2*	80
Euclid	R60	63.1	2*	85	2*	90
Euclid	R60C	66	2*	105	2*	90
Euclid	R65	69.2	2*	95	2*	95
Euclid	R65C	71.1	2*	100	2*	105
Euclid	R75	75	2*	110	2*	105
Komatsu	HD465-3	51	2*	70	2*	75
Komatsu	HD465-5	61	2*	75	2*	80
Komatsu	HD465-5 Quarry	66	2*	95	2*	105
Komatsu	HD465-7	61	2*	90	2*	95
Komatsu	HD605-7	70	2*	100	2*	110
Komatsu-Haulpak	210M	60	2*	85	2*	85
Perlini	DP705 WD	71.6	2*	105	2*	105
Terex	3308E	55	2*	80	2*	80
Terex	3309	55	2*	90	2*	90
Terex	3310E	66	2*	100	2*	100
Terex	TR60	60	2*	90	2*	85
Terex	TR70	72	2*	110	2*	105

27.00R49 Rigid Truck Usage Chart

For Standard Earthmover Service: <2.5 mile, < 30 mph

Manufacturer	Model	Payload	Front Minimum Load Rating	Front Minimum Inflation	Rear Minimum Load Rating	Rear Minimum Inflation
		Tons		Psi		Psi
Caterpillar	777	85	2*	80	2*	85
Caterpillar	777B	95	2*	90	2*	95
Caterpillar	777C	95	2*	95	2*	95
Caterpillar	777D	100	2*	105	2*	105
Caterpillar	777F	100	2*	105	2*	105
Caterpillar	777G	100	2*	110	2*	110
Euclid	R85B	85	2*	90	2*	95
Euclid	R90	95.7	2*	95	2*	95
Euclid	R90C	100	2*	100	2*	100
Euclid	R100	100	2*	100	2*	105
Hitachi	EH1600	98.9	2*	105	2*	105
Hitachi	EH1700	108.4	2*	110	2*	115
Hitachi	EH1700-3	100	2*	105	2*	105
Komatsu	HD785-1	86	2*	80	2*	85

Pressure and ply recommendations based on normal quarry operations with standard equipment. For different applications, or modified equipment, please contact OTR Field Engineering for a specific recommendation. Tire damage or failure caused by improper load, ply, speed or inflation practices is not covered by the Titan Tire Warranty Policy.

CT - Contact Titan Technical services

Load and Inflation Tables

27.00R49 Rigid Truck Usage Chart Continued

For Standard Earthmover Service: <2.5 mile, < 30 mph

Manufacturer	Model	Payload	Front Minimum Load Rating	Front Minimum Inflation	Rear Minimum Load Rating	Rear Minimum Inflation
		Tons		Psi		Psi
Komatsu	HD785-3	86	2*	85	2*	90
Komatsu	HD785-3	100	2*	90	2*	100
Komatsu	HD785-5	106	2*	110	2*	110
Komatsu	HD785-7	100	2*	100	2*	110
Komatsu Haulpak	325M	95	2*	95	2*	95
Komatsu Haulpak	330M	100	2*	100	2*	105
Kress	CH160	160	2*	105	2*	105
Kress	CH180	180	2*	CT	2*	CT
Perlini	DP905	105	2*	100	2*	105
Rimpull	RD100	100	2*	95	2*	100
Rimpull	RD100C	100	2*	95	2*	105
Terex	3311C	85	2*	80	2*	80
Terex	3311D	77	2*	95	2*	80
Terex	3311E	94	2*	100	2*	90
Terex	TR100	100	2*	105	2*	100
Terex	TR100 (HR)	94	2*	105	2*	100
Terex	TR100 DD	100	2*	105	2*	100
Unit Rig	Dart 3100	100	2*	100	2*	105
Unit Rig	Dart 4160	160	1*	65	2*	95
Unit Rig	M85	85	2*	80	2*	80
Unit Rig	M100	100	2*	95	2*	95
Unit Rig	M120-15	120	2*	115	2*	115
Unit Rig	Mark 24	85	2*	95	2*	80

33.00R51 Rigid Truck Usage Chart

For Standard Earthmover Service: <2.5 mile, < 30 mph

Manufacturer	Model	Payload	Front Minimum Load Rating	Front Minimum Inflation	Rear Minimum Load Rating	Rear Minimum Inflation
		Tons		Psi		Psi
Belaz	75131	150	2*	110	2*	110
Belaz	75137NA	150	2*	110	2*	110
Caterpillar	785	155	2*	105	2*	105
Caterpillar	785B	155	2*	105	2*	105
Caterpillar	785C	150	2*	110	2*	115
Caterpillar	785D	157	2*	115	2*	115
Euclid	R120E	120	2*	75	2*	80
Euclid	R130	152	2*	95	2*	95
Euclid	R130B	146	2*	100	2*	100
Euclid	R130M	130	2*	80	2*	85
Euclid	R150	150	2*	105	2*	105
Komatsu Haulpak	510E	150	2*	105	2*	105
Komatsu Haulpak	530M	165	2*	110	2*	115
Komatsu	HD1500-7	159	2*	110	2*	115
Terex	MT3300	150	2*	110	2*	110
Terex	MT3300AC	150	2*	115	2*	115
Terex	MT3314B	125	2*	85	2*	85

Pressure and ply recommendations based on normal quarry operations with standard equipment. For different applications, or modified equipment, please contact OTR Field Engineering for a specific recommendation. Tire damage or failure caused by improper load, ply, speed or inflation practices is not covered by the Titan Tire Warranty Policy.

CT - Contact Titan Technical services

Load and Inflation Tables

37.00R57 Rigid Truck Usage Chart

For Standard Earthmover Service: <2.5 mile, < 30 mph

Manufacturer	Model	Payload	Front Minimum Load Rating	Front Minimum Inflation	Rear Minimum Load Rating	Rear Minimum Inflation
		Tons		Psi		Psi
CAT	789C	195	2*	105	2*	110
CAT	789D	200	2*	110	2*	110
Euclid	R190	190	2*	90	2*	95
Hitachi	EH3500AC11	185	2*	95	2*	110
Hitachi	EH3500AC-3	200	2*	105	2*	110
Komatsu	730E	203	2*	110	2*	110
Komatsu	730E-8	200	2*	115	2*	110
Terex	MT 3700	205	2*	110	CT	CT

40.00R57 Rigid Truck Usage Chart

For Standard Earthmover Service: <2.5 mile, < 30 mph

Manufacturer	Model	Payload	Front Minimum Load Rating	Front Minimum Inflation	Rear Minimum Load Rating	Rear Minimum Inflation
		Tons		Psi		Psi
Belaz	75302NA	242.5	2*	110	2*	110
Belaz	75310	265	CT	CT	CT	CT
Caterpillar	789D	200	2*	90	2*	90
Caterpillar	793D	240	2*	110	2*	115
Caterpillar	793F	247	NR	NR	NR	NR
Hitachi	EH3500AC-3	200	2*	90	2*	90
Hitachi	EH4000ACII	250	2*	105	2*	105
Hitachi	EH4000AC-3	250	2*	105	2*	105
Komatsu	730E-8	200	2*	95	2*	90
Komatsu	830E	244	2*	110	2*	115
Komatsu	830E-AC	244	2*	110	2*	115
Liebherr	T264	244	2*	110	2*	115
Terex	MT 3700	205	2*	90	2*	95
Terex	MT 4400	260	2*	115	2*	115

46/90R57 Rigid Truck Usage Chart

For Standard Earthmover Service: <2.5 mile, < 30 mph

Manufacturer	Model	Payload	Front Minimum Load Rating	Front Minimum Inflation	Rear Minimum Load Rating	Rear Minimum Inflation
		Tons		Psi		Psi
Belaz	75302NA	243	2*	100	2*	105
Belaz	75310	265	2*	110	2*	115
CAT	793F	250	2*	105	2*	105
Hitachi	EH4000AC-2	245	2*	105	2*	105
Hitachi	EH4000AC-3	250	2*	100	2*	100
Komatsu	830E-AC	244	2*	105	2*	110
Liebherr	T264	251	2*	110	2*	110
Terex	MT 3700	205	2*	85	2*	90
Terex	MT 4400	260	2*	110	2*	110
Terex	MT 4400AC	260	2*	110	2*	110

Pressure and ply recommendations based on normal quarry operations with standard equipment. For different applications, or modified equipment, please contact OTR Field Engineering for a specific recommendation. Tire damage or failure caused by improper load, ply, speed or inflation practices is not covered by the Titan Tire Warranty Policy.

CT - Contact Titan Technical services

NR - Not recommended

Load and Inflation Tables

50/80R57 Rigid Truck Usage Chart

For Standard Earthmover Service: <2.5 mile, < 30 mph

Manufacturer	Model	Payload	Front Minimum Load Rating	Front Minimum Inflation	Rear Minimum Load Rating	Rear Minimum Inflation
		Tons		Psi		Psi
Bucyrus	MT4400 AC	240	2*	90	2*	90
Caterpillar	793F	250	2*	90	2*	90
Hitachi	EH4500-2	282	2*	105	2*	100
Komatsu	860E-1K	280	2*	110	2*	110
Liebherr	T272	320	2*	105	2*	105

53/80R63 Rigid Truck Usage Chart

For Standard Earthmover Service: <2.5 mile, < 30 mph

Manufacturer	Model	Payload	Front Minimum Load Rating	Front Minimum Inflation	Rear Minimum Load Rating	Rear Minimum Inflation
		Tons		Psi		Psi
Caterpillar	MT5300AC	320	2*	110	2*	115
Hitachi	EH5000ACII	320	2*	105	2*	105
Hitachi	EH5000AC-3	326	2*	105	2*	105
Komatsu	930E-2	320	2*	110	2*	105
Komatsu	930E-3	320	2*	105	2*	105
Komatsu	930E-4	320	2*	105	2*	105
Komatsu	930E-4SE	320	2*	105	2*	110

56/80R63 Rigid Truck Usage Chart

For Standard Earthmover Service: <2.5 mile, < 30 mph

Manufacturer	Model	Payload	Front Minimum Load Rating	Front Minimum Inflation	Rear Minimum Load Rating	Rear Minimum Inflation
		Tons		Psi		Psi
Belaz	75600	350	2*	100	2*	105
Cat	795 AC	345	2*	105	2*	105
Komatsu	960E-1	360	2*	105	2*	105
Komatsu	960E-1K	360	2*	105	2*	105
Komatsu	960E-2	360	2*	105	2*	105
Komatsu	960E-2K	360	2*	105	2*	105
Liebherr	T282C	400	2*	110	2*	110
Liebherr	T284	400	2*	110	2*	110
Terex	MT 5500	360	2*	100	2*	100

Pressure and ply recommendations based on normal quarry operations with standard equipment. For different applications, or modified equipment, please contact OTR Field Engineering for a specific recommendation. Tire damage or failure caused by improper load, ply, speed or inflation practices is not covered by the Titan Tire Warranty Policy.

CT - Contact Titan Technical services

59/80R63 Rigid Truck Usage Chart

For Standard Earthmover Service: <2.5 mile, < 30 mph

Manufacturer	Model	Payload	Front Minimum Load Rating	Front Minimum Inflation	Rear Minimum Load Rating	Rear Minimum Inflation
		Tons		Psi		Psi
Belaz	75600	350	2*	95	2*	95
Belaz	75601	400	2*	105	2*	105
Belaz	75710	500	2*	105	2*	105
Belaz	75710	515	2*	110	2*	110
CAT	795F AC	345	2*	95	2*	100
Cat	797F	400	2*	110	2*	110
Liebherr	T282C	400	2*	105	2*	105
Liebherr	T284	400	2*	105	2*	105
Terex	MT 5500	360	2*	90	2*	90
Terex	MT 6300	400	2*	105	2*	105

Pressure and ply recommendations based on normal quarry operations with standard equipment. For different applications, or modified equipment, please contact OTR Field Engineering for a specific recommendation. Tire damage or failure caused by improper load, ply, speed or inflation practices is not covered by the Titan Tire Warranty Policy.

CT - Contact Titan Technical services

Load and Inflation Tables

17.5R25 Towed Scraper Usage Chart

For Standard Scraper Service: <2.5 mile, < 30 mph

Manufacturer	Model	Payload	Tires Per Axle	Tire Minimum Load Rating	Tire Minimum Inflation
		Cu. Yd.			Psi
Deere	1510DC	15	4	2*	70
Deere	1814DC	18	6	2*	55
Deere	2014DE	20	6	2*	65

20.5R25 Towed Scraper Usage Chart

For Standard Scraper Service: <2.5 mile, < 30 mph

Manufacturer	Model	Payload	Tires Per Axle	Tire Minimum Load Rating	Tire Minimum Inflation
		Cu. Yd.			Psi
Ashland	110TS2	11.3	2	2*	75
Ashland	110XL2	11.3	2	CT	CT
Ashland	130TS2	13.3	2	CT	CT
Ashland	220TS4	22	4	CT	CT
Ashland	2014CS	20	6	1*	45
Deere	1510DC	15	4	1*	50
Deere	1612DE	16	4	2*	60
Deere	1810DC	18	4	2*	60
Deere	1812DC	18	4	2*	60
Deere	1814DC	18	6	1*	40
Deere	2010DE	20	4	2*	75
Deere	2014DE	20	6	1*	45

23.5R25 Towed Scraper Usage Chart

For Standard Scraper Service: <2.5 mile, < 30 mph

Manufacturer	Model	Payload	Tires Per Axle	Tire Minimum Load Rating	Tire Minimum Inflation
		Cu. Yd.			Psi
Caterpillar	TS185	19	4	1*	50
Deere	2112DC	21.5	6	1*	40
Deere	2412DE	24	4	2*	70
K-Tec	1228	28	4	2*	70
K-Tec	1233	33	4	CT	CT
K-Tec	1236	36	4	CT	CT

Pressure and ply recommendations based on normal quarry operations with standard equipment. For different applications, or modified equipment, please contact OTR Field Engineering for a specific recommendation. Tire damage or failure caused by improper load, ply, speed or inflation practices is not covered by the Titan Tire Warranty Policy.

CT - Contact Titan Technical services

26.5R25 Towed Scraper Usage Chart

For Standard Scraper Service: <2.5 mile, < 30 mph

Manufacturer	Model	Payload	Tires Per Axle	Tire Minimum Load Rating	Tire Minimum Inflation
		Cu. Yd.			Psi
Caterpillar	TS185	19	4	1*	40
Caterpillar	TS225	23.5	4	1*	45
Deere	2112DC (1)	21.5	4	2*	65
Deere	2112DC (2)	21.5	4	1*	45
Deere	2412DE (1)	24	4	2*	75
Deere	2412DE (2)	24	4	1*	55
K-Tec	1233	33	4	2*	65

29.5R25 Towed Scraper Usage Chart

For Standard Scraper Service: <2.5 mile, < 30 mph

Manufacturer	Model	Payload	Tires Per Axle	Tire Minimum Load Rating	Tire Minimum Inflation
		Cu. Yd.			Psi
Ashland	155TS2	15.5	2	1*	50
Ashland	215TS2	21.5	2	2*	70
Caterpillar	TS180	18.8	2	2*	60
Deere	2010D E	20	2	2*	65

875/65R29 Towed Scraper Usage Chart

For Standard Scraper Service: <2.5 mile, < 30 mph

Manufacturer	Model	Payload	Tires Per Axle	Tire Minimum Load Rating	Tire Minimum Inflation
		Cu. Yd.			Psi
Caterpillar	TS180	18.8	2	2*	55
Caterpillar	TS220	23.5	2	2*	65
Deere	2412DE	24	2	CT	CT

23.5R25 Tractor Scraper Usage Chart

For Standard Scraper Service: <2.5 mile, < 30 mph

Manufacturer	Model	Payload	Front Minimum Load Rating	Front Minimum Inflation	Rear Minimum Load Rating	Rear Minimum Inflation
		Cu. Yd.		Psi		Psi
Caterpillar	613B	11	1*	50	1*	50
Caterpillar	613C	11	1*	50	1*	50
Caterpillar	613C II	11	1*	50	1*	55
Caterpillar	613G	11	2*	60	1*	55
Deere	762	11	1*	55	1*	55
Deere	762A	11	2*	60	1*	55
Deere	762B	11	2*	60	1*	55
Deere	762B II	14	2*	60	1*	55
Komatsu Dresser	412	11	1*	50	1*	55
Komatsu Dresser	412B	11	1*	55	1*	55

Pressure and ply recommendations based on normal quarry operations with standard equipment. For different applications, or modified equipment, please contact OTR Field Engineering for a specific recommendation. Tire damage or failure caused by improper load, ply, speed or inflation practices is not covered by the Titan Tire Warranty Policy.

Load and Inflation Tables

26.5R25 Tractor Scraper Usage Chart

For Standard Scraper Service: <2.5 mile, < 30 mph

Manufacturer	Model	Pa;yload	Front Minimum Load Rating	Front Minimum Inflation	Rear Minimum Load Rating	Rear Minimum Inflation
		Cu. Yd.		Psi		Psi
Caterpillar	611	15	2*	65	2*	65
Caterpillar	611C II	15	CT	CT	2*	65
Caterpillar	615	16	2*	70	2*	60
Caterpillar	615C	16	2*	70	2*	60
Caterpillar	615C II	17	2*	75	2*	70
Deere	860	15	2*	55	2*	60
Deere	860A Std	15	2*	60	2*	60
Deere	860A HD	15	2*	65	2*	60
Deere	862	16	2*	65	2*	65
Deere	862B	16	2*	65	2*	65
Fiat Allis	161	15	2*	60	2*	60

29.5R25 Tractor Scraper Usage Chart

For Standard Scraper Service: <2.5 mile, < 30 mph

Manufacturer	Model	Pa;yload	Front Minimum Load Rating	Front Minimum Inflation	Rear Minimum Load Rating	Rear Minimum Inflation
		Cu. Yd.		Psi		Psi
Caterpillar	611	15	1*	55	1*	50
Caterpillar	611C II	15	1*	55	1*	50
Caterpillar	615	16	1*	55	1*	50
Caterpillar	615C	16	1*	55	1*	50
Caterpillar	615C II	17	2*	60	1*	55
Deere	862 w/ Kress bowl	18	1*	55	1*	55
Deere	862 w/ Kress bowl	20	2*	60	2*	60
Deere	862B	16	1*	50	1*	50
Fiat Allis	161	15	1*	45	1*	45
Terex	TS14B	20	2*	65	2*	60
Terex	TS14C	20	2*	65	2*	60
Terex	TS14G	20	2*	70	2*	65

Pressure and ply recommendations based on normal quarry operations with standard equipment. For different applications, or modified equipment, please contact OTR Field Engineering for a specific recommendation. Tire damage or failure caused by improper load, ply, speed or inflation practices is not covered by the Titan Tire Warranty Policy.

CT - Contact Titan Technical services

Load and Inflation Tables

Off the Road Tire Loads - Use on Industrial Vehicles

	Ply Rating	Inflation Pressure psi (kPa)	Load in pounds (kg) at various Speeds						
			Stationary	Creep	2.5 mph (4 km/h)	5 mph (10 km/h)	10 mph (15 km/h)	12.5 mph (20 km/h)	15 mph (25 km/h)
14.00-24/25	24	123 (850)	33500 (15200)	27300 (12400)	24000 (10900)	20900 (9500)	19400 (8800)	18500 (8400)	17900 (8100)
	28	134 (925)	35300 (16000)	28700 (13000)	25400 (11500)	22000 (10000)	20500 (9300)	19400 (8800)	18700 (8500)
16.00-25	32	127 (875)	44100 (20000)	35900 (16300)	31700 (14400)	27600 (12500)	25600 (11600)	24300 (11000)	23400 (10600)
18.00-25	40	138 (950)	60000 (27200)	48700 (22100)	43200 (19600)	37500 (17000)	34800 (15800)	33100 (15000)	32000 (14500)
18.00-33	40	138 (950)	70500 (32000)	57300 (26000)	50700 (23000)	44000 (20000)	41000 (18600)	38800 (17600)	37500 (17000)
21.00-25	40	120 (825)	72800 (33000)	59100 (26800)	52200 (23700)	45400 (20600)	42300 (19200)	39900 (18100)	38600 (17500)
21.00-35	36	109 (750)	81100 (36800)	65900 (29900)	58300 (26400)	50700 (2300)	47200 (21400)	44600 (20200)	43100 (19600)
	42	123 (850)	85800 (38900)	69700 (31600)	61500 (27900)	53600 (24300)	49800 (22600)	47200 (21400)	45600 (20700)

Industrial Vehicle for use on Smooth Floors and Runways Only

	Ply Rating	Inflation Pressure psi (kPa)	Load in pounds (kg) at various Speeds						
			Stationary	Creep	2.5 mph (4 km/h)	5 mph (10 km/h)	10 mph (15 km/h)	12.5 mph (20 km/h)	15 mph (25 km/h)
14.00-24/25	24	145 (1000)	36700 (16700)	32600 (14800)	29600 (13400)	27600 (12500)	26500 (12000)	25800 (11700)	25600 (11600)
	28	145 (1000)	36700 (16700)	32600 (14800)	29600 (13400)	27600 (12500)	26500 (12000)	25800 (11700)	25600 (11600)
16.00-25	32	145 (1000)	49700 (22500)	44200 (20000)	40000 (18100)	37300 (16900)	35900 (16300)	35100 (15900)	34500 (15600)
18.00-25	40	145 (1000)	63500 (28800)	56500 (25600)	51200 (23200)	47600 (21600)	45900 (20800)	44800 (20300)	44100 (20000)
18.00-33	40	145 (1000)	73400 (33000)	65300 (29600)	59200 (26800)	55100 (25000)	53100 (24100)	51800 (23500)	50900 (23100)
21.00-25	40	145 (1000)	81800 (37100)	72600 (33000)	65800 (29900)	61300 (27800)	59100 (26800)	57800 (26200)	56900 (25800)
21.00-35	36	131 (900)	91300 (41400)	81100 (36800)	73500 (33400)	68400 (31100)	65900 (29900)	64400 (29200)	63400 (28800)
	42	145 (1000)	96300 (43700)	85800 (38900)	77700 (35200)	72300 (32800)	69700 (31600)	68100 (30900)	67000 (30400)

IMPORTANT: Loads shown in the above table are for the tire only. The rim manufacturer must be consulted to determine the suitability of the rim/wheel for the intended service. Industrial vehicles consist of vehicles such as counterbalanced lift trucks, container handlers, straddle carriers, aircraft tow tractors, pavers, mobile crushers, log stackers and rough terrain fork lifts.

Creep is defined as movement at very slow speed, not over 200' (60 m) in 30 minutes. During creep motion loads on tires are very high. Consideration must be given to the type of surface over which the equipment is travelling.

Smooth floors and runways are defined as paved or protected surfaces which are free of undulations, obstructions or discontinuities.

Load and Inflation Tables

Loads for E-7 Tires in Paving Service

14.00-20DT											
Inflation	kPA psi	75 11	100 15	125 18	150 22	175 25	200 29	240 35	250 36	275 40	300 44
Load (10 km/h 5 mph)	kg lbs.	2060 4540	2500 5520	2800 6150	3150 6950	3450 7600	3750 8250	4125 9100	4250 9350	4500 9900	4750 10500
Ply rating		10									

Loads at Speeds other than 10 km/h (5 mph)

65 km/h (40 mph)	kg lbs.	1195 2634	1450 3195	1624 3580	1827 4028	2001 4411	2175 4795	2393 5274	2465 5434	2610 5754	2755 6074
50 km/h (30 mph)	kg lbs.	1400 3090	1700 3750	1900 4190	2140 4720	2350 5180	2550 5620	2810 6190	2890 6370	3060 6750	3230 7120
25 km/h (15 mph)	kg lbs.	1650 3640	2000 4410	2240 4940	2520 5560	2760 6080	3000 6610	3300 7280	3400 7500	3600 7940	3800 8380
20 km/h (12.5 mph)	kg lbs.	1730 3810	2100 4630	2350 5180	2650 5840	2900 6390	3150 6940	3470 7650	3570 7870	3780 8330	3990 8800
15 km/h (10 mph)	kg lbs.	1790 3950	2180 4810	2440 5380	2740 6040	3000 6610	3260 7190	3590 7910	3700 8160	3920 8640	4130 9100
10 km/h (5 mph)	kg lbs.	2060 4540	2500 5520	2800 6150	3150 6950	3450 7600	3750 8250	4125 9100	4250 9350	4500 9900	4750 10500
4 km/h (2.5 mph)	kg lbs.	2370 5220	2880 6350	3220 7100	3620 7980	3970 8750	4310 9500	4740 10450	4890 10780	5180 11420	5460 12040
Creep	kg lbs.	2680 5910	3250 7160	3640 8020	4100 9040	4490 9900	4880 10760	5360 11820	5530 12190	5850 12900	6180 13620
Stationary	kg lbs.	3300 7280	4000 8820	4480 9880	5040 11110	5520 12170	6000 13230	6600 14550	6800 14990	7200 15870	7600 16750

16.00-24DT

Inflation	kPA psi	75 11	100 15	125 18	150 22	175 25	200 29	240 35	250 36	275 40	300 44
Load (10 km/h 5 mph)	kg lbs.	3750 8250	4500 9900	5000 11000	5600 12300	6150 13600	6700 14800	7500 16500	7500 16500	8000 17600	8500 18700
Ply rating		12									

Loads at Speeds other than 10 km/h (5 mph)

65 km/h (40 mph)	kg lbs.	2180 4810	2610 5750	2900 6390	3250 7160	3570 7870	3890 8580	4350 9590	4350 9590	4640 10230	4930 10870
50 km/h (30 mph)	kg lbs.	2550 5620	3060 6750	3400 7500	3810 8400	4180 9220	4560 10050	5100 11240	5100 11240	5440 11990	5780 12740
25 km/h (15 mph)	kg lbs.	3000 6610	3600 7940	4000 8820	4480 9880	4920 10850	5360 11820	6000 13230	6000 13230	6400 14110	6800 14990
20 km/h (12.5 mph)	kg lbs.	3150 6940	3780 8330	4200 9260	4700 10360	5170 11400	5630 12410	6300 13890	6300 13890	6720 14810	7140 15740
15 km/h (10 mph)	kg lbs.	3260 7190	3920 8640	4350 9590	4870 10740	5350 11790	5830 12850	6530 14400	6530 14400	6960 15340	7400 16310
4 km/h (2.5 mph)	kg lbs.	4310 9500	5180 11420	5750 12680	6440 14200	7070 15590	7700 16980	8630 19030	8630 19030	9200 20280	9780 21560
Creep	kg lbs.	4880 10760	5850 12900	6500 14330	7280 16050	8000 17640	8710 19200	9750 21490	9750 21490	10400 22930	11050 24360
Stationary	kg lbs.	6000 13230	7200 15870	8000 17640	8960 19750	9840 21690	10720 23630	12000 26460	12000 26460	12800 28220	13600 29980

Ply ratings for paving tires are based on speed of 10 km/h (5 mph).

Load and Inflation Tables

Loads for E-7 Tires on Pavers continued

18.00-25DT																			
Inflation	kPA psi	75 11	100 15	125 18	150 22	175 25	200 29	240 35	250 36	275 40	300 44	325 47	350 51	375 54	400 58	425 62	450 65	475 69	500 73
Load (10 km/h 5 mph)	kg lbs.	3875 8550	4625 10200	5300 11700	5800 12800	6300 13900	6900 15200	775 17100	7750 17100	8250 18200	8750 19300	9250 20400	9500 20900	10000 22000	10300 22700	10600 23400	11200 24700	11500 25400	11800 26000
Ply rating		16														20			

Loads at Speeds other than 10 km/h (5 mph)																			
65 km/h (40 mph)	kg lbs.	2250 4960	2610 5750	2990 6590	3360 7410	3650 8050	4000 8820	4350 9590	4500 9920	4790 10560	5080 11200	5220 11510	5510 12150	5800 12790	5970 13160	6150 13560	6320 13930	6670 14700	6840 15080
50 km/h (30 mph)	kg lbs.	2640 5820	3060 6750	3500 7720	3940 8690	4280 9440	4690 10340	5100 11240	5270 11620	5610 12370	5950 13120	6120 13490	6460 14240	6800 14990	7000 15430	7210 15900	7410 16340	7820 17240	8020 17680
25 km/h (15 mph)	kg lbs.	3100 6830	3600 7940	4120 9080	4640 10230	5040 11110	5520 12170	6000 13230	6200 13670	6600 14550	7000 15430	7200 15870	7600 16750	8000 17640	8240 18170	8480 18690	8720 19220	9200 20280	9440 20810
20 km/h (12.5 mph)	kg lbs.	3260 7190	3780 8330	4330 9550	4870 10740	5290 11660	5800 12790	6300 13890	6510 14350	6930 15280	7350 16200	7560 16670	7980 17590	8400 18520	8650 19070	8900 19620	9160 20190	9660 21300	9910 21850
15 km/h (10 mph)	kg lbs.	3370 7430	3920 8640	4480 9880	5050 11130	5480 12080	6000 13230	6530 14400	6740 14860	7180 15830	7610 16780	7830 17260	8270 18230	8700 19180	8960 19750	9220 20330	9480 20900	10010 22070	10270 22640
10 km/h (5 mph)	kg lbs.	3875 8550	4625 10200	5300 11700	5800 12800	6300 13900	6900 15200	775 17100	7750 17100	8250 18200	8750 19300	9250 20400	9500 20900	10000 22000	10300 22700	10600 23400	11200 24700	11500 25400	11800 26000
4 km/h (2.5 mph)	kg lbs.	4460 9830	5180 11420	5920 13050	6670 14700	7240 15960	7930 17480	8630 19030	8910 19640	9490 20920	10060 22180	10350 22820	10930 24100	11500 25350	11840 26100	12190 26870	12530 27620	13220 29140	13570 29920
Creep	kg lbs.	5040 11110	5850 12900	6700 14770	7540 16620	8190 18060	8970 19780	9750 21490	10080 22220	10730 23600	11380 25090	11700 25790	12350 27230	13000 28660	13390 29520	13780 30380	14170 31240	14950 32960	15340 33820
Stationary	kg lbs.	6200 13670	7200 15870	8240 18170	9280 20460	10080 22220	11040 24340	12000 26460	12400 27340	13200 29100	14000 30860	14400 31750	15200 33510	16000 35270	16480 36330	16960 37390	17440 38450	18400 40560	18880 41620

21.00-25DT																			
Inflation	kPA psi	150 22	175 25	200 29	240 35	250 36	275 40	300 44	325 47	350 51	375 54	400 58	425 62	450 65	475 69	500 73	525 76	550 80	575 83
Load (10 km/h 5 mph)	kg lbs.	7500 16530	8250 18190	9000 19840	10000 22050	10000 22050	10600 23370	11200 24690	11800 26010	12500 27560	12850 28330	13200 29100	14000 30860	14500 31970	14500 31970	15000 33100	15500 34200	16000 35300	16500 36400
Ply rating		28																	

Loads at Speeds other than 10 km/h (5 mph)																			
65 km/h (40 mph)	kg lbs.	4350 9590	4790 10560	5220 11510	5800 12790	5800 12790	6150 13560	6500 14330	6840 15080	7250 15980	7450 16420	7660 16890	8120 17900	8410 18540	8410 18540	8700 1980	8990 19820	9280 20460	9570 21100
50 km/h (30 mph)	kg lbs.	5100 11240	5610 12370	6120 13490	6800 14990	6800 14990	7210 15900	7620 16800	8020 17680	8500 18740	8740 19270	8980 19800	9520 20990	9860 21740	9860 21740	10200 22490	10540 23240	10880 23990	11220 24740
25 km/h (15 mph)	kg lbs.	6000 13230	6600 14550	7200 15870	8000 17640	8000 17640	8480 18690	8960 19750	9440 20810	10000 22050	10280 22660	10560 23280	11200 24690	11600 25570	11600 25570	12000 26460	12400 27340	12800 28220	13200 29100
20 km/h (12.5 mph)	kg lbs.	6300 13890	6930 15280	7560 16670	8400 18520	8400 18520	8900 19620	9410 20750	9910 21850	10500 23150	10790 23790	11090 24450	11760 25930	12180 26850	12180 26850	12600 27780	13020 28700	13440 29630	13860 30560
15 km/h (10 mph)	kg lbs.	6530 14400	7180 15830	7830 17260	8700 19180	8700 19180	9220 20330	9740 21470	10270 22640	10880 23990	11180 24650	11480 25310	12180 26850	12620 27820	12620 27820	13050 28770	13490 29740	13920 30690	14360 31660
10 km/h (5 mph)	kg lbs.	7500 16530	8250 18190	9000 19840	10000 22050	10000 22050	10600 23370	11200 24690	11800 26010	12500 27560	12850 28330	13200 29100	14000 30860	14500 31970	14500 31970	15000 33100	15500 34200	16000 35300	16500 36400
4 km/h (2.5 mph)	kg lbs.	8630 19030	9490 20920	10350 22820	11500 25350	11500 25350	12190 26870	12880 28400	13570 29920	14370 31680	14780 32580	15180 33470	16100 35490	16680 36770	16680 36770	17250 38030	17830 39310	18400 40560	18980 41840
Creep	kg lbs.	9750 21490	10730 23660	11700 25790	13000 28660	13000 28660	13780 30380	14560 32100	15340 33820	16250 35820	16710 36840	17160 37830	18200 40120	18850 41560	18850 41560	19500 42990	20150 44420	20800 45860	21450 47290
Stationary	kg lbs.	12000 26460	13200 29100	14400 31750	16000 35270	16000 35270	16960 37390	17920 39510	18880 41620	20000 44090	20560 45330	21120 46560	22400 49380	23200 51550	23200 51550	24000 52910	24800 54670	25600 56440	26400 58200

Ply ratings for paving tires are based on speed of 10 km/h (5 mph).

Load and Inflation Tables

High Flotation Tires Used In Agricultural, Logging And Off-The-Road Service

Tire Size	Speed mph	TIRE LOAD LIMITS (LBS.) AT VARIOUS COLD INFLATION PRESSURES (PSI)																
		10	15	20	25	30	35	40	45	50	55	60	65	70	75	80	85	90
66x44.00-25NHS	30	6,000	7600 (6)	9,100	10,200	11,400	12,800	13600 (16)	14,300	15700 (20)	16,500	17,100	18200 (26)					
	20	6,700	8,500	10,200	11,400	12,800	14,300	15,200	16,000	17,600	18,500	19,200	20,400					
	10	7,900	10,000	12,000	13,500	15,000	16,900	18,000	18,900	20,700	21,800	22,600	24,000					
	5	9,500	12,000	14,400	16,100	18,000	20,200	21,500	22,600	24,800	26,100	27,000	28,800					
	Creep	12,000	15,200	18,200	20,400	22,800	25,600	27,200	28,600	31,400	33,000	34,200	36,400					
	Stationary	15,900	20,100	24,100	27,000	30,200	33,900	36,000	37,900	41,600	43,700	45,300	48,200					
68x50.00-32NHS	30	5,840	7,400	8,800	9,900 (10)	11,000 (12)	12300 (16)	13,200	14300 (20)	----	----	----	----					
	20	6,550	8,300	9,850	11,100	12,300	13,800	14,800	16,000	----	----	----	----					
	10	7,700	9,750	11,600	13,100	14,500	16,200	17,400	18,900	----	----	----	----					
	5	9,250	11,700	13,900	15,600	17,400	19,400	20,900	22,600	----	----	----	----					
	Creep	11,700	14,800	17,600	19,800	22,000	24,600	26,400	28,600	----	----	----	----					
	Stationary	15,500	19,600	23,300	26,200	29,200	32,600	35,000	37,900	----	----	----	----					
66x43.00-25NHS	30	5,840	7,400	8,800	9,900 (10)	11000 (12)	12300 (14)	13200 (16)	13900	14800 (20)	15,700	16,500	17600 (26)					
	20	6,550	8,300	9,850	11,100	12,300	13,800	14,800	15,600	16,600	17,600	18,500	19,700					
	10	7,700	9,750	11,600	13,100	14,500	16,200	17,400	18,400	19,500	20,700	21,800	23,200					
	5	9,250	11,700	13,900	15,600	17,400	19,400	20,900	21,960	23,400	24,800	26,100	27,800					
	Creep	11,700	14,800	17,600	19,800	22,000	24,600	26,400	27,800	29,600	31,400	33,000	35,200					
	Stationary	15,500	19,600	23,300	26,200	29,200	32,600	35,000	36,800	39,200	41,600	43,700	46,600					
66x43.00-26NHS	30	5,840	7,400	8,800	9,900	11,000	12000 (14)	13200 (16)	13,900	14800 (20)	15,700	16,500	17100 (26)					
	20	6,550	8,300	9,850	11,100	12,300	13,400	14,800	15,600	16,600	17,600	18,500	19,200					
	10	7,700	9,750	11,600	13,100	14,500	15,800	17,400	18,300	19,500	20,700	21,800	22,600					
	5	9,250	11,700	13,900	15,600	17,400	19,000	20,900	22,000	23,400	24,800	26,100	27,000					
	Creep	11,700	14,800	17,600	19,800	22,000	24,000	26,400	27,800	29,600	31,400	33,000	34,200					
	Stationary	15,500	19,600	23,300	26,200	29,200	31,800	35,000	36,800	39,200	41,600	43,700	45,300					
67x34.00-25NHS	30	5,840	7,400	8,800	10,200	11400 (10)	12,300	13200 (14)	14,300	15,200	16100 (20)	----	----					
	20	6,550	8,300	9,850	11,400	12,800	13,800	14,800	16,000	17,000	18,000	----	----					
	10	7,700	9,750	11,600	13,500	15,000	16,200	17,400	18,900	20,100	21,300	----	----					
	5	9,250	11,700	13,900	16,100	18,000	19,400	20,900	22,600	24,000	25,400	----	----					
	Creep	11,700	14,800	17,600	20,400	22,800	24,600	26,400	28,600	30,400	32,200	----	----					
	Stationary	15,500	19,600	23,300	27,000	30,200	32,600	35,000	37,900	40,300	42,700	----	----					
67x34.00-26NHS	30	5,840	7,400	8,800	9,900	11,000	12,000	13200 (14)	13,900	14,800	15700 (20)	----	----					
	20	6,550	8,300	9,850	11,100	12,300	13,400	14,800	15,600	16,600	17,600	----	----					
	10	7,700	9,750	11,600	13,100	14,500	15,800	17,400	18,300	19,500	20,700	----	----					
	5	9,250	11,700	13,900	15,600	17,400	19,000	20,900	22,000	23,400	24,800	----	----					
	Creep	11,700	14,800	17,600	19,800	22,000	24,000	26,400	27,800	29,600	31,400	----	----					
	Stationary	15,500	19,600	23,300	26,200	29,200	31,800	35,000	36,800	39,200	41,600	----	----					
DH73x44.00-32 VA73x43.00-32	30	6,800	8,550	10,200	11,700	12,800 (12)	14,300	15200 (16)	16,500	17600 (20)	----	----	----					
	20	7,600	9,600	11,400	13,100	14,300	16,000	17,000	18,500	19,700	----	----	----					
	10	9,000	11,300	13,500	15,400	16,900	18,900	20,100	21,800	23,200	----	----	----					
	5	10,700	13,500	16,100	18,500	20,200	22,600	24,000	26,100	27,800	----	----	----					
	Creep	13,600	17,100	20,400	23,400	25,600	28,600	30,400	33,000	35,200	----	----	----					
	Stationary	18,000	22,700	27,000	31,000	33,900	37,900	40,300	43,700	46,600	----	----	----					
DH73x50.00-32	30	6,950	8,800	10,500	12,000	13,200	14800 (16)	15,700	17100 (20)	----	----	----	----					
	20	7,800	9,850	11,800	13,400	14,800	16,600	17,600	19,200	----	----	----	----					
	10	9,150	11,600	13,900	15,800	17,400	19,500	20,700	22,600	----	----	----	----					
	5	11,000	13,900	16,600	19,000	20,900	23,400	24,800	27,000	----	----	----	----					
	Creep	13,900	17,600	21,000	24,000	26,400	29,600	31,400	34,200	----	----	----	----					
	Stationary	18,400	23,300	27,800	31,800	35,000	39,200	41,600	45,300	----	----	----	----					

- NOTES:
- The small index numbers denote ply rating for which accompanying loads and inflations are maximum.
 - For variable loading operations where loads increase or decrease, the load per tire when the vehicle is empty must be less than 40% of the load on the tire when the vehicle is fully loaded. Maximum load may not be carried for more than one mile before unloading operation starts. Loading or unloading must be completed within one mile.
 - For operations at other speeds with no change in inflation pressure, the loads in the above table may be changed as follows:
 - Creep Speed is a travel rate of not over 200 feet in a 30 minute period.

MAXIMUM SPEED (mph)	% CHANGE IN LOADS
20	+12
10	+32
5	+58
*Creep	+100
Stationary	+165

Load and Inflation Tables

Radial Ply Terra

High Flotation Tires Used in Agricultural, Logging and Off-the-Road Service

TIRES USED AS SINGLES WITH NO SUSTAINED HIGH TORQUE

MAX SPEED - 30 MPH	TIRE LOAD LIMITS (LBS.) AT VARIOUS COLD INFLATION PRESSURES (PSI)															
	TIRE SIZE	6	9	12	15	17	20	23	26	29	32	35	38	41	44	46
	1000/50R25	5360	6400	7400	8550	9650 (159)	10700	11700 (166)	12300	13200	13600	13900 (172)	14800	15200	16100	16500 (178)
	1050/50R25	5840	6950	8050	9350	10500 (162)	11700	12800 (169)	13600	14300	14800	15200 (175)	16100	16500 (178)	---	---
	1050/50R32	6400	7600	8800	10200	11400 (165)	12800	13900 (172)	14800	15700	16100	16500 (178)	---	---	---	---
	LSW1100/45R46	10200*	12300*	14300	16500	18200 (181)	20400	22700 (189)	24000	24700	26000	26800 (195)	----	----	----	----
	LSW1100/45R46 (Muck Master)	8800*	10500*	12300	13900	15700 (176)	17600	19300 (183)	20400	21500	22000	23400 (190)	----	----	----	----
	1250/40R25	6150	7400	8800	9900	11000 (164)	12300	13600 (171)	14300	15200 (175)	15700	16500 (178)	17100	17600 (180)	---	---
	1250/35R32	6000	7400	8550	9650	11000 (164)	12000	13200 (170)	14300	14800	15700	16100 (177)	---	---	---	---
	1250/50R32	8550	10200	11700	13600	15200 (175)	17100	18700 (182)	19800	20400 (185)	21500	22000 (188)	---	---	---	---
	1250/35R42	6800	8250	9650	11000	12300 (168)	13600	15200 (175)	16100	16500 (178)	17600	18200 (181)	---	---	---	---
	1250/35R46	7150	8550	9900	11400	12800 (169)	14300	15700 (176)	16500	17600 (180)	18200	18700 (182)	19800	20400 (185)	21500	22000 (188)
	LSW1250/40R46	9650*	11700*	13600	15200	17100 (179)	19300	20900 (186)	22700	23400	24700	25400 (193)	----	----	----	----
	LSW1400/30R46	10500*	12300*	14800	16500	18700 (182)	20900	22700 (189)	24000	25400	26800	27600 (196)	----	----	----	----

- NOTES:
1. For loads at other conditions see notes 1, 2 and 3 on previous page.
 2. The number in parentheses is tire's load index.
 3. The loads with an asterisk are for calculation of dual loads only.

Diagonal (Bias) Ply Tires Used for Skid-Steer/Mini-Loader Service

MAX SPEED - 5 MPH	TIRE LOAD LIMITS (LBS.) AT VARIOUS COLD INFLATION PRESSURES (PSI)													
	TIRE SIZE	20	25	30	35	40	45	50	55	60	65	70	75	80
	10-16.5 NHS	---	---	2760 (4)	3020	3260	3500 (5)	3720	3930	4140 (8)	---	---	---	---
	12-16.5 NHS	---	---	3560	3900	4220 (6)	4520	4810 (8)	5080	5350	5600 (10)	5850	6090	6330 (12)
	14-17.5 NHS	---	---	4820 (6)	5270	5700 (8)	6110	6490	6870 (10)	---	---	---	---	---
	15-19.5 NHS	---	---	6130 (6)	6710	7250 (8)	7770	8260 (10)	8740	9190 (12)	9360	10060 (14)	10470	10880 (16)
	31x15.50-15 NHS	2700 (4)	3050	3395 (6)	3695	4015	4360 (8)	---	---	---	---	---	---	---

- NOTES:
1. Number in parentheses denote ply rating or load range for which loads and inflations are maximum..
 2. For 10 MPH service, the above loads must be reduced 21% at the same pressures.

Load and Inflation Tables

Diagonal (Bias) Ply Log Skidder Drive Wheel Tires Used in Logging or Forestry Service (other than on cable or grapple skidders) Tires Used as Singles

MAX SPEED 20 MPH (30 KM/H)		TIRE LOAD LIMITS (LBS.) AT VARIOUS COLD INFLATION PRESSURES					TIRE TYPE NOMENCLATURE	
TIRE SIZE	psi kPa	20 140	25 170	30 210	35 240	40 280	CODE NO.	TIRE TYPE
16.9-30	lbs. kg	4400 2000	5080 2300	5680 (10) 2575 (10) 141	6150 2800	6600 (14) 3000 (14) 148	LS-2	INTERMEDIATE TREAD
18.4-26	lbs. kg	4940 2240	5680 (10) 2575 (10) 141	6400 (12) 2900 (12) 145	---	---	LS-3	DEEP TREAD
18.4-34	lbs. kg	5680 2575	6400 (10) 2900 (10) 145	---	---	---		
23.1-26	lbs. kg	7150 (10) 3250 (10) 149	8250 3750	9100 (14) 4125 (14) 157	9900 (16) 4500 (16) 160	10700 (20) 4875 (20) 163		
24.5-32	lbs. kg	8800 4000	9900 (12) 4500 (12) 160	11000 (16) 5000 (16) 164	12000 (18) 5450 (18) 167	---		
28L-26	lbs. kg	8250 (12) 3750 (12) 154	9350 (14) 4250 (14) 158	10500 (16) 4750 (16) 162	11400 (20) 5150 (20) 165	---		
30.5L-32	lbs. kg	10500 (12) 4750 (12) 162	11700 (16) 5300 (16) 166	13200 (20) 6000 (20) 170	14300 6500	15700 (26) 7100 (26) 176		
DH35.5L-32	lbs. kg	13900 (16) 6300 (16) 172	16100 (20) 7300 (20) 177	17600 8000	19300 (26) 8750 (26) 183	---		

- NOTES:
- Figures in parentheses denote ply rating or load range for which bold face loads and inflations are maximum. Numbers after ply ratings are Load Index numbers.
 - For shipping purposes, tire inflation pressure may be increased to 30 psi (210 kPa). Inflation pressure must be adjusted to correct operating pressure before skidder is removed from carrier. Consult tire manufacturer for minimum tire shipping pressure.
 - "Tire Load Limit" for log skidders is defined as the maximum load for an individual tire due to the total radial forces imposed on the tire DURING OPERATION. This maximum load includes total vehicle weight with accessories and weight transfer. For grapple and cable skidders, refer to the table below.
 - For load and carry type of logging operations such as loaders equipped with log forks and feller-bunchers, with maximum speed of 5 mph (10 km/h), above tire load limits may be increased 50% with 5 psi (35 kPa) increase in inflation pressure. Maximum length of carry is 500 feet (150 m).
 - When used as duals, tire loads must be reduced. Multiply figures in table by .88.
 - Consult rim and wheel manufacturer for rims for this type of service.
 - For transport service and operations that do not require sustained high torque, the following load limits apply:

MAX SPEED	% CHANGE IN LOADS	CHANGE IN INFL. PRESSURE
STATIONARY	+170	+5 PSI (30 KPA)
10 MPH (15 KM/H)	+20	NONE
15 MPH (25 KM/H)	+15	NONE
20 MPH (30 KM/H)	NONE	NONE
25 MPH (40 KM/H)	-10	NONE

Diagonal (Bias) Ply Log Skidder Drive Wheel Tires Used on Cable or Grapple Skidders Tires Used as Singles

MAX SPEED 5 MPH (10 KM/H)		TIRE LOAD LIMITS (LBS.) AT VARIOUS COLD INFLATION PRESSURES				
TIRE SIZE	psi kPa	25 170	30 210	35 240	40 *275/280	45 310
18.4-26	lbs. kg	6900 3120	7950 (10) 3600 (10)	8950 (12) 4060 (12)	---	---
18.4-34	lbs. kg	7950 3600	8950 (10) 4060 (10)	---	---	---
23.1-26	lbs. kg	10000 (10) 4540 (10)	11600 5260	12700 (14) 5760 (14)	13900 (16) 6300 (16)	15200 (20) 6900 (20)
24.5-32	lbs. kg	12300 5580	13900 (12) 6300 (12)	15400 (16) 7000 (16)	16800 (18) 7600 (18)	---
Low Section Height						
28L-26	lbs. kg	11600 (12) 5260 (12)	13100 (14) 5940 (14)	14700 (16) 6650 (16)	16000 (20) 10000 (20)	---
30.5L-32	lbs. kg	14700 (12) 6650 (12)	16400 (16) 7450 (16)	18500 (20) 8400 (20)	20000 9000	22000 (26) 10000 (26)
DH35.5L-32	lbs. kg	19500 (16) 8850 (16)	22500 (20) 10200 (20)	24650 11200	27000 (26) 12150 (26)	---

- NOTES:
- Figures in parentheses denote ply rating or load range for which bold face loads and inflations are maximum.
 - For shipping purposes, tire inflation pressure may be increased to 30 psi (210 kPa). Inflation pressure must be adjusted to correct operating pressure before skidder is removed from carrier. Consult tire manufacturer for minimum tire shipping pressure.
 - "Tire Load Limit" for log skidders is defined as the maximum load for an individual tire due to the total radial forces imposed on the tire DURING OPERATION. This maximum load includes total vehicle weight with accessories, plus load increases due to log winching or grappling loads and weight transfer.
 - The table above applies only to log skidder tires used on cable or grapple skidders with a maximum speed of 5 mph (10 km/h). For use on other types of logging or forestry equipment or at speeds greater than 5 mph (10 km/h) refer to the table at the top of this page.
 - When used as duals, tire loads must be reduced. Multiply figures in table by .88.
 - Consult rim and wheel manufacturer for rims for this type of service.

Load and Inflation Tables

Material Handling Loads

Size	Service Condition Application Speed			Counterbalanced Lift Truck		Industrial Vehicle Loads				
	Ply Rating	Catalog Number	PSI (kPa)	Front/Drive	Rear/Steer	Smooth Floor Only		Other Than Smooth Floor		
				up to 10 mph (15 km/h & under) lbs. (kg)	up to 15 mph (25 km/h & under) lbs. (kg)	5 mph (10 km/h) lbs. (kg)	10 mph (15 km/h) lbs. (kg)	5 mph (10 km/h) lbs. (kg)	10 mph (15 km/h) lbs. (kg)	
Titan T40										
32x12-15 NHS	20	44P226	145 (1000)	13,400 (6,080)	10,200 (4,625)	10,200 (4,625)	8,050 (3,650)	9,150 (4,150)	7,250 (3,290)	
35x15-15 NHS	24	44P376	150 (1030)	17,950 (8,140)	13,655 (6,195)	13,655 (6,195)	10,790 (4,895)	12,305 (5,580)	9,695 (4,400)	
35x15-15 NHS	28	44P377	150 (1030)	17,950 (8,140)	13,655 (6,195)	13,655 (6,195)	10,790 (4,895)	12,305 (5,580)	9,695 (4,400)	
Titan T44										
44x18-20 NHS	32	44T3K1	150 (1030)	27,300 (12,385)	20,700 (9,930)	20,700 (9,930)	16,400 (7,440)	18,700 (8,480)	14,700 (6,670)	
42x21-22 NHS	32	44T3J5	145 (1000)	33,300 (15,105)	25,300 (11,475)	25,300 (11,475)	20,000 (9,070)	22,800 (10,340)	18,000 (8,165)	
Titan PWT										
7.00-12 NHS	12	44P212	125 (860)	5,995 (2,720)	4,555 (2,065)	4,555 (2,065)	3,595 (1,630)	4,100 (1,860)	3,235 (1,465)	
7.50-16 NHS	12	44P2K8	115 (790)	8,015 (3,635)	6,090 (2,760)	6,090 (2,760)	4,810 (2,180)	5,485 (2,490)	4,330 (1,965)	
8.25-15 NHS	12	44P231	105 (720)	8,680 (3,935)	6,595 (2,990)	6,595 (2,990)	5,210 (2,365)	5,935 (2,690)	4,685 (2,125)	
8.25-15 NHS	14	44P2D5	120 (830)	9,385 (4,255)	7,135 (3,235)	7,135 (3,235)	5,630 (2,555)	6,420 (2,910)	5,070 (2,300)	
250-15 NHS	16	4492H1	135 (930)	9,450 (4,285)	7,200 (3,265)	7,200 (3,265)	5,680 (2,575)	6,450 (2,925)	5,100 (2,315)	
250-15 NHS	18	44P2H2	150 (1030)	10,100 (4,580)	7,650 (3,470)	7,650 (3,470)	6,050 (2,745)	6,900 (3,130)	5,440 (2,470)	
28x12-15 NHS	20	44P2G2	150 (1030)	10,800 (4,900)	8,200 (3,720)	8,200 (3,720)	6,500 (2,950)	7,400 (3,355)	5,820 (2,640)	
28x9-15 NHS	12	44P2B5	120 (830)	6,880 (3,120)	5,230 (2,370)	5,230 (2,370)	4,125 (1,870)	4,705 (2,135)	3,715 (1,685)	
28x9-15 NHS	14	44P2D3	140 (970)	7,530 (3,415)	5,720 (2,595)	5,720 (2,595)	4,515 (2,050)	5,150 (2,335)	4,065 (1,845)	
29x8-15 NHS	12	44P216	125 (860)	6,870 (3,115)	5,220 (2,370)	5,220 (2,370)	4,120 (1,870)	4,700 (2,130)	3,710 (1,685)	
32x15-15 NHS	24	44P3G7	150 (1030)	15,900 (7,210)	12,100 (5,490)	12,100 (5,490)	9,550 (4,330)	10,900 (4,945)	8,600 (3,900)	
36x11-15 NHS	16	44P2F9	115 (790)	12,290 (5,575)	9,340 (4,235)	9,340 (4,235)	7,375 (3,345)	8,405 (3,815)	6,635 (3,010)	
36x11-15 NHS	24	44P6F9	145 (1000)	14,100 (6,395)	10,700 (4,855)	10,700 (4,855)	8,450 (3,835)	9,650 (4,375)	7,600 (3,445)	
5.70/5.00-8 NHS	10	4542A1	150 (1030)	2,790 (1,265)	2,120 (960)	2,120 (960)	1,675 (760)	1,905 (865)	1,505 (685)	
6.90/6.00-9 NHS	10	454204	125 (860)	3,715 (1,685)	2,820 (1,280)	2,820 (1,280)	2,230 (1,010)	2,540 (1,150)	2,000 (905)	
6.50-10 NHS	10	454263	115 (790)	4,225 (1,915)	3,210 (1,455)	3,210 (1,455)	2,535 (1,150)	2,890 (1,310)	2,280 (1,035)	
7.50-10 NHS	12	454287	120 (830)	5,655 (2,565)	4,300 (1,950)	4,300 (1,950)	3,395 (1,540)	3,870 (1,755)	3,055 (1,385)	
7.00-12 NHS	12	454212	125 (860)	5,995 (2,720)	4,555 (2,065)	4,555 (2,065)	3,595 (1,630)	4,100 (1,860)	3,235 (1,465)	
7.00-12 NHS	14	4542D7	145 (1000)	6,535 (2,965)	4,970 (2,255)	4,970 (2,255)	3,920 (1,780)	4,470 (2,030)	3,530 (1,600)	
7.50-15 NHS	12	454269	115 (790)	7,690 (3,490)	5,845 (2,650)	5,845 (2,650)	4,615 (2,095)	5,260 (2,385)	4,150 (1,880)	
8.25-15 NS	12	454231	105 (720)	8,680 (3,935)	6,595 (2,990)	6,595 (2,990)	5,210 (2,365)	5,935 (2,690)	4,685 (2,125)	
8.25-15 NHS	14	4542D5	120 (830)	9,385 (4,255)	7,135 (3,235)	7,135 (3,235)	5,630 (2,555)	6,420 (2,910)	5,070 (2,300)	
29x8-15 NHS	12	454216	125 (860)	6,870 (3,115)	5,220 (2,370)	5,220 (2,370)	4,120 (1,870)	4,700 (2,130)	3,710 (1,685)	
30x8-15 NHS	12	454251	125 (860)	6,940 (3,150)	5,275 (2,395)	5,275 (2,395)	4,165 (1,890)	4,745 (2,150)	3,745 (1,700)	
5.70-8 NHS	6	40B206	90 (620)	---	---	1,530 (695)	1,210 (550)	1,415 (640)	1,115 (505)	
5.70-8 NHS	8	40B208	120 (830)	---	1,830 (830)	1,830 (830)	1,445 (655)	1,675 (760)	1,320 (600)	

Size	Service Condition Application Speed			Counterbalanced Lift Truck		Industrial Vehicle Loads					
	Ply Rating	Catalog Number	PSI (kPa)	Front/Drive	Rear/Steer	Smooth Floor Only		Other Than Smooth Floor			
				up to 10 mph (15 km/h & under) lbs. (kg)	up to 15 mph (25 km/h & under) lbs. (kg)	PSI (kPa)	5 mph (10 km/h) lbs (kg)	10 mph (15 km/h) lbs (kg)	PSI (kPa)	5 mph (10 km/h) lbs (kg)	10 mph (15 km/h) lbs (kg)
9.00-20 NHS	12	44P218	95 (660)	11,800 (5,350)	8,950 (4,060)	104 (720)	10,600 (4,810)	10,200 (4,625)	87 (600)	7,850 (3,560)	6,800 (3,085)
9.00-20 NHS	14	44P2E8	110 (760)	12,800 (5,805)	9,750 (4,425)	122 (840)	11,540 (5,235)	11,120 (5,045)	102 (700)	8,550 (3,880)	7,450 (3,380)
10.00-20 NHS	16	44P2E9	115 (790)	14,910 (6,765)	11,330 (5,140)	131 (900)	13,750 (6,235)	13,250 (6,010)	109 (750)	10,200 (4,625)	8,850 (4,015)
11.00-20 NHS	16	44P2E2	110 (760)	15,845 (7,185)	12,040 (5,460)	126 (870)	14,450 (6,555)	13,900 (6,305)	105 (720)	10,700 (4,855)	9,300 (4,220)
12.00-20 NHS	18	44P2E3	115 (790)	18,600 (8,435)	14,100 (6,395)	131 (900)	17,300 (7,845)	16,650 (7,550)	109 (750)	12,800 (5,805)	11,150 (5,060)
12.00-20 NHS	20	44P2A7	130 (900)	19,900 (9,025)	15,100 (6,850)	144 (990)	18,350 (8,325)	17,700 (8,030)	120 (830)	13,600 (6,170)	11,850 (5,375)
10.00-20 NHS	18	472224	130 (900)	16,000 (7,260)	12,200 (5,535)	148 (1020)	14,850 (6,735)	14,300 (6,485)	123 (850)	11,000 (4,990)	9,570 (4,340)
12.00-20 NHS	20	4722A7	130 (900)	19,900 (9,025)	15,100 (6,850)	144 (990)	18,350 (8,325)	17,700 (8,030)	120 (830)	13,600 (6,170)	11,850 (5,375)

Approved Rim Contours

Bias Earthmoving		
Tire Size	Recommended Rim	Approved Rims
13.00-24TG (12 PR)	9.00GR	10.00VA, 8.00TG
13.00-24TG (14 PR)	8.00TG	10.00VA
13.00-24TG (16 PR)	10.00VA	
14.00-24TG (12 PR)	9.00GR	10.00VA, 8.00TG
14.00-24TG (14 PR)	8.00TG	10.00VA
14.00-24TG (16 PR)	10.00VA	
14.00-24NHS*	10.00W	
14.00-25NHS*	10.00/1.5	
LSW330-851	851x254LSW	

* Tube Type

Paver/Sand		
Tire Size	Recommended Rim	Approved Rims
14.00-20DT	10.00W	
16.00-20DT	10.00W	
18.00-25DT	10.00/1.5	
21.00-25DT	15.00/3.0	

Bias Grader Service		
Tire Size	Recommended Rim	Approved Rims
13.00-24TG (12 PR)	9.00GR	10.00VA, 8.00TG
13.00-24TG (14 PR)	8.00TG	10.00VA
13.00-24TG (16 PR)	10.00VA	
14.00-24TG (12 PR)	9.00GR	10.00VA, 8.00TG
14.00-24TG (14 PR)	8.00TG	10.00VA
14.00-24TG (16 PR)	10.00VA	
16.00-24TG (12 PR)	10.00VA	9.00GR
16.00-24TG (14 PR & UP)	10.00VA	
LSW 330-851	851x254LSW	
LSW 360-851	851x254LSW	
LSW 395-851	851x317LSW	

Bias Loader/Dozer Services		
Tire Size	Recommended Rim	Approved Rims
400/70-20	W14L	14, 13, 13SDC
LSW 400-648	648x356LSW	

Bias Container Handling		
Tire Size	Recommended Rim	Approved Rims
14.00-24NHS	10.00W	

Bias Underground Mine/Material Handling		
Tire Size	Recommended Rim	Approved Rims
6.00-9NHS (6.90-9NHS)	4.00E	
6.50-10NHS	5.00F	5.50F
7.50-10NHS (12 PR & BELOW)	5.50F	5.00F
7.50-10NHS (14 PR & UP)	6.00SP	6.00ST
7.00-12NHS	5.00S	
7.50-15NHS	6.0	6.5
8.25-15NHS	6.5	6.50BD
9.00-20NHS	7.0	7.5
10.00-20NHS	7.5	8
11.00-20NHS	8.0	8.5
12.00-20NHS	8.5	8.0, 9.0
12.00-24NHS	8.5	9
14.00-24NHS	10.00W	
29x8-15NHS	5.5	5.50BD
30x8-15NHS	6.0	5.50BD, 5.5
32x12-15NHS	9.75	9.75, 9.75BD
35x15-15NHS ** (16 PR & BELOW)	10.50	11.00BD, 11.00
35x15-15NHS ** (20 PR & UP)	11.50	11.00BD, 11.00
28x9-15NHS	7.0	7.00BD
28x12-15NHS	9.75BD	
32x15-15NHS **	11.50	10.50, 11.00BD, 11.0
36x11-15NHS	7.5	7.50BD
44x18.00-20NHS	15.00T	
42x21.00-22NHS	18.00	

** Tubeless

Bias Forestry		
Tire Size	Recommended Rim	Approved Rims
18.4-26	DW16A	
18.4-34	DW16A	DW15A
23.0-26	DW20B	
24.5-32 (12 PR & BELOW)	DH21	DW21A, DW21B, DH21B, DH21H, DH21HB
24.5-32 (16 PR & UP)	DH21	DH21B, DH21H, DH21HB
28L-26	DW25B	
30.5L-32 (12 PR & BELOW)	DH27	DW27B, DH27B, DH27H, DH27HB
30.5L-32 (16 PR & UP)	DH27	DH27B, DH27H, DH27HB
DH35.5-32	DH31	DH31B, DH31H, DH31HB
66x43.00-25NHS	36.0TH	
67x34.00-25NHS	30.0TH	
DH73x44.00-32	DH36B	DH36HB, 36DWM
DH73x50.00-32	DH44	DW44A, DW44B, 44DWM, DH44H, DH44HB, DH44B

Approved Rim Contours

Radial Backhoe		
Tire Size	Recommended Rim	Approved Rims
340/80R18	11	W10H, W11
400/70R18	W13	W12
440/80R24	W14L	W15L
440/80R28	W14L	W15L
460/70R24	W14L	W15L
480/80R26	W15L	W16L, DW15A, DW16A
500/70R24	W16L	W15L, DW16A, W16A
500/85R24	W16L	W15L, DW16A, W16A
540/70R24	W16L	DW18A, W18L, W16A, DW16A
19.5LR24	DW16L	DW16A, W16A

Bias Backhoe		
Tire Size	Recommended Rim	Approved Rims
9.00-10HS	6.00F (2-piece)	5.50F (2-piece)
11.00-16SL	W8L	8LB, W10L, 10LB
12.4-16	W10L	10LB
14.9-24	W13	W12
16.9-24	W15L	
16.9-28	W15L	W14L
16.9-30	W15L	DW15A, W14L, DW14A
18.4-24	W16L	W15L, W16A
18.4-26	DW16A	W15L, DW15A
18.4-28	W16L	W16A, W15L
17.5L-24	W15L	
19.5L-24 (10 PR & BELOW)	DW16A	W16L, W15L
19.5L-24 (12 PR & UP)	DW16A	
11L-15SL	8LB	10LB
11L-16SL	W8L	8LB, W10L, 10LB
21L-24 (10 PR & BELOW)	DW18A	W18L
21L-24 (12 PR & UP)	DW18A	
21L-28 (10 PR)	DW18A	W18L
21L-28 (14 PR)	DW18A	DW18L
480/45-17	16.00	
420/70-4	W13	W12, W14L
14.5/75-16.1SL	16.1xW11C	
10.5/80-18	W9	9, W8
12.5/80-18	W9	11
LSW495-762	30xDW15A	
LSW320-597	597x267LSW	

Bias Skid Steer		
Tire Size	Recommended Rim	Approved Rims
5.70-12NHS	4.50I-70	4.50I-90, 5JA
7.00-15SS	5.50F	
8.25-15NHS	6LB	
10-16.5NHS	8.25 (15°)	
12-16.5NHS	9.75 (15°)	
14-17.5NHS	10.50 (15°)	
15-19.5NHS	11.75 (15°)	12.25 (15°)
18x8.50-10	7.00 I-55	7.00 I-70, I-90
20x8.00-10NHS	7.00 I-70	6.00E, 7.00E, 7.00 I-55, 7.00 I-90
23x8.50-12NHS	7.00 I-70	7.00 I-90, 7JA
23x8.50-14NHS	7.00 I-70	7.00 I-90, 7JA
26x12.0-12NHS	10.50 I-70	8½ JA, 10.50 I-90, 8.50 I-70, 8.50 I-90
27x8.50-15NHS	7JA	
27x10.50-15NHS	8LB	
27x12.5-15NHS	10LB	
28x8.50-15NHS	7JA	
30.5x12.00-16.5NHS	9.75 (15°)	
31x15.50-15NHS	13LB	
33x14.50-16.5NHS	12.00 (15°)	
33x15.50-16.5NHS	12.00 (15°)	
43x16.00-20NHS	W14LH	W14L
LSW265-521	521x210LSW	
LSW305-546	546x248LSW	
LSW350-597	597x267LSW	
LSW385-648	648x317LSW	

Bias Compactor		
Tire Size	Recommended Rim	Approved Rims
6.00-16NHS	4.00E	4.25KA, 4.50E
8.5/90-15K	5.50F	
7.50-15NHS	6.0	6.5
9.00-20NHS	7.0	7.5
11.00-20NHS	8.0	8.5

WARNING

The task of servicing tires and wheels can be extremely dangerous and should be performed by trained personnel only, using the correct tools and following specific procedures. Failure to heed this warning could lead to serious injury or death. Read and understand the “Safety Information” in this catalog. We urge that the following is mandatory reading for all those involved in the servicing of tires and wheels:

Department of Labor Occupation Safety and Health Administration (OSHA) 29 CFR part 1910.177, titled Servicing of Single Piece and Multi-piece Rim Wheels. NOTE: Single piece rims have a rim made out of a single piece of material as shown on page S:20 and multiple-piece rims have a loose flange or flanges and lock ring as depicted on pages S:20 and S:21.

Rubber Manufacturers Association, “Care and Service of Farm Tires”
 Rubber Manufacturers Association, “Care and Service of Off-the-Highway Tires”
 Rubber Manufacturers Association, “Care and Service of Highway Truck Tires”
 Rubber Manufacturers Association, “Demounting and Mounting”

Procedure Wall Charts:

Automobile and Light Truck Tires on Single piece Rims
 Truck Tires (Radial and Bias ply)
 Truck/Bus Tires
 Agricultural Tires

We have shown step by step procedures for the servicing of single piece, three piece and five piece rims with the emphasis on safety operations for these rims in this catalog. Information on other types of rims can be found in the above RMA publications or in the catalogs published by the rim manufacturer. This and any other safety related information in Titan’s catalog is issued as assistance to supervisory and operational personnel in the actual tire/rim service environment. The responsibility for implementation of this safety information rests with operational and supervisory personnel carrying out the actual service work. Read and fully understand all procedures before attempting tire/wheel servicing.

If you have any doubt about the correct, safe method of performing any step in the demounting, mounting, adding or removing fill, or inflating process **STOP!** Seek out expert assistance from a qualified person.



Wear protective gloves, footwear, safety glasses, hearing protection and head gear when servicing tires and wheels.

Further references explaining safety procedures can be found in literature published by the Rubber Manufacturers Association, Washington D.C.; the Tire Association of North America, Washington D.C.; the National Wheel and Rim Association, Jacksonville, FL; and OSHA, Washington D.C.

SAFETY FIRST!

IMPORTANT!

THIS IS THE FIRST STEP IN ALL DEMOUNTING OPERATIONS

Always remove the valve core and exhaust all air from a single tire and from **both** tires of a dual assembly. Check the valve stem by running a piece of wire through the stem to make sure it is not plugged.

READ AND FOLLOW SAFETY INSTRUCTIONS. FAILURE TO DO

! COULD RESULT IN SERIOUS INJURY.

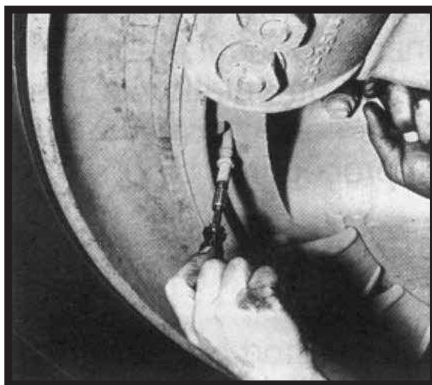
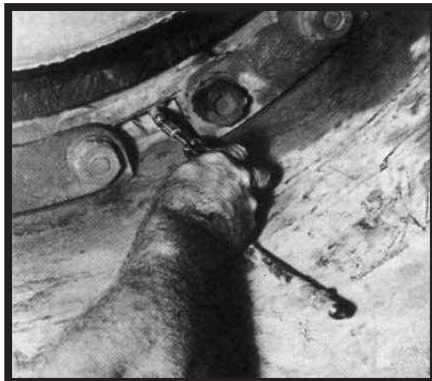

Removing valve core from single piece wheel.

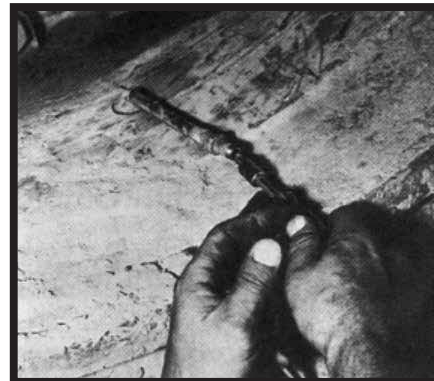

Running wire through the stem of an single piece wheel.

GENERAL WARNINGS



This symbol indicates a warning message.



Failure to heed warnings could lead to serious injury or death.

- The task of servicing tires and wheels can be extremely dangerous and should be performed by trained personnel only, using the correct tools, and following the procedures presented here and in manufacturers' catalogs, instruction manuals, or other industry and government instruction material.
- Several types of tire changing equipment are available. Installers should be fully trained in correct operating procedures and safety instructions for the specific machine being used. Always read and understand any manufacturer's warning contained in the product literature or posted on the equipment.
- Always use approved tire and rim combinations for sizes and contours.
- Always wear personal protection equipment such as gloves, footwear, eye protection, hearing protection and head gear, when servicing tire and wheels.
- Never exceed manufacturer's recommended tire inflation pressure.
- Always use proper lifting techniques and mechanized lifting aids to move heavy components and assemblies.
- Always take care when moving tires and wheels that other people in the area are not endangered.
- Never leave a tire, wheel or assembly unsecured in a vertical position.
- Parts that are cracked, worn, pitted with corrosion or damaged must be destroyed, discarded and replaced with good parts.
- Always exhaust all air from the tire prior to demounting.
- Never try to repair wheel, rim or tire component parts. Replace all damaged, worn or suspect parts with good parts.
- Never reinflate a tire that has lost air pressure or has been reinflated without determining and correcting its problem.
- When conducting routine tire inspections also conduct a visual inspection of wheel and rim components. Always correct any non-conformities found.
- Always use restraining devices (safety cages) when inflating tires.
- Never exceed 35 psi when seating beads.
- Misapplication, improper inflation, overloading and exceeding maximum speed may cause tire failure.
- Always inspect both sides of the tire to assure proper bead seat.

GENERAL WARNINGS

WARNING

15.3" DIAMETER: 9" WIDTH EUROPEAN RIMS
Certain European implement equipment has been imported into North America with unique diameter rims for which no North American produced replacement tire sizes are available.

Any attempt to mount and inflate 15" nominal bead diameter tires on these rims may ultimately cause one of the tire beads to break, possibly resulting in serious physical injury or even death.

The rims in question are 15.3" in diameter and 9" wide. However, rims manufactured in 1981 and earlier are marked as 15" diameter; only those manufactured in 1982 and 1983 are marked as 15.3" diameter. **The key to avoiding this potentially dangerous situation is the 9" width.** The U.S.A. (or Canada) wheel industry does not manufacture a 9" width rim for implement use.

The European tires sizes that may be mounted on these rims are:

10.0/75 – 15.3 (or 15)
10.5/85 – 15.3
11.5/80 – 15.3 (or 15)
12.5/80 – 15.3

U.S.A. (OR CANADA) PRODUCED IMPLEMENT TIRES ARE NOT TO BE MOUNTED ON ANY 9" WIDE IMPLEMENT RIM.

WARNING

There is a danger of serious injury or death if a tire of one bead diameter is installed on a rim or wheel of a different rim diameter.

Always replace a tire with another tire of exactly the same bead diameter designation and suffix letters. For example: A 16" tire goes on a 16" rim. Never mount a 16" tire on a 16.1" or 16.5" rim. A 16.5" tire goes on a 16.5" rim. Never mount a 16.5" tire on a 16" or 16.1" rim.

While it is possible to pass a 16" diameter tire over the lip or flange of a 16.1" or 16.5" size diameter rim, it cannot be inflated enough to position itself against the rim flange. If an attempt is made to seat the tire bead by inflating, the tire bead will break with explosive force and could cause serious injury or death.

Rims of different diameters and tapers cannot be interchanged. The following diagram illustrates the difference between rims of two different tapers and diameters:

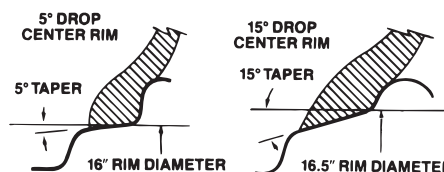

The following diagram shows how beads of a 16" tire will not seat on a 16.5" rim. The beads cannot be forced out against the rim flanges by using more air pressure because this will break the beads and the tire will explode with force sufficient to cause serious injury or death.

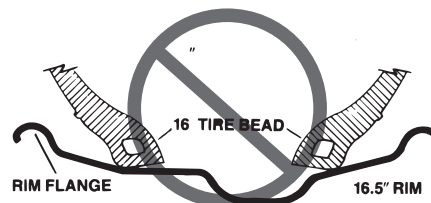

GENERAL WARNINGS

WARNING

STAY OUT OF THE TRAJECTORY AS INDICATED BY SHADED AREA. ALWAYS USE A SAFETY CAGE OR OTHER RESTRAINING DEVICE IN COMPLIANCE WITH OSHA REGULATIONS.

Note: Under some circumstances, the trajectory may deviate from its expected path.

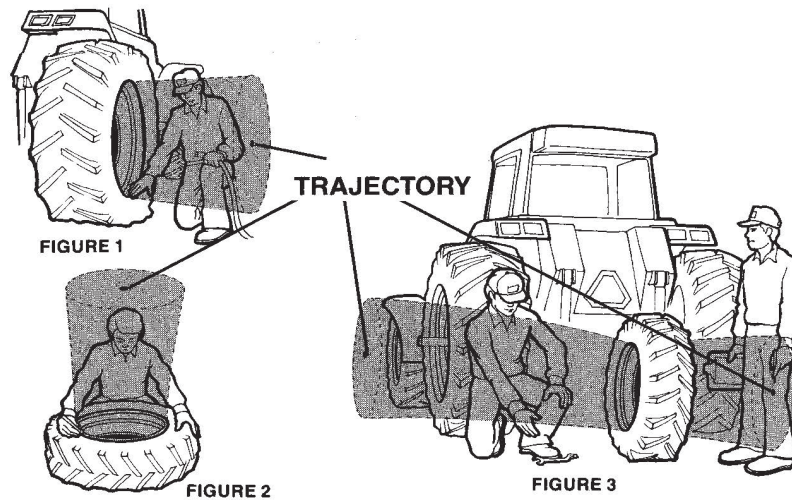

NEVER stand, lean or reach over the assembly during inflation.

TO DETERMINE COMPATIBLE RIM WIDTH FOR TIRE SIZES

Determine the vehicle's actual rim width by measuring, in inches, the distance between the vertical bead flanges as shown. A simple ruler or yardstick may be used, as rims are manufactured in half inch increments of width.

Find permissible replacement tire sizes in RMA's Care and Service Tires Manual (Washington, D.C.). Most tires will fit on more than one rim width.

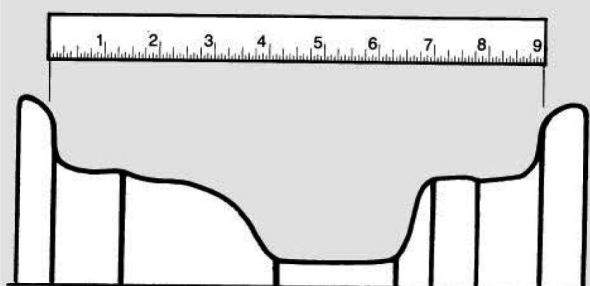

Safety Information

Demounting Single Piece Wheel and Tire Assemblies (On-The-Vehicle)

Tools Required: Cap and core removal tools, bead unseating tool, two 36" tire irons, two 18" tire irons, vegetable-based lubricant.

! If you have any doubt about the correct, safe method of performing any step in the demounting, mounting, adding or removing fill, or inflating process STOP! Seek out expert assistance from a qualified person.

! Due to the variety of vehicle/equipment configurations and the range of conditions and situations under which on-vehicle demounting (wheel/tire assembly still attached to vehicle or equipment) can occur, proper procedures for blocking, jacking, cribbing of the ve-

hicle/ equipment must be done in accordance with the manufacturers operator's manual, maintenance manual or the information as provided by the vehicle/equipment manufacturer.

Tools required: Jack, cribbing, blocking or other items as needed to jack and block the vehicle/equipment per the manufacturers instructions, hydraulic demounting tool, hooked tire iron, pry bar and lifting device or boom truck.

1. Remove the fluid fill from the tire. Deflate the tire by removing the valve core housing. For tube-type tires, remove the rim nut and push the valve through the valve hole.

! Always completely deflate tire (both tires of a dual assembly) by removing valve core(s) from valve(s) before attempting any demounting operation. Check the valve stem by running a piece of wire through the stem to make sure it is not plugged.

! Stand clear of trajectory danger zone when deflating (page S:5).



2. After the tire is completely deflated, place a hydraulic "bead unseating" tool between the tire bead and rim flange and force the bead off the bead seat. Be careful not to damage the tire's bead area. The beads should be unseated on both sides of the rim.

! Demounting tools apply pressure to rim flanges to unseat tire beads. Keep your fingers clear. Always stand to one side when you apply hydraulic pressure.

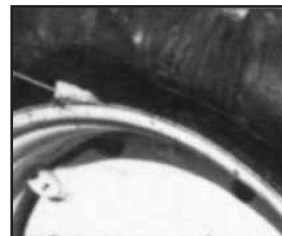

3. Thoroughly lubricate the tire bead area and rim flange with a vegetable-based lubricant.

! Never use a petroleum-based lubricant. Only use vegetable-based lubricant.



4. Lock the wheel with the valve at the top. At the bottom, force the outside bead into the well. At the top, insert long tire irons under the bead and pry the bead over the rim flange. Take small bites and avoid extremely hard prying, which will damage the tire bead.

! Do not release your grip on either iron, as they may spring back.

! Keep fingers clear of pinch points.



5. After the first section of the bead is over the rim flange, use one tire iron to pry the next section over the flange. Do not attempt to pry too large a section of the bead over the rim flange at one time. Continue prying tire over rim flange until the complete tire is on the outside of the rim flange.

Demounting Single Piece Wheel and Tire Assemblies (On-The-Vehicle)

Tools Required: Cap and core removal tools, bead unseating tool, two 36" tire irons, two 18" tire irons, vegetable-based lubricant.

! If you have any doubt about the correct, safe method of performing any step in the demounting, mounting, adding or removing fill, or inflating process STOP! Seek out expert assistance from a qualified person.

! Do not release your grip on either iron, as they may spring back.

! Keep fingers clear of pinch points.



7. To remove the tire completely from the wheel, insert tire irons under the inside bead at the side of the tire. Pry the rest of the inside bead over the rim flange. When starting this operation, be sure that the bead area on the opposite side of the tire is down in the well of the rim.

! Do not release your grip on either iron, as they may spring back.

! Keep fingers clear of pinch points.

6. For tube-type tires, pull the tube out of the casing, starting at the bottom. If only the tube requires repair or replacement, this can be removed, repaired, and replaced in the tire without removing the tire completely from the wheel. Before reinstalling the tube, thoroughly inspect the inside of the casing for damage or other foreign material. Remove any remaining fluid from inside the tire.

! Tires or tubes with excessive or uneven wear, cracks, tears, punctures, blisters and or other damage may explode during inflation or service. If tire or tube failure potential is suspected, destroy the tire and replace with known good tire or tube of correct size, type and manufacturer for assembly, machine, and application.

Safety Information

Mounting Single Piece Wheel and Tire Assemblies (On-The-Vehicle)

Tools Required: vegetable-based lubricant, wire brush, two 36" tire irons, two 18" tire irons, rubber mallet, extension hose with in-line gauge and clip-on air chuck, air/water inflation gauge, restraining device.

! If you have any doubt in the correct, safe method of performing any step in the demounting, mounting, adding or removing fill, or inflating process STOP! Seek out expert assistance from a qualified person.

! ALWAYS replace a tire on a rim with another tire of exactly the same rim diameter designation.

! Rims of different diameters and tapers CANNOT be interchanged.

! Remove water and foreign material from tire. Tubes or tires with excessive wear, cracks, tears, punctures, blisters, or other damage may explode during inflation or service. If tube or tire failure potential is suspected, render the tube or tire unusable and replace with known good tube or tire.



1. Thoroughly lubricate the tire bead area and rim flange with a vegetable-based lubricant.

! Never use petroleum-based lubricant. Only use vegetable-based lubricant.

2. With a wire brush, clean and inspect rim for fatigue cracks. Replace any cracked, badly worn, damaged and severely rusted rims or wheels. Coat the rim with paint or a rust inhibitor if necessary.

! Follow procedures and safety precautions of the paint manufacturer.

! Do not, under any circumstances, attempt to re-work, weld, heat, or braze any rim base or wheel components.

3. Before placing tire on rim, be sure the rim's valve hole is at the bottom of wheel. Also take care to ensure directional bead tires are mounted for correct rotation direction.

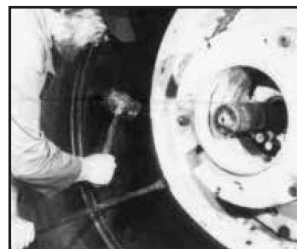

4. To put the tire on the wheel, place the inner bead over the flange at the top. Be sure the bead is not "hung up" on the bead seat, instead the bead is guided into the rim well, while the tire irons and/or rubber mallet are used to work the first bead over the rim. With the first bead on the rim, pull the tire toward the outside of the rim as far as possible to make room for the tube.

! Keep fingers clear of pinch points.

! Keep a firm grip on the tire iron(s), as they may spring back.



5. Tubeless type tires, skip to step seven. For tube-type tires, be sure the valve is at the bottom of the wheel. Align the stem with the valve hole and starting at the bottom, place the tube in the tire. Place the valve in valve hole and screw the rim nut in place. Be sure that the tube is well inside the rim before proceeding to the next step.

Mounting Single Piece Wheel and Tire Assemblies

(On-The-Vehicle) Tools Required: vegetable-based lubricant, wire brush, two 36" tire irons, two 18" tire irons, rubber mallet, extension hose with in-line gauge and clip-on air chuck, air/water inflation gauge, restraining device.

! If you have any doubt in the correct, safe method of performing any step in the demounting, mounting, adding or removing fill, or inflating process STOP! Seek out expert assistance from a qualified person.

6. In tube-type tires, the tube should be partially inflated and areas that contact the rim should be relubricated to prevent localized stretching.

! Never use petroleum-based lubricant. Only use vegetable-based lubricant. Keep fingers clear of pinch points.



7. Starting at the top, use the tire irons to lift the outer bead up and over the rim flange, then down into the rim well. Be careful not to pinch the tube in this operation.

! Keep fingers clear of pinch points.

! Do not release your grip on either iron, as they may spring back.



8. After getting the first section of the outer bead into the rim well, remove the tire iron and place one hand against that section to hold it in then pry the remainder of the bead over the flange with the tire iron in the other hand.

! Keep fingers clear of pinch points.

! Keep firm grip on tire iron(s), as they may spring back.

9. With the valve stem at the bottom, lower the jack until the tire is centered on the rim. Centering of the tire and rim assembly is extremely important to prevent broken beads.



10. Place a safety restraint over the rim and tire. Using an extension hose with an in-line air gauge and clip-on chuck (with valve core removed), inflate the tire to seat the beads. Do not exceed 35 psi. Check for correct concentric centering of tire on rim.

For tubeless tires, successful mounting depends on how well the shape of the tire has been maintained. If the beads are in or near their molded position, they can be seated by inflating the tire, through the valve spud. Where the beads have been squeezed together, the use of an inflator ring (either horizontally or vertically) will be required to provide a seal between the tire bead and rim.

! If assembly is incorrect, – STOP – DEFLATE – CORRECT THE ASSEMBLY – repeat procedure.

11. Raise the vehicle and rotate wheel assembly to have the valve at the top. **If the tire is tube-type**, completely deflate by removing the valve core housing to remove buckles and uneven stresses from the tube and flap before reinflation.

12. If assembly is correct, re-insert the valve core (for tube-type tires) and continue to inflate to recommend pressure.

! If assembly is incorrect – STOP – DEFLATE – CORRECT THE ASSEMBLY – repeat procedure.

! Stand clear of trajectory danger zone when inflating (page S:5).

! Never inflate beyond manufacturer's recommended tire pressure.

NOTE: A filter on the air inflation equipment to remove moisture from the airline prevents corrosion. Check the filter periodically to be sure it's functioning properly.

Safety Information

Demounting Single Piece Wheel and Tire Assemblies (Off-The-Vehicle)

Tools Required: Cap and core removal tools, bead unseating tool, vegetable-based lubricant, two 18" tire irons.

⚠ If you have any doubt in the correct, safe method of performing any step in the demounting, mounting, adding or removing fill, or inflating process STOP! Seek out expert assistance from a qualified person.

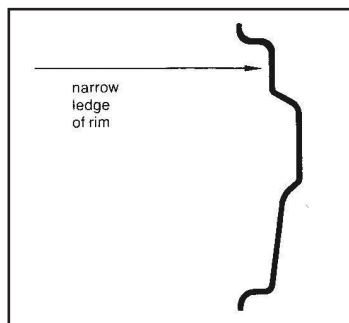

1. Remove any fill from the tire. Completely deflate tire by removing valve core from valve before attempting any demounting operation. Check the valve stem by running a piece of wire through the stem to make sure it is not plugged. Lay the assembly on the floor with the narrow ledge on the bottom.

⚠ Stand clear of trajectory danger zone when deflating (page S:5 & S:17).



2. Drive a bead unseating tool between the tire bead and rim flange, being careful not to damage the tire bead area. After the bead has been completely released around the tire, turn the tire and rim over and repeat the bead unseating procedure with the narrow ledge up.

⚠ Keep fingers clear of pinch points.



3. With the narrow ledge on top, thoroughly lubricate the rim flange and tire bead area with a vegetable-based lubricant.

⚠ Never use petroleum-based lubricant. Only use vegetable-based lubricant.



4. Force the part of the bead that is directly across from the valve into the well. Starting at the valve, pry the bead over the rim flange using two 18" long tire irons. Take small bites to avoid damaging the bead. Continue until the top bead is completely over the rim flange.

⚠ Keep a firm grip on tire irons as they may spring back.

⚠ Keep fingers clear of pinch points.



5. For tube-type tires, bring the assembly to an upright position and pull the tube out of the tire. If only the tube requires repair or replacement, this can be removed, repaired, and replaced in the tire without removing the tire completely from the rim. Thoroughly inspect the inside of the casing for damage or other foreign material. Remove any remaining fluid from inside the tire.

⚠ Tire or tubes with excessive or uneven wear, cracks, tears, punctures, blisters or other damage may explode during inflation or service. If tire or tube failure potential is suspected, destroy the tire and replace with known good tire or tube of correct size, type and manufacturer for assembly, machine, and application.

Demounting Single Piece Wheel and Tire Assemblies (Off-The-Vehicle)

Tools Required: Cap and core removal tools, bead unseating tool, vegetable-based lubricant, two 18" tire irons.

! If you have any doubt in the correct, safe method of performing any step in the demounting, mounting, adding or removing fill, or inflating process STOP! Seek out expert assistance from a qualified person.



6. To completely remove the tire from the rim, turn assembly over so the narrow ledge is down and lubricate the second tire bead and rim flange. Be sure the bead still on the rim is in the rim well and insert the tire irons under the opposite side of the bead. Work the rim slowly out of the tire by taking small bites alternately using both tire irons.

! Never use petroleum-based lubricant. Only use vegetable-based lubricant.

! Keep a firm grip on the tire irons, as they may spring back.

! Keep fingers clear of pinch points.

Safety Information

Mounting Single Piece Wheel and Tire Assemblies (Off-The-Vehicle)

Tools required: Two 18" tire irons, wire brush, locking pliers, vegetable-based lubricant, valve retrieval tool (tube-type tires), extension hose with in-line gauge and clip-on air chuck, air/water inflation gauge, safety cage.

! If you have any doubt in the correct, safe method of performing any step in the demounting, mounting, adding or removing fill, or inflating process STOP! Seek out expert assistance from a qualified person.

! ALWAYS replace a tire on a rim with another tire of exactly the same rim diameter designation.

! Rims of different diameters and tapers CANNOT be interchanged.

! Remove water and foreign material from tire. Tubes or tires with excessive wear, cracks, tears, punctures, blisters or other damage may explode during inflation or service. If tube or tire failure potential is suspected, render the tube or tire unusable and replace with known good tube or tire.

1. With a wire brush, clean and inspect rim for fatigue cracks. Replace all cracked, badly worn, damaged and severely rusted rims and wheels. Coat the rim and components with paint or a rust inhibitor if needed.

! Follow procedures and safety precautions of the paint manufacturer.

! Do not, under any circumstances, attempt to rework, weld, heat or braze any rim base or wheel components.

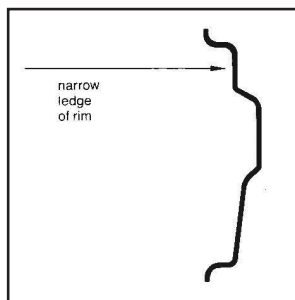

2. Lay the rim on the floor with the narrow ledge on the top. Thoroughly lubricate the tire bead area and rim flange with a vegetable-based lubricant.

! Never use petroleum-based lubricant. Only use vegetable-based lubricant.



3. Push the bottom bead over the rim flange as far as possible. Use 18" tire irons to work the first tire bead completely over the rim flange, taking small bites and being careful not to damage the bead. Make sure directional tread tires are mounted for correct rotation direction.

! Keep a firm grip on the tire irons as they may spring back.

! Keep fingers clear of pinch points.



4. For tube-type tires, partially inflate the tube and insert it into the tire casing with the valve located near the valve hole in the rim. Attach a valve retrieval tool to the valve and thread the tool through the valve hole. (Inserting the tube and attaching the tool may be eased by placing a block under the tire.)



5. Starting opposite the valve, use tire irons to lever the top bead over the rim flange and down into the rim well. Be careful to avoid pinching the tube with tire irons. Locking pliers may be used to resist tire slipping back off rim.

! Keep a firm grip on the tire irons as they may spring back.

! Keep fingers out of pinch points.

Mounting Single Piece Wheel and Tire Assemblies (Off-The-Vehicle)

Tools required: Two 18" tire irons, wire brush, locking pliers, vegetable-based lubricant, valve retrieval tool (tube-type tires), extension hose with in-line gauge and clip-on air chuck, air/water inflation gauge, safety cage.

 If you have any doubt in the correct, safe method of performing any step in the demounting, mounting, adding or removing fill, or inflating process STOP! Seek out expert assistance from a qualified person.

6. When the bead is well started, lubricate the remaining unmounted portion of the tire bead and rim flange. Taking small bites, spoon the tire bead over the rim flange until the final section drops over at the valve.

 Never use petroleum-based lubricant. Only use vegetable-based lubricant.

 Keep a firm grip on the tire irons as they may spring back.

 Keep fingers out of pinch points.

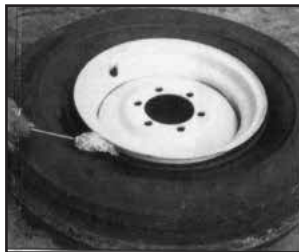

7. Thoroughly lubricate the tire bead area and rim bead-seats on both sides of the tire.

 Never use petroleum-based lubricant. Only use vegetable-based lubricant.

8. Centering of the tire and rim assembly is extremely important to prevent broken beads.

9. Place the tire in a safety cage. Using an extension hose with an in-line air gauge and clip-on chuck (with valve core removed), inflate the tire to seat the beads. Do not exceed 35 psi. Check for correct concentric centering of tire on rim. **For tubeless tires**, successful mounting depends on how well the shape of the tire has been maintained. If the beads are in or near their molded position, they can be seated by inflating the tire, through the valve spud. Where the beads have been squeezed together, the use of an inflator ring (either horizontally or

vertically) will be required to provide a seal between the tire bead and rim.

 If assembly is incorrect – STOP – DEFLATE – CORRECT THE ASSEMBLY – repeat procedure.

10. If the tire is tube-type, completely deflate by removing the valve core housing to remove buckles and uneven stresses from the tube and flap before reinflation.

11. If assembly is correct, re-insert the valve core and continue to inflate to recommended pressure.

 If assembly is incorrect – STOP – DEFLATE – CORRECT THE ASSEMBLY – repeat procedure.

 Stand clear of trajectory danger zone when inflating (page S:5 & S:17).

 Never inflate beyond manufacturer's recommended tire pressure.

NOTE: A filter on the air inflation equipment to remove moisture from the airline prevents corrosion. Check the filter periodically to be sure it's functioning properly.

Safety Information

WARNING

The task of servicing tires and wheels can be extremely dangerous and should be performed by trained personnel only, using the correct tools and following specific procedures. Failure to heed this warning could lead to serious injury or death. Read and understand the “Safety Information” in this catalog. We urge that the following is mandatory reading for all those involved in the servicing of tires and wheels:

Department of Labor Occupation Safety and Health Administration (OSHA) 29 CFR part 1910.177, titled Servicing of Single Piece and Multi-piece Rim Wheels. NOTE: Single piece rims have a rim made out of a single piece of material as shown on page S:20 and multiple-piece rims have a loose flange or flanges and lock ring as depicted on pages S:20 and S:21.

Rubber Manufacturers Association, “Care and Service of Farm Tires”
 Rubber Manufacturers Association, “Care and Service of Off-the-Highway Tires”
 Rubber Manufacturers Association, “Care and Service of Highway Truck Tires”
 Rubber Manufacturers Association, “Demounting and Mounting”

Procedure Wall Charts:

Automobile and Light Truck Tires on Single piece Rims
 Truck Tires (Radial and Bias ply)
 Truck/Bus Tires
 Agricultural Tires

We have shown step by step procedures for the servicing of single piece, three piece and five piece rims with the emphasis on safety operations for these rims in this catalog. Information on other types of rims can be found in the above RMA publications or in the catalogs published by the rim manufacturer. This and any other safety related information in Titan’s catalog is issued as assistance to supervisory and operational personnel in the actual tire/rim service environment. The responsibility for implementation of this safety information rests with operational and supervisory personnel carrying out the actual service work. Read and fully understand all procedures before attempting tire/wheel servicing.

If you have any doubt about the correct, safe method of performing any step in the demounting, mounting, adding or removing fill, or inflating process **STOP!** Seek out expert assistance from a qualified person.



Wear protective gloves, footwear, safety glasses, hearing protection and head gear when servicing tires and wheels.

Further references explaining safety procedures can be found in literature published by the Rubber Manufacturers Association, Washington D.C.; the Tire Association of North America, Washington D.C.; the National Wheel and Rim Association, Jacksonville, FL; and OSHA, Washington D.C.

SAFETY FIRST!

IMPORTANT!

THIS IS THE FIRST STEP IN ALL DEMOUNTING OPERATIONS

Always remove the valve core and exhaust all air from a single tire and from **both** tires of a dual assembly prior to loosening the first rim clamp nut. Check the valve stem by running a piece of wire through the stem to make sure it is not plugged.



READ AND FOLLOW SAFETY INSTRUCTIONS.



FAILURE TO DO SO COULD RESULT IN SERIOUS INJURY.

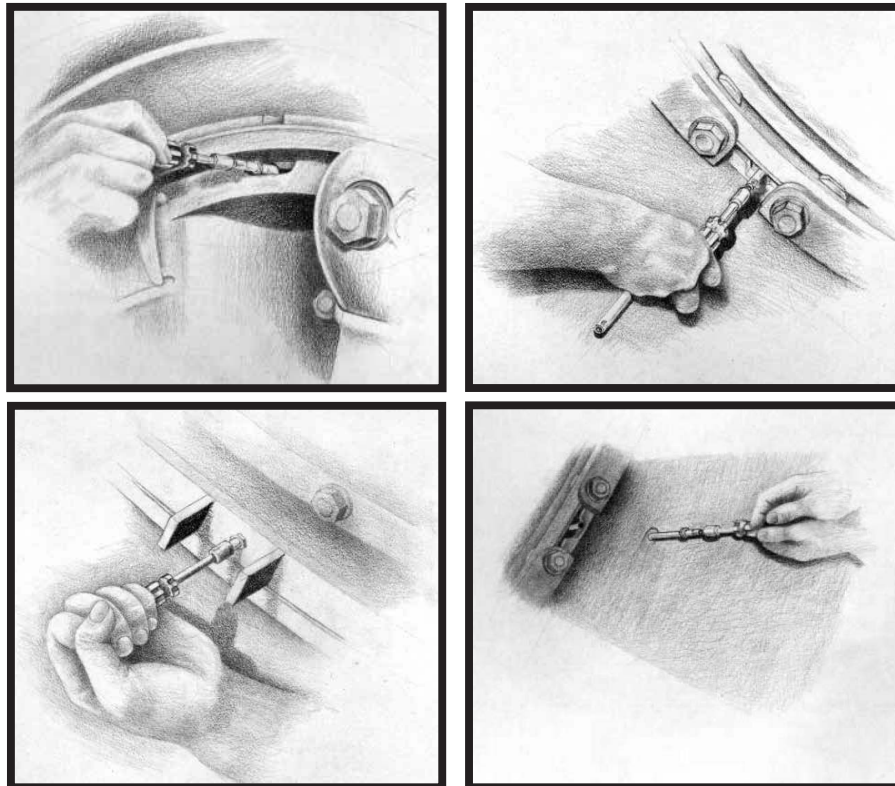

GENERAL WARNINGS



This symbol indicates a warning message.



Failure to heed warnings could lead to serious injury or death.

- The task of servicing tires and wheels can be extremely dangerous and should be performed by trained personnel only, using the correct tools, and following the procedures presented here and in manufacturer's catalogs, instruction manuals, or other industry and government instruction material.
- Always use approved tire and rim combinations for sizes and contours.
- Always wear personal protection equipment such as gloves, footwear, eye protection, hearing protection and head gear when servicing tire and wheel components.
- Never exceed manufacturer's recommended tire inflation pressure. • Always use proper lifting techniques and mechanized lifting aids to move heavy components and assemblies. • Always take care when moving tires and wheels that other people in the area are not endangered. • Never leave a tire, wheel or assembly unsecured in a vertical position.
- Parts that are cracked, worn, pitted with corrosion or damaged must be destroyed, discarded and replaced with good parts.
- Always exhaust all air from the tire prior to demounting.
- Never try to repair wheel, rim or tire component parts. Replace all damaged, worn or suspect parts with good parts.
- Never reinflate a tire that has lost air pressure or has been run flat without determining and correcting the problem.
- When conducting routine tire inspections also conduct a visual inspection of wheel and rim components. Always correct any non-conformities.
- Always verify that part numbers and size designation of component parts are correctly matched for the assembly. See pages S:23 and S:24 for part number location.
- Always place wheel and tire assemblies in restraining devices when inflating tires. See page S:19, item 11.

WARNING

STAY OUT OF THE TRAJECTORY AS INDICATED BY SHADED AREA. ALWAYS USE A SAFETY CAGE OR OTHER RESTRAINING DEVICE IN COMPLIANCE WITH OSHA REGULATIONS.

Note: Under some circumstances, the trajectory may deviate from its expected path.

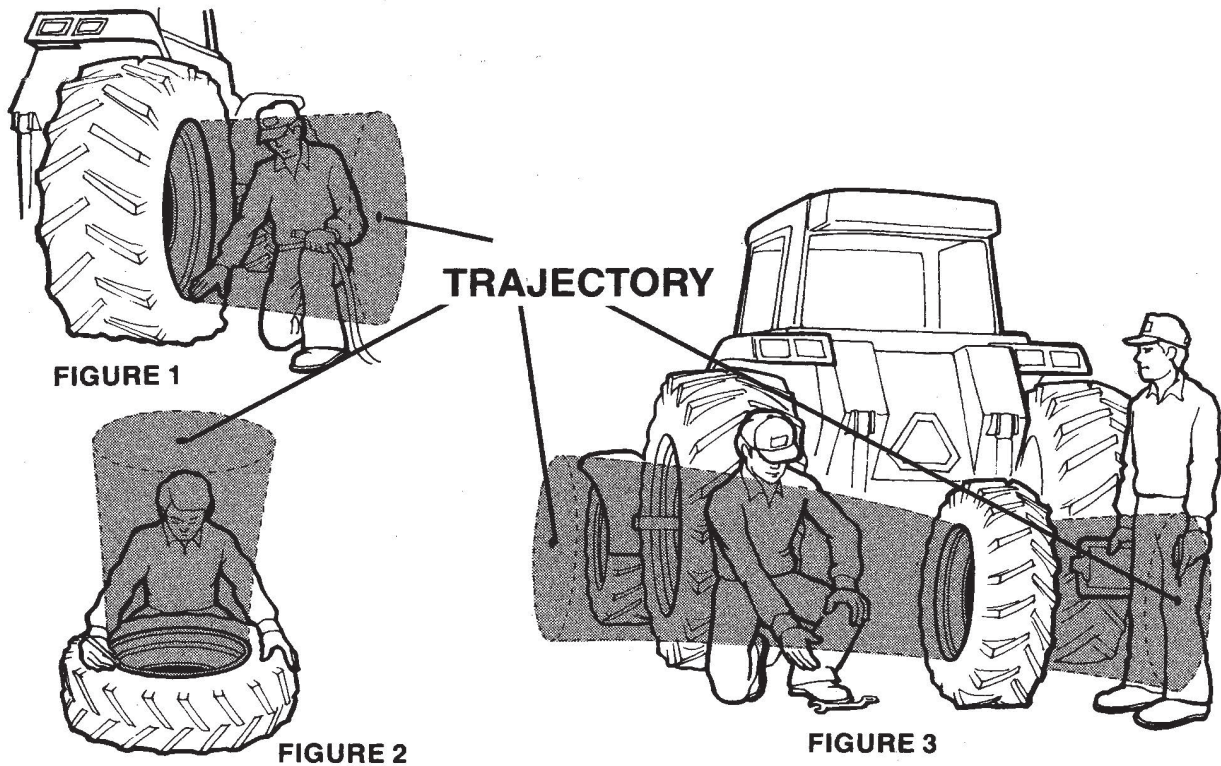

 Never stand, lean or reach across the potential tire and wheel component trajectory danger zones, as shown.

- Additional safety information can be found in literature published by the Rubber Manufacturer's Association, Washington, D.C.; The National Tire Dealer and Retreading Association, Washington, D.C.; The National Wheel and Rim Association, Jacksonville, FL.; and OSHA, Washington, D.C.
- Always completely deflate the tire (both tires of a dual tire assembly) by removing the valve core(s) from valve(s) before attempting any demounting or disassembling. Check the valve stem by running a piece of wire through the stem to make sure it is not plugged.

 Note: Under some circumstances, the trajectory may deviate from its expected path. Always use a safety cage or other restraining device in compliance with OSHA regulations.

Safety Information

Tools and Equipment Required

The following tools and equipment are required to service the various types of multi-piece rims included in this section of the catalog.

- A. Hard wood blocks
- B. A valve extension tool
- C. A set of cap and core removal tools
- D. A wire brush
- E. Chain or cable slings of adequate length
- F. Bead Lubricant (Non-Petroleum base)
- G. A mallet or its equivalent
- H. Inflation hose with clip-on chuck, in-line gauge and control valve
- I. Piece of wire (to unpluck valve stem)

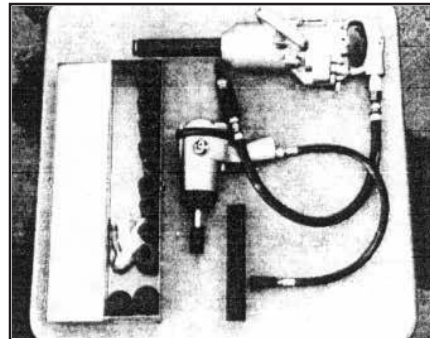

the bead breakers and hydraulic rams.

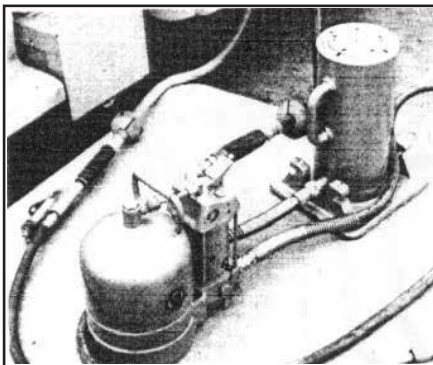

Plus the following:

1. Air-Hydraulic Pump and 50-ton jack. Air supplied to the pump develops hydraulic pressure to lift the jack. This equipment is essential in servicing extra-heavy construction equipment.

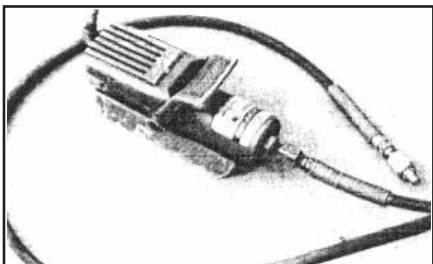

struction equipment.

2. Air-Hydraulic Pump, activates hydraulic tools such as

3. Air wrenches and their sockets are used to tighten and loosen nuts on wheels assemblies.

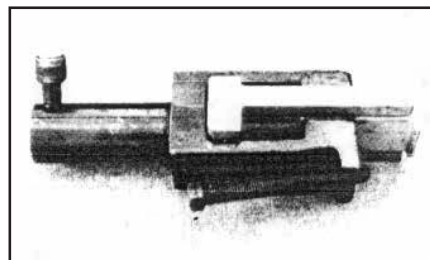

4. Bead Breaker, used for loosening tires from bead seats when the rim has prying slots.

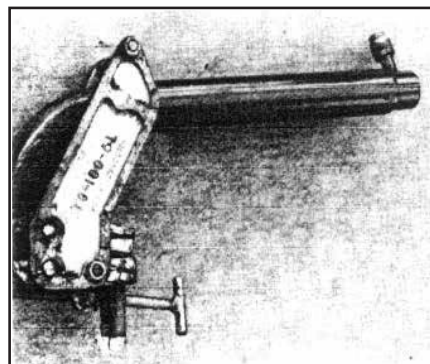

5. Bead Breaker, used for loosening tire from bead seats when the rim has no prying slots.

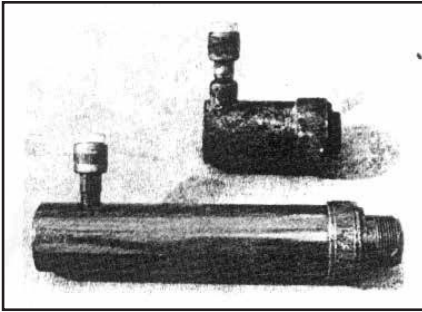

6. Top: 4" ram Hydraulic Demounting tool. Bottom: 6"-8" ram Hydraulic Demounting tool.

Rams apply pressure to the inside bead flange when removing tires from 15° tapered rims.

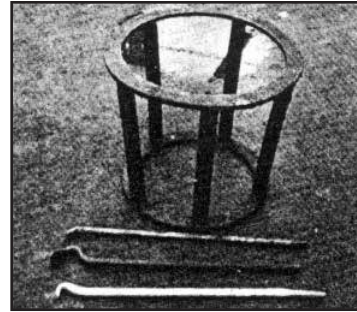

9. Mounting stand, used when mounting tires on rims that have been removed from a vehicle.

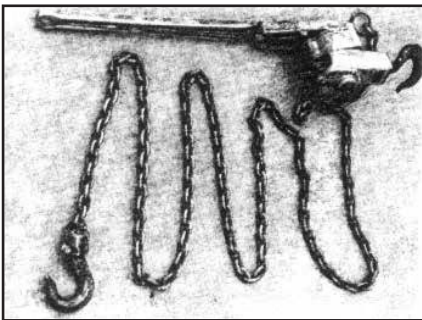

7. Coffin hoist (1/2 ton capacity). This tool expands the bead on tapered bead seats, so that a tubeless tire will take air.



10. A service truck with a hydraulic hoist is essential to installing and removing today's heavy off-the-road tires.

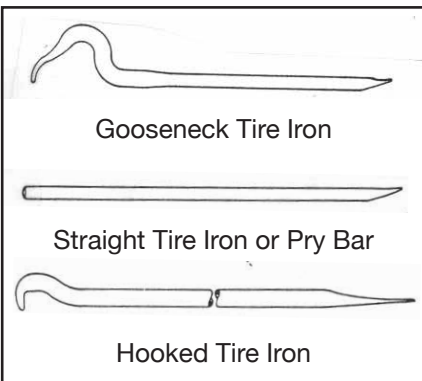

8. These tire irons are used to pry apart wheel components.

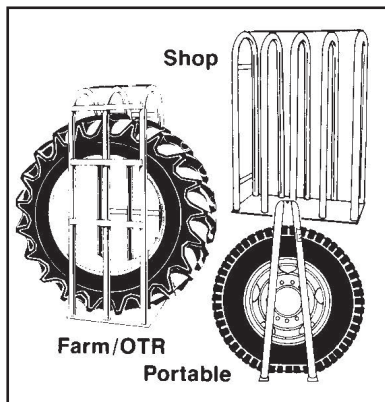

11. A cage of restraining device in which to place the wheel/tire assembly while inflating.

Safety Information

Identification/Terminology

Single-Piece Rims

1. Rim Size (Nominal Bead Seat Diameter)
2. Rim Width
3. Rim Inside Dia.
4. Bead Seat Area
5. Flange
6. Flange Height
7. Valve Hole (Location and size can vary)

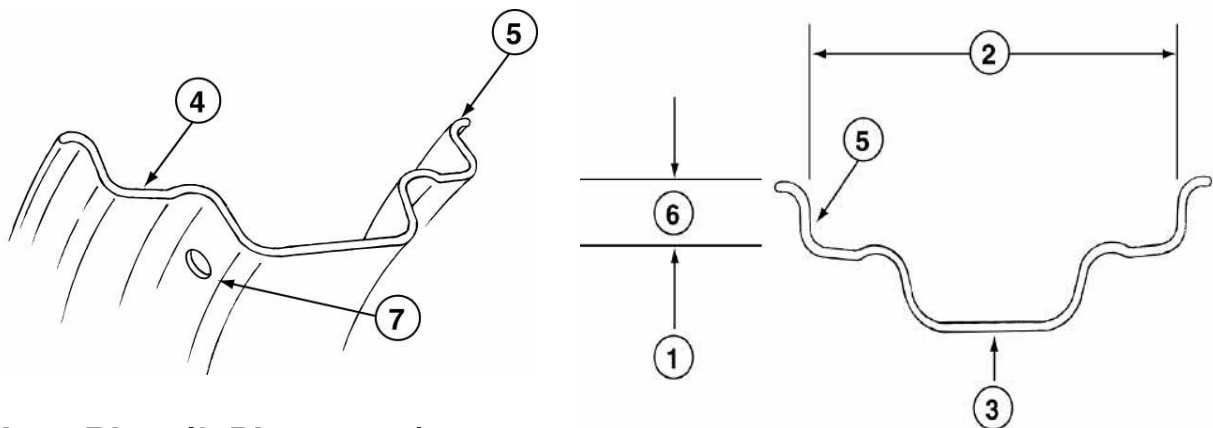

Multi-Piece Rims (3-Piece Type)

1. Rim Size (Nominal Bead Seat Diameter)
2. Rim Width
3. Rim Inside Dia.
4. Bead Seat Area
5. Flange-Fixed
6. Flange Height
7. Valve Hole (Location and size can vary)
8. Flange-Removable (Side Ring)
9. Lock Ring
10. O-Ring (For tubeless application only)
11. 28° Mounting Bevel (utilized for demountable application only)
12. Rim Stop Plate (Used for demountable application only; size, shape and location can vary.)
13. O-Ring Groove
14. Lock Ring Groove
15. Gutter portion of rim

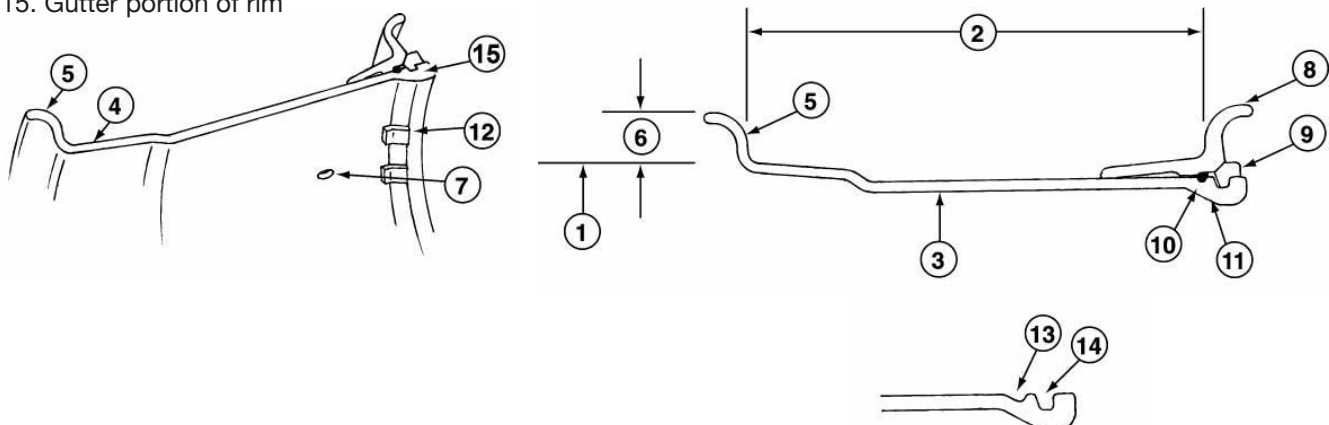

Identification/Terminology

Multi-Piece Rims (5-Piece Type)

1. Rim Size (Bead Seat Diameter)
 2. Rim Width
 3. Rim Inside Dia.
 4. Back Flange Portion of Rim Base
 5. Center Band Portion of Rim Base
 6. Gutter Band Portion of Rim Base
 7. Rim Base (Entire Shaded Area)
 8. Bead Seat Band (Removable, Gutter Side only)
 9. Lock Ring
 10. O-Ring
 11. Flange, Inner (Removable)
 12. Flange, Outer (Removable) *Note: Inner and Outer Flanges are identical
 13. 28° Mounting Bevel (Utilized for demountable application only)
 14. Valve Hole (Location, size and configuration can vary)
 15. Knurl (Located on Back Flange Portion of Rim Base and Bead Seat Band tire mating surfaces)
 16. O-Ring Groove
 17. Lock Ring Groove (size and shape can vary depending on style of lock ring)
- Not Shown: Pry Bar Pocket (continuous gap entire circumference on some items)

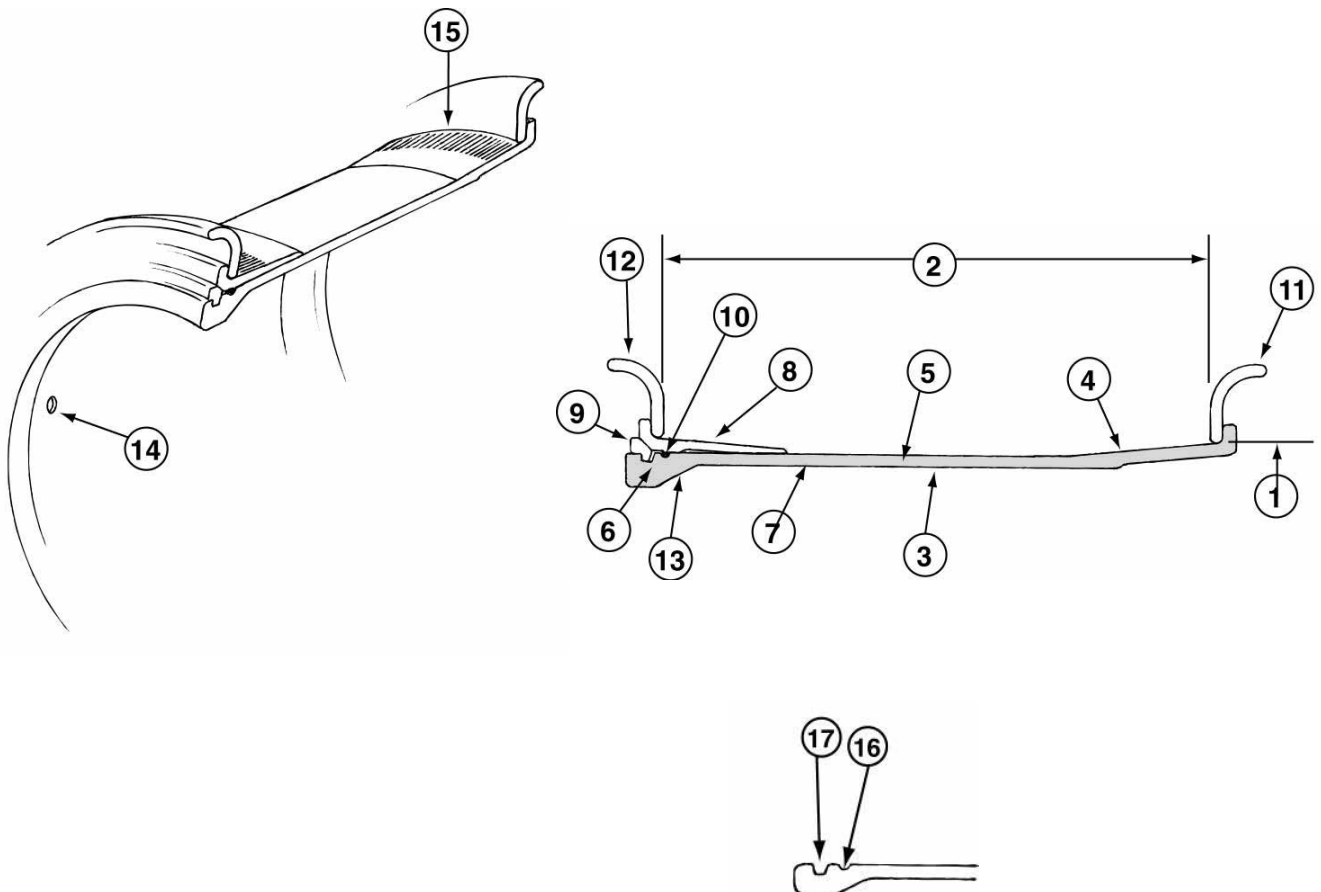

Safety Information

Identification/Terminology

Multi-Piece Rims (5-Piece Type)

Crimped on Style Driver

1. Lock Ring
2. Crimped on driver
3. Notch in gutter portion of rim
4. Notch in bead seat band

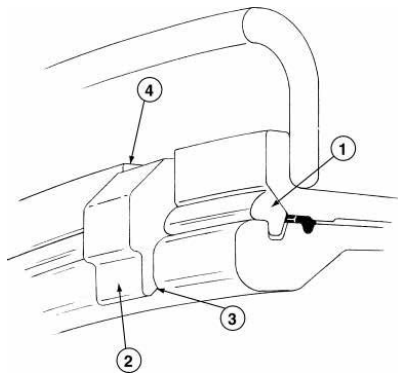

Loose Style Driver

1. Driver Pocket (Welded on gutter portion of rim base)
2. Driver Pocket (Welded on bead seat band)
3. Driver Key* *Note: See page S:24 for Driver Key Styles.

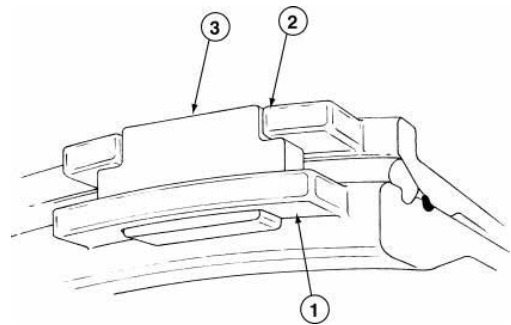

Demountable Type Rims

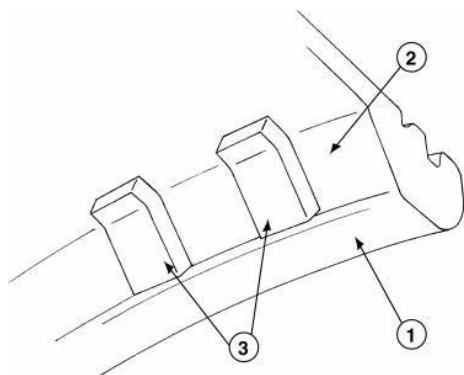

1. Gutter Portion of Rim Base
2. 28° Mounting Bevel
3. Rim Stop Plates (location, style and size can vary)

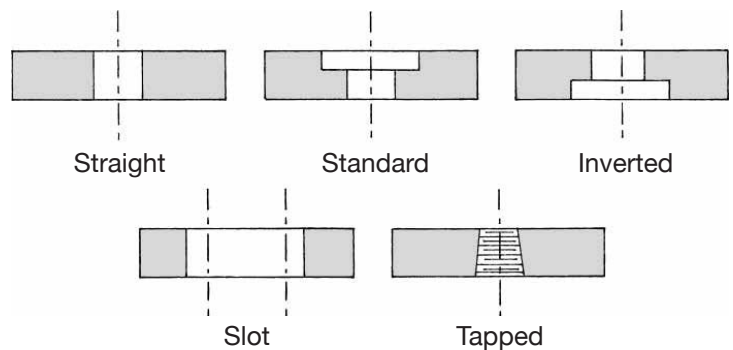

Valve Hole Styles



Titan “W” Series Rims are not interchangeable with other types

-  If you have any doubt about the correct, safe method of performing any step in the demounting, mounting, or inflating process STOP! Seek assistance from a qualified person.
-  Rim and Wheel Components are not always interchangeable check part numbers carefully before assembling.
-  Titan’s “W” SERIES LOCK RINGS ARE NOT INTERCHANGEABLE WITH OTHER TYPES, it is vitally important that you must check part numbers carefully before rim assembly. Following is a summary of the changes.

“W” Style Lock Ring

A “W” appears after the part number, which is stamped on the 45 degree face near the lock ring split (e.g. LR49W for a 49” rim), see illustration below.

A circumferential groove gives the ring a unique appearance. This lock ring can only be used with the new “W” style gutters.

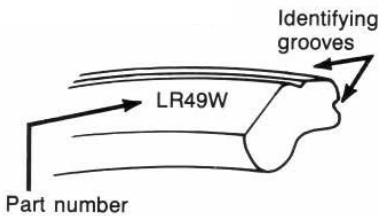

“W” Style Rim Base

There are two types of rim bases, the old version contains a “T” in the part number, whereas the new style contains a “W.” A “W” style rim base must be matched only with a “W” style lock ring.

OLD	NEW
B1735HTHGD	B1735RWHGD
B3239HTEL	B3239RWEL

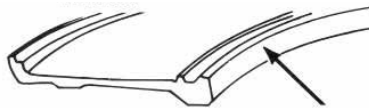

The faces of the “W” style rim base carries a caution stamping advising the user of the proper lock ring part number.

Bead Seat Bands

There are two types of bead seat bands, the old version contains an “H” in the part number, whereas the new style contains an “R.” These bead seat bands are interchangeable.

The R and H Bead Seats are interchangeable.

OLD	NEW
BB49HTG	BB49RTG BB39HTL
BB28RTL	

 DO NOT MISMATCH LOCK RINGS AND RIM BASES

Correct Assembly:

“W” style lock ring with grooves assembled with “W” style rim base.

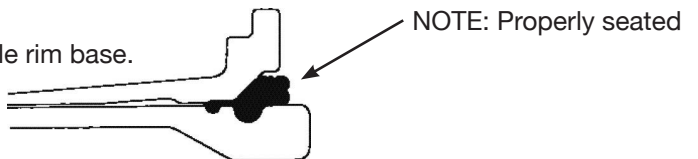

Incorrect Assembly:

“W” lock ring with old rim base. Note poor fit and gap between lock ring and gutter. DO NOT USE. REASSEMBLE USING PROPER COMPONENTS.

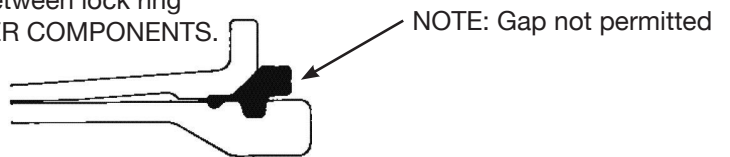

Incorrect Assembly:

“W” lock ring with old rim base. Note poor fit and gap between lock ring and gutter. DO NOT USE. REASSEMBLE USING PROPER COMPONENTS.

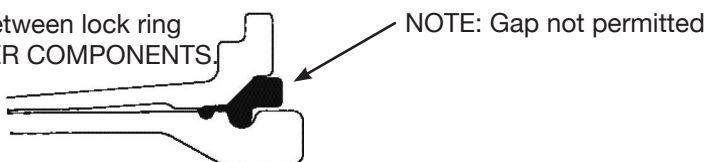

Safety Information

Outboard Driver Keys

Instructions

⚠ If you have any doubt about the correct, safe method of performing any step in the demounting, mounting, or inflating process STOP! Seek assistance from a qualified person.

Outboard Driver Keys

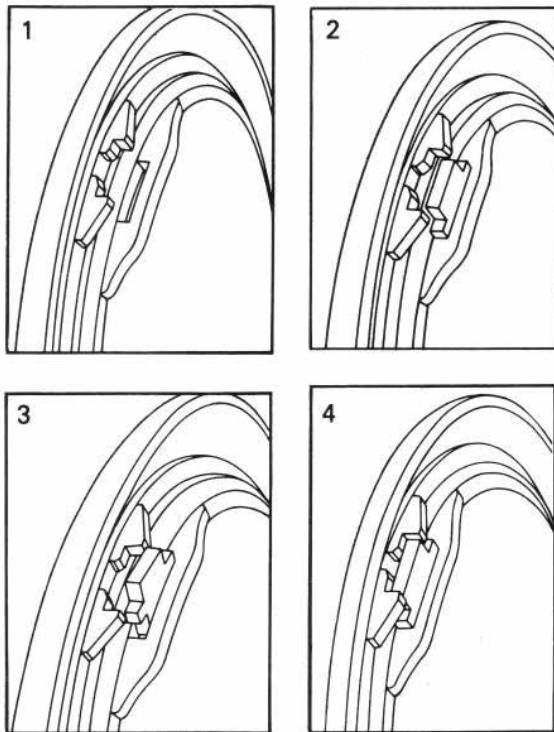

1. Align driver pockets in bead seat band and base as shown.

2. Inset driving key into driver pocket on base. 3. Make cer-

tain that all parts are properly aligned, as shown, before inflation.

4. When properly aligned, the bead seat band and pocket will move out and lock the driver key during inflation.

Outboard drivers are on those rims used in high torque and/or low inflation pressure applications, preventing circumferential movement of the rim components. Rim assemblies with an "M" or "L" near the end of the style designation (part number) are so equipped.

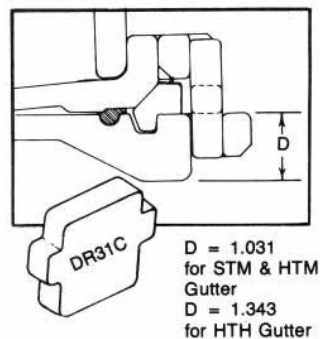

The DR31C driver key is used on rim bases with 1.0" and 1.3" approximate thickness gutter sections; basic styles STM, HTM, HTHM and HTHL.

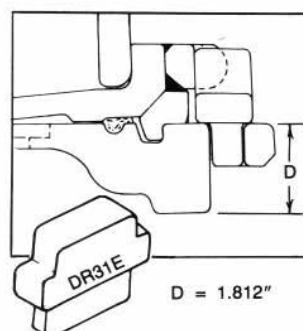

The DR31E driver key is used on rim bases with the 1.8" approximate thickness gutter section; basic style HTEL.

Demounting Tires from Titan Assemblies

3-Piece Rim Assemblies

Tools Required: One (1) straight tire iron tool; Two (2) gooseneck tire iron tools; Rubber lubricant; Rubber, lead, plastic or brass-faced mallet and valve core removal tool, wire.

! The task of servicing tires and wheels can be extremely dangerous and should be performed by trained personnel only, using the correct tools and following specific procedures. If you have any doubt about the correct, safe method of performing any step in the demounting, mounting, or inflating process STOP! Seek assistance from a qualified person.

! Always completely deflate tire (both tires of a dual assembly) by removing valve core(s) from valve(s) before attempting any demounting operation. Check the valve stem by running a piece of wire through the stem to make sure it is not plugged.

! Stand clear of trajectory danger zone when deflating (p. S:5 & S:17).



1. After complete deflation, place the assembly on the floor (on blocks with loose side flange side up).

2. Drive the goose-necked end of two gooseneck tire iron tools between the tire and side flange about 5 inches apart.



3. Pry both tools down and out as shown. Leave one tool in position and place the second about 5 inches beyond. Repeat in successive steps until the tire bead is completely unseated.

! Never release your grip on the tire irons, as they may spring back.



4. After the tire bead is unseated, stand on side flange and tire sidewall to depress the side flange down along the rim base. Pry the lock ring loose, starting at the split then remove the lock ring.

! Keep fingers clear of pinch points.



5. Hold the side flange down with hooked end of gooseneck tire iron to remove the "O" ring from ring groove. It is a good idea to cut and discard the "O" ring and replace it with a new "O" ring.

! Keep fingers clear of pinch points.



6. Remove the side flange.

7. Turn tire and rim over and unseat second bead by inserting both gooseneck tire iron tools between tire and fixed rim flange as in step 3. Repeat steps 2 and 3 until the tire bead is completely broken loose from the rim on the fixed flange side. Lift rim base out of tire.

! Do not release your grip on the tire irons, as they may spring back.

! Keep fingers clear of pinch points.

Safety Information

Mounting Tires on Titan Assemblies

3-Piece Rim Assemblies

Tools Required: One (1) straight tire iron tool; Two (2) gooseneck tire iron tools; Rubber lubricant; Rubber, lead, plastic or brass-faced mallet and safety cage.

! The task of servicing tires and wheels can be extremely dangerous and should be performed by trained personnel only, using the correct tools and following specific procedures. If you have any doubt about the correct, safe method of performing any step in the demounting, mounting, or inflating process STOP! Seek assistance from a qualified person.

1. Clean the rim base and all components thoroughly with a wire brush to facilitate inspection, maintenance and mounting.

! Clean all dirt and rust from inter-locking faces of multi-piece rim components particularly the gutter sections which hold the lock ring and "O" ring in place. Failure to adequately clean all components will inhibit efforts to inspect, maintain, and reassemble the tire and wheel correctly.

2. Inspect rim base and wheel components for cracks, wear, corrosion and damage.

! Parts that are cracked, worn, pitted with corrosion, or damaged must be destroyed and replaced with good parts.

! In situations where part condition is suspect or in doubt destroy the part, discard and replace with good part.

! Do not, under any circumstances, attempt to re-work, weld, heat, or braze any rim base or wheel components.

! Verify that the replacement parts are the correct size and type and manufacturer for the wheel being assembled.

3. After the rim and wheel component inspection is complete, and rim base and wheel components are verified to be in good usable condition, repaint all bare metal with a rust inhibitor to retard detrimental effects of corrosion.

! Follow procedures and safety precautions of the paint manufacturer.

4. Inspect the tire for wear, cracks, tears, punctures and other damage.

! Tires with excessive or uneven wear, cracks, tears, punctures, blisters or other damage may explode during inflation or service and tire should be destroyed and replaced with good tire of correct size, type and manufacturer for assembly, machine, and application.

! If in doubt of the condition of the rim base, wheel components, or tire - STOP - contact the manufacturer or distributor for assistance.

Make sure parts are clean, repainted if necessary and have been inspected for damage and cracks before proceeding with mounting.

! Parts that are cracked, worn, pitted with corrosion, or damaged must be rendered unusable, discarded and replaced with good parts.

5. Install valve spud on rim.

! Follow valve spud manufacturer's recommendations and installation instructions.

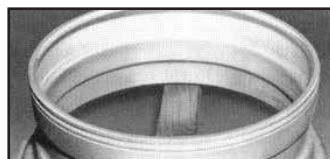

6. Place rim base on blocks with fixed flange side down. Lubricate both bead seats of the tire with vegetable base lubricant. Place tire over rim base.

! Never use petroleum-based lubricant; use vegetable-based lubricant only.



7. Place side flange over rim base and push straight down with hands as far as possible. Make sure side flange does not bind on rim base.

! First, double check to make sure correct parts are being assembled, then proceed.

! Keep fingers clear of pinch points.

Mounting Tires on Titan Assemblies

3-Piece Rim Assemblies

! The task of servicing tires and wheels can be extremely dangerous and should be performed by trained personnel only, using the correct tools and following specific procedures. If you have any doubt about the correct, safe method of performing any step in the demounting, mounting, or inflating process STOP! Seek assistance from a qualified person.



8. Lubricate a new rubber "O" ring. Place "O" ring in groove on one side and stretch "O" ring snapping it into place rather than rolling it into place. Then lubricate the entire "O" ring area. (NOTE: It may be necessary to hold the side flange down with the flat end of the gooseneck tire iron tool in order to expose the "O" ring groove.)

! Keep fingers clear of pinch points.

! Never use petroleum-based lubricant; use vegetable-based lubricant only.



9. Stand on side flange to position it below both grooves in the rim base and snap lock ring into lock ring (upper) groove. Be certain the lock ring is installed with the correct side facing the operator as illustrated on page S:23.

10. Check components to make sure that parts are correctly assembled. (NOTE: Lock ring should be fully seated in gutter.)

! Lock Ring must be properly seated in gutter, see p. S:23.

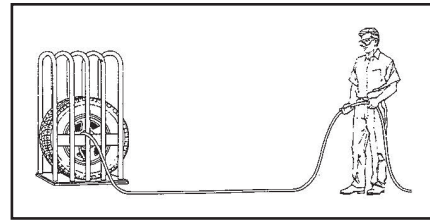

11. Place rim and tire in a safety cage during tire inflation. Stand to the side of the tire during inflation as illustrated. Inflate to approximately 3 psi and again check for proper engagement of all components. If assembly is correct, continue to inflate to recommended pressure.

! Stand clear of potential trajectory danger zone (see diagram). Refer to page S:5 and S:17.

NOTE: It is advisable to use a clip-on chuck with an in-line pressure gauge and enough air line hose to permit the person inflating the tire to stand clear of the potential trajectory danger zone.

! If assembly is incorrect STOP-DEFLATE-CORRECT THE ASSEMBLY-AND REPEAT PROCEDURE.

! Never attempt to align or seat side flange, lock ring or other components by inflation, hammering, welding, heating or brazing.

NOTE: A filter on the air inflation equipment to remove moisture from the air line prevents corrosion. Check the filter periodically to be sure it's functioning properly.

! Never inflate beyond manufacturer's recommended tire pressure.

Safety Information

Demounting Tires on Titan Assemblies

5-Piece Rim Assemblies

Tools Required: hydraulic demounting tool and two straight tire irons, screwdriver, piece of wire.

⚠ The task of servicing tires and wheels can be extremely dangerous and should be performed by trained personnel only, using the correct tools and following specific procedures. If you have any doubt about the correct, safe method of performing any step in the demounting, mounting, or inflating process STOP! Seek assistance from a qualified person.

⚠ Always completely deflate tire (both tires of a dual assembly) by removing valve core(s) from valve(s) before attempting any demounting operation. Check the valve stem by running a piece of wire through the stem to make sure it is not plugged. Remove driving key if present. See page S:24.

1. Place the assembly gutter side up on blocks.

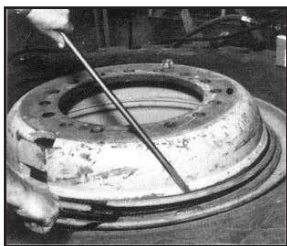

2. Remove the lock ring, using two tire irons (NOTE: If this is not possible, the tire bead may be unseated as shown in step 4 with the lock ring and "O" ring in place. However, these items must be removed before removal of bead seat bands and flanges in step 7).

⚠ Keep fingers clear of pinch points.

⚠ Do not release your grip on the tire irons, as they may spring back.

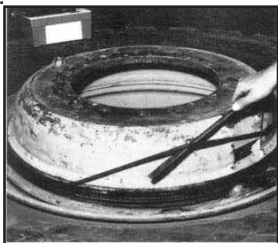

3. Remove the "O" ring by prying the bead seat band back and inserting a pry bar or screwdriver under the "O" ring and pulling it from the groove. It is good practice to cut and discard the "O" ring and replace with a new "O" ring.

⚠ Keep fingers clear of pinch points.

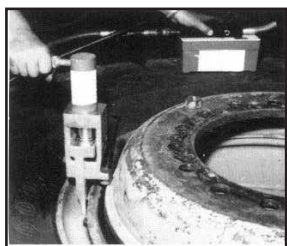

4. Place hook of the hydraulic demounting tool into one of the pry bar pockets. A continuous lip is provided on some bases. Adjust the ram adjusting screw to enable the tool to remain vertical when under pressure. In some cases, the pressure foot may have to be removed to ensure a good hold. Activate the hydraulic pump and apply pressure. If necessary, release pressure and readjust the ram adjusting screw. Depress flange about 1/2"-3/4" and place a nut or similar object between the flange and the lip of the bead seat band by laying it on the rim flange and sliding it into position with a screwdriver.

⚠ Keep fingers clear of pinch points.

⚠ Always stand to one side of the tool and hold it with one hand. This allows control should the tool not seat properly and fly off.

5. Release the pressure and move about 2 feet around the rim or to the next pocket for the second bite. Continue the procedure until the tire bead is unseated.

Do not use tool in the vicinity of the butt weld area of the bead seat band, the flanges, or rim base.

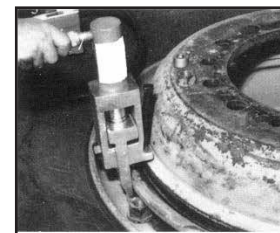

6. Remove bead seat band using hoist or pry bars.

⚠ fingers clear of pinch points.

7. Remove outer flange (ref. p. S:21) using a hoist or pry bars.

⚠ Always stand clear when using mechanical lifting devices.

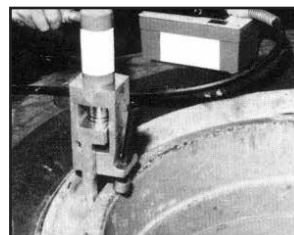

8. Turn assembly over and repeat tire bead unseating procedure on the back side. (Steps 4 & 5)

9. Lift rim base from tire using hoist.

10. Remove inner flange. (ref. p. S:21)



In some cases it may be advantageous to use a more powerful hydraulic demounting tool with a longer stroke. However, caution must be used to avoid bending the flange or breaking the butt weld. Follow procedure outlined

in step 4.

⚠ If the flange or butt weld are damaged, destroy the parts, discard, and replace with good parts.

Mounting Tires on Titan Assemblies

5-Piece Rim Assemblies

Tools Required: Rubber, lead, plastic or brass-faced mallet; rubber lubricant, mounting machine to depress beads, if necessary and safety cage.

! The task of servicing tires and wheels can be extremely dangerous and should be performed by trained personnel only, using the correct tools and following specific procedures. If you have any doubt about the correct, safe method of performing any step in the demounting, mounting or inflating process STOP! Seek assistance from a qualified person.



1. Before mounting, always clean all rim components, removing rust and dirt, especially from the lock ring groove and "O" ring groove to insure proper seating and seal. Inspect parts for damage. Replace all cracked, badly worn, damaged and severely rusted components; paint or coat all parts with a rust inhibitor. Double check to be sure correct parts are being assembled. Also inspect the tire for foreign matter.

! Tires with excessive or uneven wear, cracks, tears, punctures, blisters or other damage could explode during inflation or service. Discard the tire and replace with good tire of correct size, type and manufacturer for assembly, machine and application.

! Follow procedures and safety precautions of the paint manufacturer.

! Parts that are damaged or suspected of being damaged must be destroyed, discarded and replaced with good parts.

! Do not attempt to rework, weld, heat or braze any rim base or wheel components.

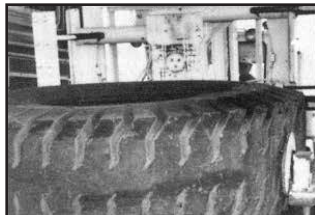

2. Place rim base on blocks (4" to 6" high) on floor, gutter side up. Place inner flange (ref. p. S:21) on rim base, lubricate tire beads with vegetable lubricant. Place tire on rim using tire handler or hoist with sling.

! Never use petroleum-based lubricant; use vegetable based lubricant only.

3. Depress the tire so that the lower tire bead is driven onto the back 5° Bead Seat taper of the rim. This will expose more of the gutter at the upper side of the rim base to facilitate assembly.

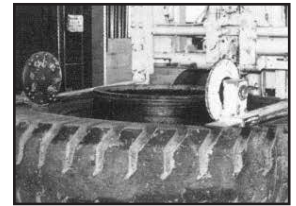

4. Place the outer flange (ref. p. S:21) over the rim base on the tire.

! Keep fingers clear of pinch points.

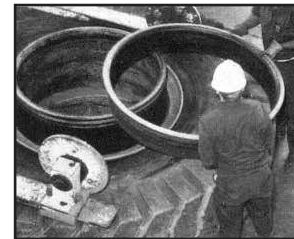

5. Place the bead seat band on the rim base. If present, driver pockets must be aligned. See page S:24. Due to limited clearance between bead seats and rim base, bead seat band will bind if cocked slightly. Band should slide freely over base.

! DO NOT HAMMER BEAD SEAT BAND INTO PLACE!

! If necessary, remove and re-install, or use rubber-, lead-, plastic- or brass-faced mallet to tap, lightly upward on the bead seat band in order to get it to seat properly.



6. Place a new, lubricated "O" ring into the "O" ring groove, then lubricate the entire "O" ring area with an approved vegetable-base lubricant. Snap "O" ring into place by placing in groove on one side, stretching like rubber band and seating on opposite side.

! Never use petroleum-based lubricant; use vegetable based lubricant only.

! Keep fingers clear of pinch points.

Safety Information

Mounting Tires on Titan Assemblies

5-Piece Rim Assemblies

! The task of servicing tires and wheels can be extremely dangerous and should be performed by trained personnel only, using the correct tools and following specific procedures. If you have any doubt about the correct, safe method of performing any step in the demounting, mounting, or inflating process STOP! Seek assistance from a qualified person.



7. Start the lock ring in the lock ring groove and push or walk it into place.

! Keep fingers clear of pinch points.



8. Insert drive key as required in pockets. See page S:24. Never

! exceed the manufacturer's recommended inflation pressure.

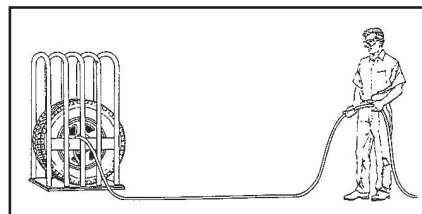

9. Place rim and tire in a safety cage during tire inflation. Stand to the side of the tire during inflation as illustrated. Inflate to approximately 3 psi and again check for proper engagement of all components. If assembly is correct, continue to inflate to recommended pressure.

! Stand clear of potential trajectory danger zone (see diagram page S:5 & S:17).

NOTE: It is advisable to use a clip-on chuck with an in-line pressure gauge and enough air line hose to permit the person inflating the tire to stand clear of the potential trajectory danger zone.

! If assembly is incorrect, STOP-DEFLATE-CORRECT THE ASSEMBLY-AND REPEAT PROCEDURE.

! Never attempt to seat rings or other components or correct components alignment by hammering, welding, heating or brazing while tire is inflated, partially inflated or deflated.

On-Vehicle Demounting of Tires from Titan 5-Piece Rim Assemblies

! Due to the variety of vehicle/equipment configurations and the range of conditions and situations under which on-vehicle demounting (wheel/tire assembly still attached to vehicle or equipment) can occur, proper procedures for blocking, jacking, cribbing of the vehicle/equipment must be done in accordance with the manufacturer's operator's manual, maintenance manual or the information as provided by the vehicle/equipment manufacturer.

Tools required: Hydraulic Demounting Tool; Hooked Tire Iron; Pry Bar; lifting device or boom truck; and valve core removal tool; jack, cribbing, blocking or other items as needed to jack and block the vehicle/equipment per the manufacturer's instructions.

! The task of servicing tires and wheels can be extremely dangerous and should be performed by trained personnel only, using the correct tools and following specific procedures. If you have any doubt about the correct, safe method of performing any step in the demounting, mounting or inflating process STOP! Seek assistance from a qualified person.

1. Jack, crib and block the vehicle/equipment per the manufacturer's instructions.

! Jacking, cribbing and blocking a vehicle/equipment can be hazardous. You must refer to the manufacturer's operator's or maintenance manual for proper procedures.

! Always completely deflate tire (both tires of a dual assembly) by removing valve core(s) from valve(s) before attempting any demounting operation. Check the valve stem by running a piece of wire through the stem to make sure it is not plugged. Remove driving key if present.



2. Place the hook of the hydraulic demounting tool into one of the pry bar pockets. A continuous lip is provided on some bases. Adjust the ram adjusting screw to enable the tool to be perpendicular to the wheel when under pressure.

! Always stand to one side of the tool and hold it with one hand. This allows control should the tool not seat properly and fly off.

3. Apply pressure and depress the flange about 3/4." If necessary release the pressure to readjust the tool. Place the end of a hooked tire iron between the flange and the lip of the bead seat band and release the pressure. Now place the hook of the hydraulic demounting tool under the lip of the bead seat band and continue the procedure around the rim; then slowly apply pressure until the tire bead is COMPLETELY unseated.

4. Remove driving key if present. See page S:24.

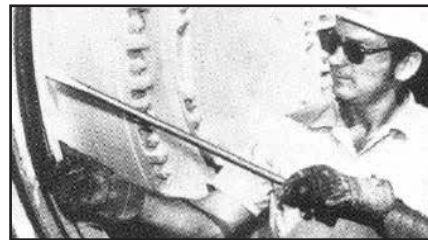

5. Remove the lock ring with a pry bar, starting near the split and working around the ring.

! Never release grip on pry bars or tire irons when working on wheel-tire assemblies, as they may spring back.

! Keep fingers clear of pinch points.



6. Insert the tip of a hooked tire iron under the "O" ring and pull it from the groove. It is good practice to destroy the old "O" ring to insure that a new "O" ring will be used.

Safety Information

On-Vehicle Demounting of Tires

from Titan 5-Piece Rim Assemblies The

! task of servicing tires and wheels can be extremely dangerous and should be performed by trained personnel only, using the correct tools and following specific procedures. If you have any doubt about the correct, safe method of performing any step in the demounting, mounting, or inflating process STOP! Seek assistance from a qualified person.

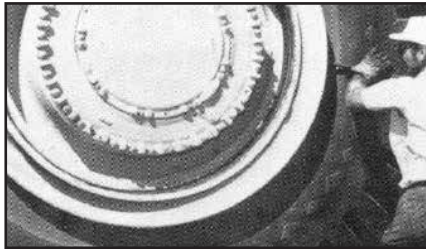

7. Use a hooked tire iron under the flange to pry the bead seat band loose, with assistance of lifting device, carefully lower the bead seat band to the ground and roll it out of the way.

! Use mechanical lifting device to avoid injury.



8. With assistance or a lifting device, remove the outer flange, then carefully lower it to the ground and roll it out of the way.

! Use mechanical lifting device to avoid injury.



9. To unseat the inner tire bead, use either the hydraulic demounting tool as used on the outer bead or a shorty ram between the frame of the vehicle and the back flange, as shown.



10. Remove the tire using a boom truck and sling or a tire handler. Remove the inner flange to complete the disassembly.

! When using a sling, stand clear.

On-Vehicle Mounting of Tires on Titan 5-Piece Rim Assemblies

! Due to the variety of vehicle/equipment configurations and the range of conditions and situations under which on-vehicle demounting (wheel/tire assembly still attached to vehicle or equipment) can occur, proper procedures for blocking, jacking, cribbing of the vehicle/equipment must be done in accordance with the manufacturer's operator's manual, maintenance manual or the information as provided by the vehicle/equipment manufacturer.

Tools Required: Lifting device or boom truck; jack, cribbing, blocking or other items as needed to jack and block the vehicle/equipment per the manufacturer's instructions.

! The task of servicing tires and wheels can be extremely dangerous and should be performed by trained personnel only, using the correct tools and following specific procedures. If you have any doubt about the correct, safe method of performing any step in the demounting, mounting, or inflating process STOP! Seek assistance from a qualified person.

1. Before mounting, always clean all rim components, removing rust and dirt, especially from the lock ring groove and "O" ring groove to insure proper seating and seal. Inspect parts for damage. Replace all cracked, badly worn, damaged and severely rusted components; paint or coat all parts with a rust inhibitor. Double check to be sure correct parts are being assembled. Also inspect the tire for foreign matter.

! Follow procedures and safety precautions of the paint manufacturer.

! Tires with excessive or uneven wear, cracks, tears, punctures, blisters or other damage may explode during inflation or service. If tire failure potential is suspected, discard the tire and replace with good tire of correct size, type and manufacture for assembly, machine and application.

! Parts that are cracked, worn, pitted with corrosion, or damaged must be discarded and replaced with good parts.

! Do not attempt to rework, weld, heat or braze any rim base or wheel components.

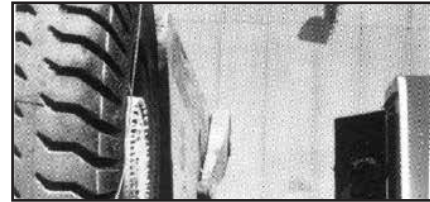

2. Place the inner flange on the rim base, lubricate the tire beads with a vegetable-based lubricant, and position the tire on the rim base using a boom truck or handler.

! Never use petroleum-based lubricant; use vegetable-based lubricant only.

! Stand clear of lifting device.

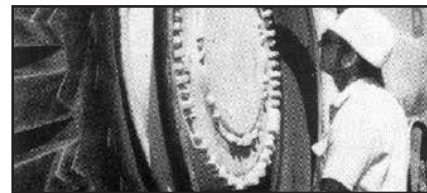

3. Position the outer flange on the rim base with the help of the boom.

! Stand clear of lifting device.

! Keep fingers clear of pinch points.

4. Place the bead seat band on the rim base with the help of the boom.

Be sure driver pocket on bead seat band lines up with pocket on rim base.



! Stand clear of lifting device. Keep

! fingers clear of pinch points.



5. Using the boom to hold the rim components back out of the way, insert a new, lubricated "O" ring into the "O" ring groove area with an approved vegetable-base lubricant. Snap "O" ring into place by placing in groove on one side stretching like a rubber band and seating on opposite side.

Safety Information

On-Vehicle Mounting of Tires

on Titan 5-Piece Rim Assemblies

! The task of servicing tires and wheels can be extremely dangerous and should be performed by trained personnel only, using the correct tools and following specific procedures. If you have any doubt about the correct, safe method of performing any step in the demounting, mounting, or inflating process STOP! Seek assistance from a qualified person.



6. Work the lock ring into the lock ring groove.

! Keep fingers clear of pinch points.

7. Check components (lock rings, bead seat and flanges) to make sure that parts are correctly assembled. (NOTE: lock rings should be fully seated in gutter around the circumference. See page S:22.) Insert driver key as required, see page S:23.

Use a clip-on chuck with an in-line pressure gauge and enough air line hose to permit the person inflating the tire to stand clear of the potential trajectory danger zone. (See p. S:5 & S:17) Stand to the side of the tire during inflation. Inflate to approximately 3 psi and again check for proper engagement of all components. If assembly is correct, continue to inflate to recommended pressure.

! Stand clear of potential trajectory danger zone (see p. S:5 & S:17 illustration).

! If assembly is incorrect, STOP-DEFLATE-CORRECT THE ASSEMBLY-AND REPEAT PROCEDURE.

! Never attempt to inflate an assembly if components are not properly aligned. Never attempt to seat rings or other components or correct components alignment by hammering, welding, heating or brazing while tire is inflated, partially inflated or deflated.

NOTE: A filter on the air inflation equipment to remove moisture from the air line prevents a lot of corrosion. Check the filter periodically to be sure it's functioning properly.

! Never inflate beyond manufacturer's recommended tire pressure.

