



KUMHO TIRE
PRODUCT
DATA GUIDE
MEDIUM COMMERCIAL TRUCK

TECHNICAL DATA 04

- Kumho Tire Naming System 04
- Technical Specification Chart 06
- SmartWay Certification 08
- Application Chart 09
- Performance Analysis 10
- Structure Optimization 12
- Rubber Compound Technology 13
- Sidewall Information 14
- Tire Dimensions 15

MEDIUM COMMERCIAL TRUCK 16

STEER



KLS02e 16
STEER



KRS02 [e] 17
STEER



KRS03 18
STEER

DRIVE



KLD02 [e] 19
DRIVE



KLD11e 20
DRIVE



KRD01 21
DRIVE



KRD03 22
DRIVE



KRD16 23
DRIVE



KRD50 24
DRIVE



KMD41 25
DRIVE
MIXED SERVICE

KUMHO TIRE

TRAILER



KLT12e 26
TRAILER



KRT03a 27
TRAILER



KRT12 28
TRAILER

ALL-POSITION



KRA12 29
ALL-POSITION



KMA01 30
ALL-POSITION
MIXED SERVICE



KMA02 31
ALL-POSITION
MIXED SERVICE



KMA12 32
ALL-POSITION
MIXED SERVICE

WARRANTY POLICIES 34

- Warranty Coverage **34**
 - What is warranted and who is eligible under this warranty
 - What is covered by the warranty and how long
 - What is not covered by the warranty
- Owner's Obligation – Your Responsibilities in Order to Maintain Your Warranties **35**
 - Owner's Obligation
 - Other Rights
 - New Tire D.O.T. Registration
- Casing Credit **35**
- Replacement Warranty **35**
- Safety Warnings **36**
- Adjustment Credit Percentage Chart **37**

MEDIUM COMMERCIAL TRUCK

KUMHO TIRE NAMING SYSTEM

Kumho Tire offers a wide selection of medium commercial tires for regional and local delivery trucks, long distance tankers and trailers, dump trucks, cement mixers and buses. Conventional and low profile designs and standard, deep, extra deep and shallow tread depths are available to match your exact application needs.

K	L	D	01
BRAND	APPLICATION	POSITION	CODE
K KUMHO	L LINE HAUL	S STEER AXLE USE	01
	R REGIONAL	D DRIVE AXLE USE	02
	C P&D (CITY TRANSIT)	T TRAILER USE	03
	M MIXED SERVICE	A ALL-POSITION	04
	F OFF-ROAD		THRU 99
	W WINTER		





TECHNICAL SPECIFICATION CHART

TREAD DEPTH/LOAD RANGE

		10R22.5	11R22.5	11R24.5	12R22.5	295/75R22.5	285/75R24.5	255/70R22.5	315/80R22.5
Steer	KLS02e		14/G 16/H	14/G		14/G 16/H	14/G		
	KRS02[e]	14/G	16/H	16/H	16/H	14/G 16/H	14/G	16/H	
	KRS03								20/L
Drive	KLD02[e]		14/G	14/G		14/G	14/G		
	KLD11e		14/G	14/G		14/G	14/G		
	KRD01		16/H	16/H		14/G	14/G		
	KRD03		16/H	16/H					
	KRD16								
	KRD50								
	KMD41		16/H	16/H					
Trailer	KLT12e		14/G	14/G		14/G	14/G		
	KRT03a							16/H	
	KRT12		14/G	14/G		14/G			
All-Position	KRA12								
	KMA01		16/H	16/H					20/L
	KMA02								
	KMA12								



215/75R17.5	235/75R17.5	225/70R19.5	245/70R19.5	275/70R22.5	385/65R22.5	425/65R22.5	445/65R22.5	750R16
								14/G
		14/G	14/G	16/H				
		14/G						
			16/H					
16/H	18/J							
					18/J	20/L		
					18/J	20/L		
						20/L	20/L	

SMARTWAY CERTIFICATION

SMARTWAY TRANSPORT PARTNERSHIP

The SmartWay Transport Partnership is a collaboration between freight shippers, carriers, and logistics companies to voluntarily achieve improved fuel efficiency and reduced emissions from freight transport. The program is administered by the United States Environmental Protection Agency (USEPA) and is currently housed with the USEPA's Office of Transportation and Air Quality (OTAQ).

GOALS OF THE SMARTWAY

The SmartWay Transport Partnership is likely to have increasing appeal in the coming years as fuel prices rise and as the prospect of global warming influences businesses and individuals to reassess their environmental footprint.









By 2012, the SmartWay Transport Partnership aims to save between 3.3 and 6.6 billion gallons of diesel fuel per year, which translates to eliminating between 33-66 million metric tons of carbon dioxide emissions and up to 200,000 tons of nitrous oxide emissions per year.

The Partnership also aims to reduce large amounts of particulate matter (PM). The SmartWay Partnership is committed to helping freight shippers and carriers discover ways to improve the efficiency of their supply chain and achieve superior environmental performance.



TECHNICAL DATA

APPLICATION CHART

	LINE HAUL Interstate Highway	REGIONAL Highway & City	MIXED SERVICE Mixed Conditions	WIDEBASE Mixed Conditions
STEER & ALL-POSITION	 KLS02e	 KRS02[e] KRS03	 KMA01	 KRA12 KMA02 KMA12
DRIVE	 KLD02[e] KLD11e	 KR001 KR003 KR016 KR050	 KMD41	
TRAILER	 KLT12e	 KRT03a KRT12		

PRODUCT POSITIONING MAP

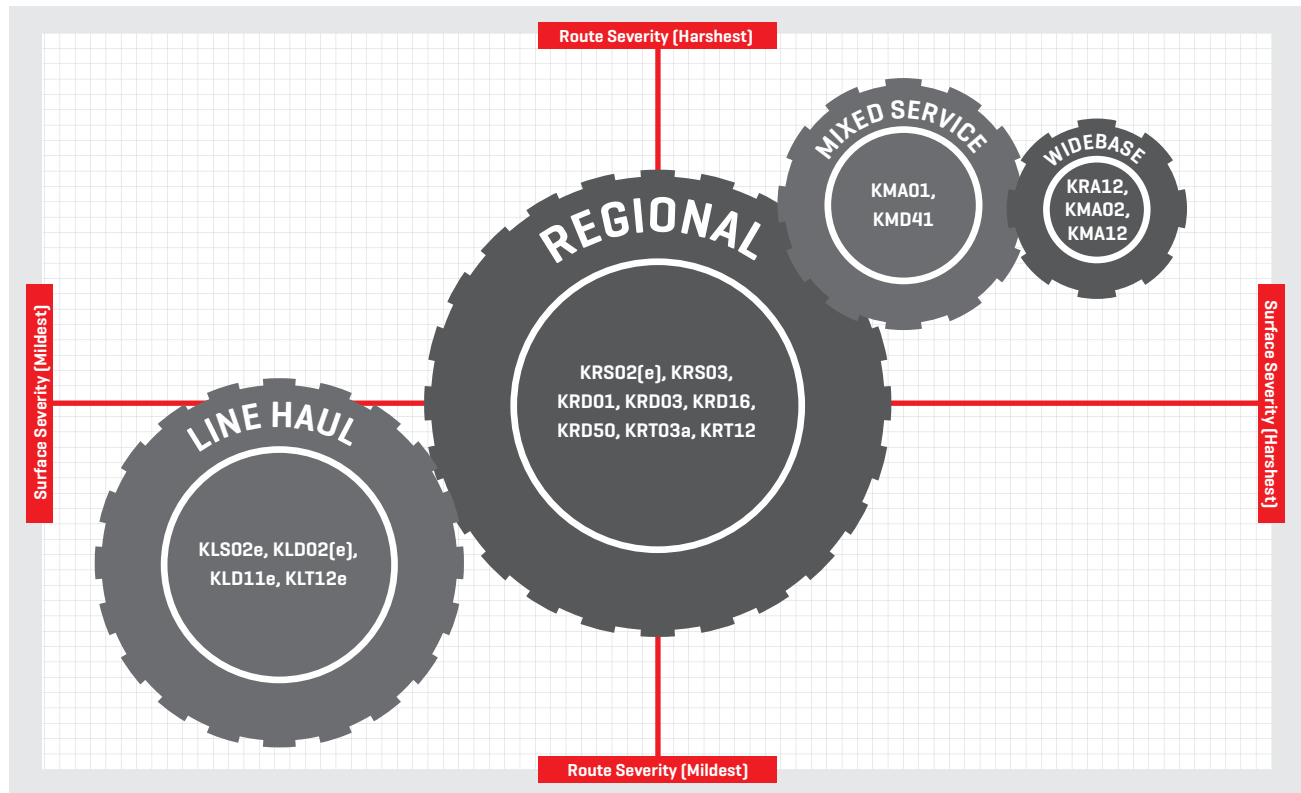

TECHNOLOGY

INTRODUCTION TO KUMHO TIRE

PERFORMANCE ANALYSIS

KUMHO has developed an exclusive performance analysis system for controlling & analyzing tire performance factors. These techniques are used to accurately measure various performance attributes of each tire.

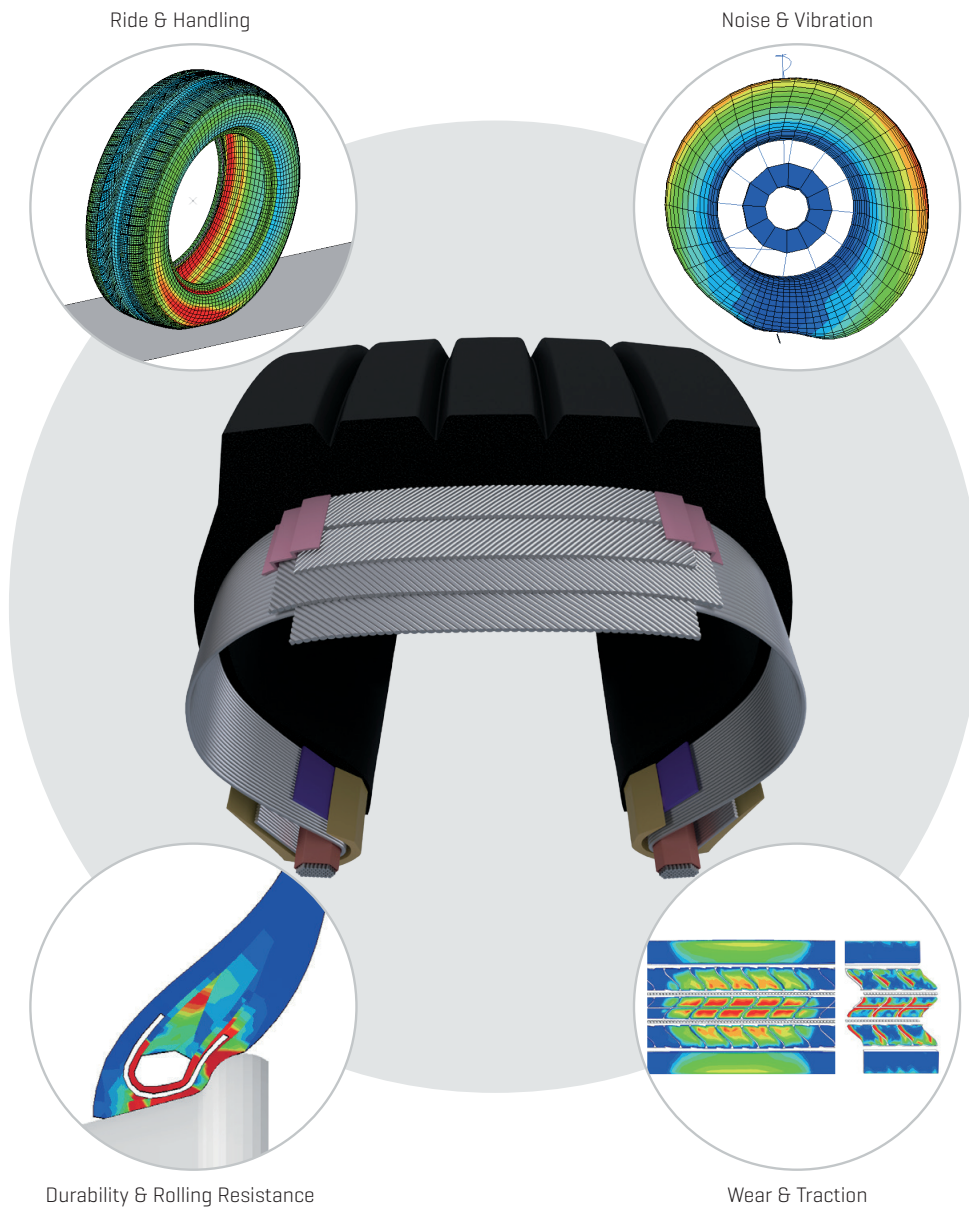

Ride & Handling

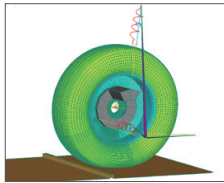

Cleat Impact
Analyzes ride performance

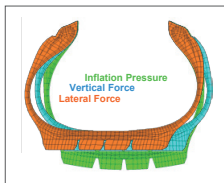
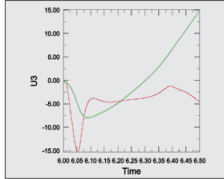

Tire Cornering State
Analyzes handling performance

Noise & Vibration

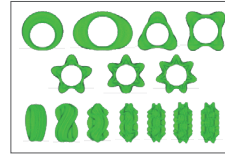

Modal Dynamic
Analyzes noise & vibration

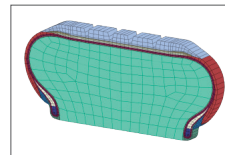

Air Cavity
Analyzes cavity noise performance

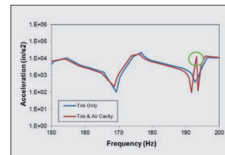

Performance Analysis

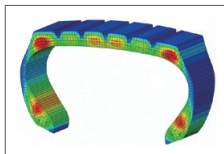

Tire Thermal
Analyzes temperature & rolling resistance

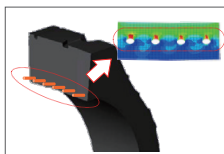

Stress-Strain
Analyzes carcass durability

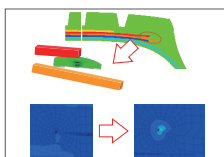

Crack Propagation
Analyzes tire fatigue life

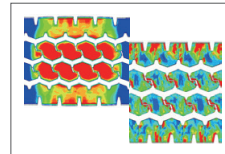

Dry Road
Analyzes footprint & even wear

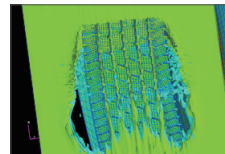

Wet Road
Analyzes hydroplaning performance

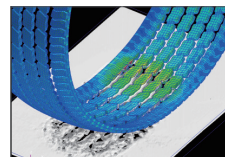

Snow Road
Analyzes snow traction & braking

Durability & Rolling Resistance

Wear & Traction

TECHNOLOGY

INTRODUCTION TO KUMHO TIRE

STRUCTURE OPTIMIZATION (ICOS)

- ICOS stands for Integrated Component Optimization System.
- This is the finite element design technology and optimization system used by KUMHO.
- ICOS enhances the performance of the tire through the optimal combination of shape, structure and materials. This is based on neural networks and genetic algorithms.

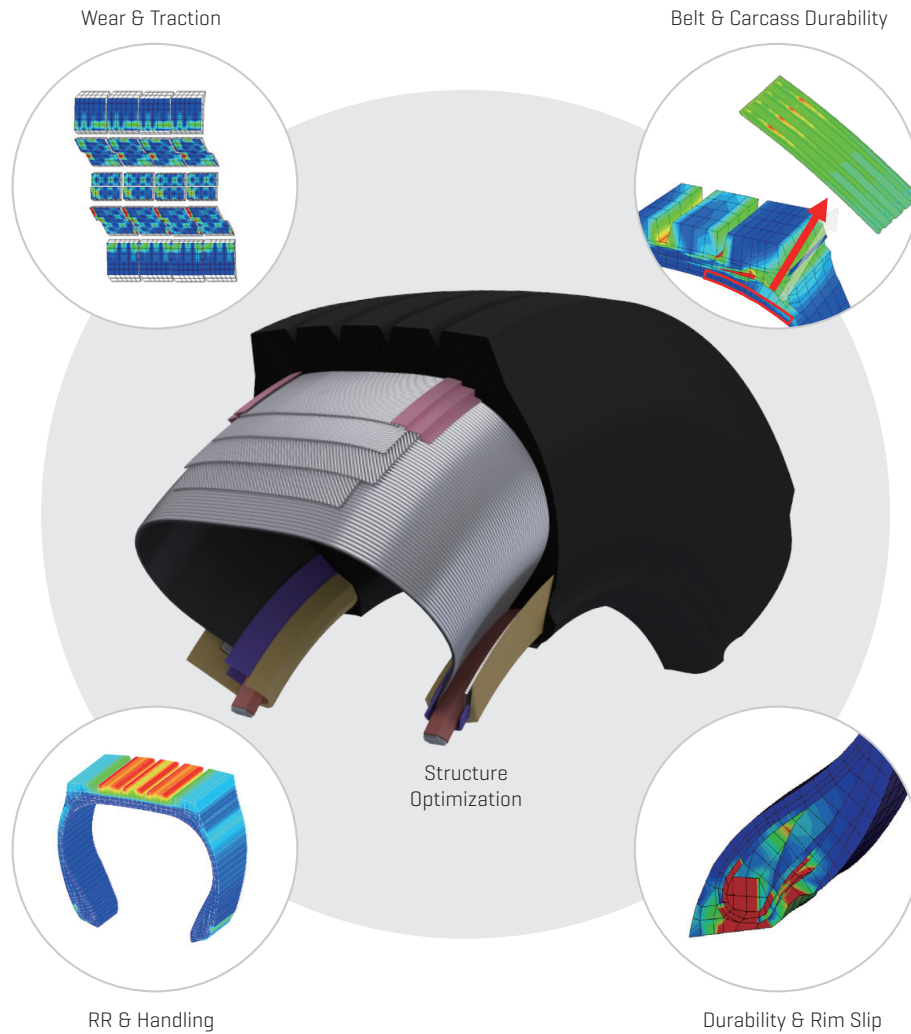

RUBBER COMPOUND TECHNOLOGY

We applied new materials, Surface Activated Carbon Black (SACB) and Low Heat Generation Carbon (LHGC), to develop new tread compound.

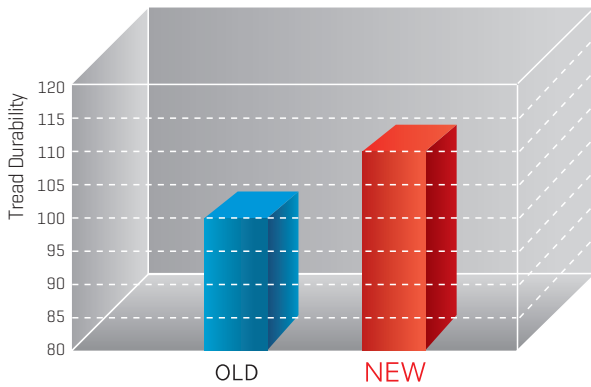
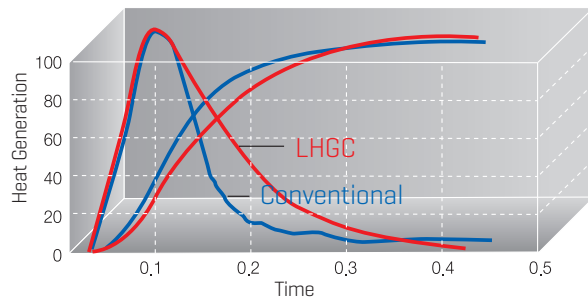
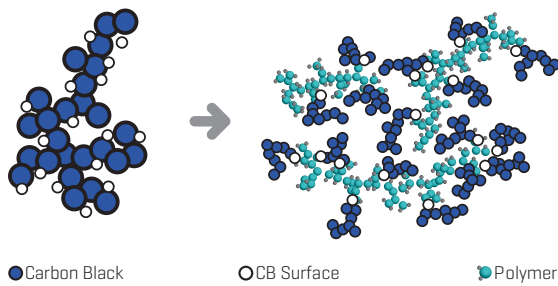

Improvement of Wear Performance
SACB has the best dispersion in the material matrix and best cohesion with Polymer Chain to improve wear and cut & chip performance.

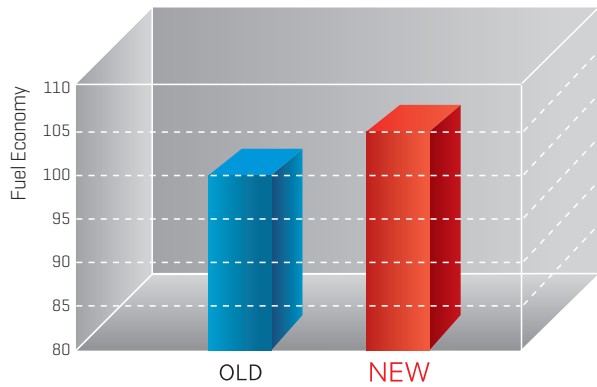

Improvement of Fuel Economy
LHGC increases the interaction in the Polymer-Filler to improve low heat generation performance and thereby minimizes energy loss. This improves fuel economy through decreasing Rolling Resistance.

SIDEWALL INFORMATION

TIRE BASIC KNOWLEDGE

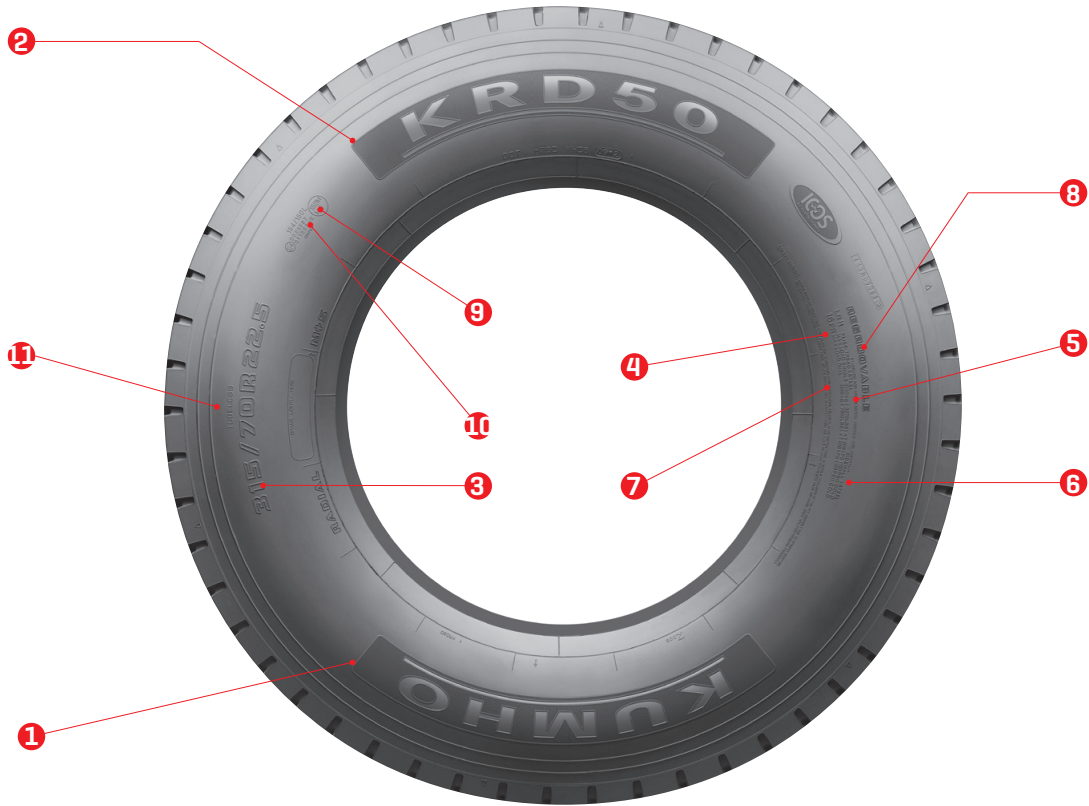

1 Manufacturers or Brand Name

2 Pattern Name

3 Size Information

Conventional	12	R	22.5
	Section Width(inch)	Radial	Rim Diameter(inch)
Low Profile	315 / 70	R	22.5
	Section Width(mm)	Series	Radial
Tube Type	11.00	R	20
	Section Width(inch)	Radial	Rim Diameter(inch)

4 Load Range

Load Range	PR	Load Range	PR
D	8	H	16
E	10	J	18
F	12	L	20
G	14	M	22

5 Tread Construction
Tread *steel

6 Sidewall Construction
Sidewall *steel

7 Max. Load
Max. load at Max. air inflation

Load Index	Max. Load(kg)	Load Index	Max. Load(kg)
90	600	135	2180
95	690	140	2500
100	800	145	2900
105	925	150	3350
110	1060	155	3875
115	1215	160	4500
120	1400	165	5150
125	1650	170	6000
130	1900	175	6900

8 Regroovable
It is permitted for the tire to be regrooved

9 Speed Symbol

Speed Symbol	Speed [km/h]	Speed Symbol	Speed [km/h]
E	70	M	130
F	80	N	140
G	90	P	150
J	100	Q	160
K	110	R	170
L	120	S	180

10 Load Index [Single/Dual]

11 Tube Type or Tubeless

Tube Type		Tubeless		
		90 Series	70, 80 Series	65 Series
7.00	R16	8 R17.5	205/75 R17.5	-
7.50	R16	8.5 R17.5	215/75 R17.5	-
8.25	R16	9.5 R17.5	245/70 R19.5	-
9.00	R20	10 R22.5	255/70 R22.5	-
10.00	R20	11 R22.5	275/70 R22.5	-
11.00	R20	12 R22.5	295/80 R22.5	385/65 R22.5
12.00	R20	13 R22.5	315/80 R22.5	425/65 R22.5

TIRE DIMENSIONS

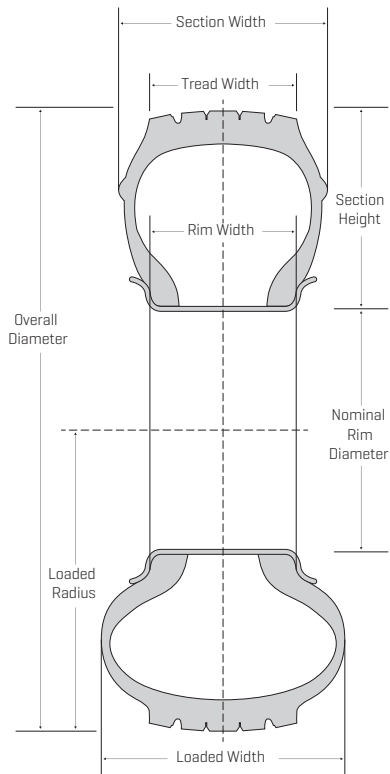

- Section Width: Distance between outside of sidewall and an opposite outside of sidewall.
- Tread Width: Distance across the tread face of an unloaded tire.
- Rim Width: Distance between the two opposite inside edges of the rim flanges.
- Section Height: Distance from the bead section to the tread surface of an unloaded tire.
- Nominal Rim Diameter: Diameter of the rim from bead section to bead in inches.
- Loaded Width: The maximum section width when the tire is loaded.
- Loaded Radius: The distance from the ground surface to the horizontal centerline of the tire & wheel assembly under maximum dual load and inflation pressure.
- Overall Diameter: The measurement of the distance of an unloaded tire between tread and an opposite side of tread.
- Aspect Ratio: Section Height / Section Width x 100%

KLS02e

The KLS02e utilizes design and engineering advancements to deliver improved steering stability, even tread wear and maximum mileage over the life of the tire.

BENEFITS & TECHNOLOGY

- Outstanding wet handling performance, provided by the five-rib, multi-sipe tread design
- Stabilized footprint pressure and better wear because of optimized belt widths
- Increased heat dissipation at the belt edge and minimized irregular wear are advantages of the top decoupling groove design
- Enhanced retreadability comes from groove bottom protectors designed to prevent stone drilling and stone retention



WHEEL POSITION

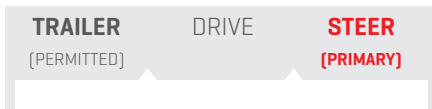

APPLICATION



Product Code	Tire Size	Ply Rating/Load Range	Measuring Rim Width	Max Load (lbs) @ Cold Infl. Pressure (psi) Single	Max Load (lbs) @ Cold Infl. Pressure (psi) Dual	Max Inflation Pressure (psi)	Diam. (in)	Section Width (in)	Approved Rim Width	Tread Depth (1/32")	RPM	Max Speed (mph)	Weight
2140923	11R22.5	14 Ply/G	8.25	6175	5840	105	41.3	10.9	7.50	18.0	503	75	121.9
2203633	11R22.5	16 Ply/H	8.25	6610	6005	120	41.3	10.9	7.50	18.0	503	75	121.9
2140953	295/75R22.5	14 Ply/G	11.00	6175	5675	110	40.3	11.0	8.25	18.0	516	75	116.7
2204353	295/75R22.5	16 Ply/H	11.00	7160	6610	120	40.3	11.0	8.25	18.0	516	75	116.7
2141013	11R24.5	14 Ply/G	8.25	6610	6005	105	43.3	10.9	7.50	18.0	480	75	130.1
2141043	285/75R24.5	14 Ply/G	8.25	6175	5675	110	41.4	10.8	7.50	18.0	502	75	119.5

KRS02(e)

A premium regional steer tire, the KRS02(e) features Tread Centering Groove Technology [TCG] for improved performance and tread wear uniformity. This outstanding all-position use tire was designed and engineered to meet the demanding requirements of regional and pickup and delivery applications.

BENEFITS & TECHNOLOGY

- Outstanding general purpose performance and all-position capable, featuring a non-decoupling groove and five-rib design
- Engineered and constructed for a long, original tread life with an improved 20/32 tread design
- Accurate toe-in setting provided by Tread Centering Groove Technology [TCG]
- Kumho SmartWay verified tires use special, low rolling resistance tread cap & base compounds to improve wear and fuel economy



WHEEL POSITION

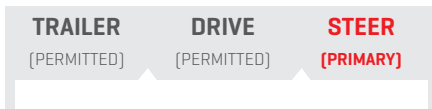

APPLICATION



Product Code	Tire Size	Ply Rating/Load Range	Measuring Rim Width	Max Load (lbs) @ Cold Infl. Pressure (psi) Single	Max Load (lbs) @ Cold Infl. Pressure (psi) Dual	Max Inflation Pressure (psi)	Diam. (in)	Section Width (in)	Approved Rim Width	Tread Depth (1/32")	RPM	Max Speed (mph)	Weight
1649613	10R22.5	14 Ply/G	7.50	5680	5360	115	40.2	9.9	7.50	18.0	517	75	106.5
2174693	11R22.5	16 Ply/H	8.25	6610	6005	120	41.3	10.9	7.50	20.0	503	75	120.7
2173423	12R22.5	16 Ply/H	9.00	7390	6780	120	42.8	11.5	8.25	20.0	485	75	135.0
1832413	255/70R22.5	16 Ply/H	7.50	5510	5070	120	36.5	9.6	7.50	18.0	569	75	95.8
2144923	295/75R22.5	14 Ply/G	9.00	6175	5675	110	40.4	10.9	7.50	20.0	514	75	116.0
2203653	295/75R22.5	16 Ply/H	9.00	7160	6610	120	40.4	10.9	7.50	19.5	516	75	116.0
1634813	11R24.5	16 Ply/H	8.25	7160	6610	120	43.4	10.9	7.50	20.0	479	75	128.8
1662513	285/75R24.5	14 Ply/G	8.25	6175	5675	110	41.6	10.6	7.50	20.0	500	75	121.1
2278673	7.5R16	14 Ply/G	6.00	3305	3195	105	31.7	8.1	5.50	14.0	659	75	57.1

KRS03

The KRS03 is the perfect choice for regional and pickup and delivery applications. This all-position rib tire was designed ideally for small and medium duty trucks using 19.5" and 22.5" tires.

BENEFITS & TECHNOLOGY

- Reduces progress of irregular wear due to lateral multi-sipes in the straight ribs
- Improved hydroplaning resistance and wet traction from S-shaped sipes in straight ribs
- Better traction and less stone holding is enhanced by variable geometry groove edges
- Excellent cost-per-mile, outstanding stability and confident handling, benefits of a wide, deep and efficient tread pattern



WHEEL POSITION

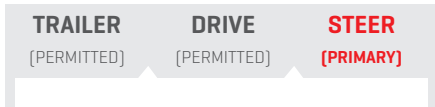

APPLICATION



Product Code	Tire Size	Ply Rating/Load Range	Measuring Rim Width	Max Load (lbs) @ Cold Infl. Pressure (psi) Single	Max Load (lbs) @ Cold Infl. Pressure (psi) Dual	Max Inflation Pressure (psi)	Diam. (in)	Section Width (in)	Approved Rim Width	Tread Depth (1/32")	RPM	Max Speed (mph)	Weight
2129753	225/70R19.5	14 Ply/G	6.75	3970	3750	110	31.9	8.7	7.50	16.0	652	75	66.0
1693213	245/70R19.5	14 Ply/G	7.50	4540	4375	110	33.4	9.5	7.50	17.0	622	75	79.6
1646013	275/70R22.5	16 Ply/H	8.25	6945	6395	125	38.0	10.8	7.50	20.0	547	75	109.6
1645913	315/80R22.5	20 Ply/L	9.00	9000	8270	130	42.4	12.1	9.00	20.0	490	75	145.2

KLD02(e)

The KLD02(e) is a long running, maximum mileage tire. Advancements in casing and tread technology place it at the top of the list for line-haul and regional drive applications.

BENEFITS & TECHNOLOGY

- Outstanding traction and wear resistance are provided by the closed shoulder ribs with intermediate support blocks design
- Excellent wet and dry traction due to its 30/32" molded rib/lug pattern and aggressive center rib buttons
- Increased high-speed stability achieved through advanced casing profile, which improves overall contact pressure
- Enhanced retreadability comes from groove bottom protectors designed to prevent stone drilling and stone retention



WHEEL POSITION



APPLICATION



Product Code	Tire Size	Ply Rating/Load Range	Measuring Rim Width	Max Load (lbs) @ Cold Infl. Pressure (psi) Single	Max Load (lbs) @ Cold Infl. Pressure (psi) Dual	Max Inflation Pressure (psi)	Diam. (in)	Section Width (in)	Approved Rim Width	Tread Depth (1/32")	RPM	Max Speed (mph)	Weight
2106913	11R22.5	14 Ply/G	8.25	6175	5840	105	42.1	10.9	7.50	30.0	494	75	129.0
2144903	295/75R22.5	14 Ply/G	9.00	6175	5675	110	41.1	11.3	8.25	30.0	506	75	125.7
2105603	11R24.5	14 Ply/G	8.25	6610	6005	105	44.1	10.9	7.50	30.0	471	75	137.5
2104753	285/75R24.5	14 Ply/G	8.25	6175	5675	110	42.2	10.7	7.50	30.0	492	75	125.8

KLD11e

KLD11e is intended to give longer mileage and better durability for any road it travels on. This product will perform and give great traction in any weather conditions it is faced with.

BENEFITS & TECHNOLOGY

- Provides more uniform wear and improves fuel economy.
- Enhanced block stiffness to improve mileage.
- Provides traction in all weather conditions.
- Minimizes tread block edge wear and prevents irregular wear.
- Designed for a longer tread life and lower rolling resistance.



WHEEL POSITION



APPLICATION



Product Code	Tire Size	Ply Rating/ Load Range	Measuring Rim Width	Max Load (lbs) @ Cold Infl. Pressure (psi) Single	Max Load (lbs) @ Cold Infl. Pressure (psi) Dual	Max Inflation Pressure (psi)	Diam. (in)	Section Width (in)	Approved Rim Width	Tread Depth (1/32")	RPM	Max Speed (mph)	Weight
2261363	11R22.5	14 Ply/G	8.25	6175	5840	105	41.7	11.0	7.50	26.0	498	75	124.5
2245933	295/75R22.5	14 Ply/G	9.00	6175	5675	110	40.8	11.5	8.25	26.0	490	75	116.0
2251643	11R24.5	14 Ply/G	8.25	6610	6005	105	43.8	10.9	7.50	26.0	477	75	132.8
2261353	285/75R24.5	14 Ply/G	8.25	6175	5675	110	41.9	10.9	7.50	26.0	495	75	122.0

KRD01

The KRD01 was specifically designed and engineered for maximum tread life and long performance in high scrub, fast wear applications. A great choice for regional and pickup and delivery use, the tire's wider and flatter tread arc produces improved and more uniform tread wear characteristics.

BENEFITS & TECHNOLOGY

- Improved durability and overall wear because of a new mold shape featuring a flatter tread radius
- Low running temps and long wear are achieved through improved compounding and an extra deep 28/32" tread pattern
- Even wear is optimized by a solid shoulder and center lug design
- Minimized stone holding and drilling, the benefits of engineered stone protectors



WHEEL POSITION



APPLICATION

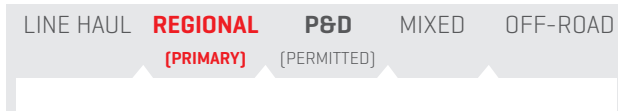

Product Code	Tire Size	Ply Rating/Load Range	Measuring Rim Width	Max Load (lbs) @ Cold Infl. Pressure (psi) Single	Max Load (lbs) @ Cold Infl. Pressure (psi) Dual	Max Inflation Pressure (psi)	Diam. (in)	Section Width (in)	Approved Rim Width	Tread Depth (1/32")	RPM	Max Speed (mph)	Weight
1628113	11R22.5	16 Ply/H	8.25	6610	6005	120	41.9	10.9	7.50	28.0	496	75	129.9
1658013	295/75R22.5	14 Ply/G	9.00	6175	5675	110	40.9	11.0	7.50	28.0	508	75	119.4
1648113	11R24.5	16 Ply/H	8.25	7160	6610	120	43.9	10.9	7.50	28.0	473	75	138.4
1657913	285/75R24.5	14 Ply/G	8.25	6175	5675	110	42.1	10.6	7.50	28.0	494	75	124.4

KRD03

The KRD03 is a full 26/32" deep tread, open shoulder tire that was designed to provide excellent traction and high original tread mileage in faster wearing applications. Engineered with close-packed, high-density center elements for maximized grip, tread wear and durability.

BENEFITS & TECHNOLOGY

- Sturdy, wear-and-tear resistant tread block engineering
- Long-term casing life and performance, benefits of high strength, flex and fatigue resistant ply wire construction
- Exceptional casing stability and tread wear due to full, four belt design
- High net-to-gross block design with wide TAW



WHEEL POSITION



APPLICATION

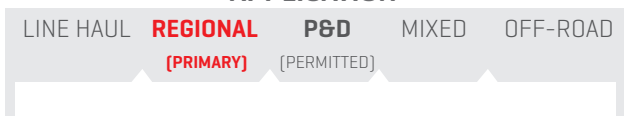

Product Code	Tire Size	Ply Rating/Load Range	Measuring Rim Width	Max Load (lbs) @ Cold Infl. Pressure (psi) Single	Max Load (lbs) @ Cold Infl. Pressure (psi) Dual	Max Inflation Pressure (psi)	Diam. (in)	Section Width (in)	Approved Rim Width	Tread Depth (1/32")	RPM	Max Speed (mph)	Weight
1683213	11R22.5	16 Ply/H	8.25	6610	6005	120	41.8	10.9	7.50	27.0	497	75	128.5
1698813	11R24.5	16 Ply/H	8.25	7390	6780	120	43.8	10.9	7.50	27.0	474	75	137.0

KRD16

The KRD16 features a deep tread pattern for extended tread wear and excellent CPK. A heat-resistant compound reduces uneven wear and extends casing life. This tire is suited to heavy load applications.

BENEFITS & TECHNOLOGY

- Deep and wide tread design to provide outstanding performance and extended tread life
- Maximum wear and grip with open shoulder
- Multi-pitch tread pattern for low noise

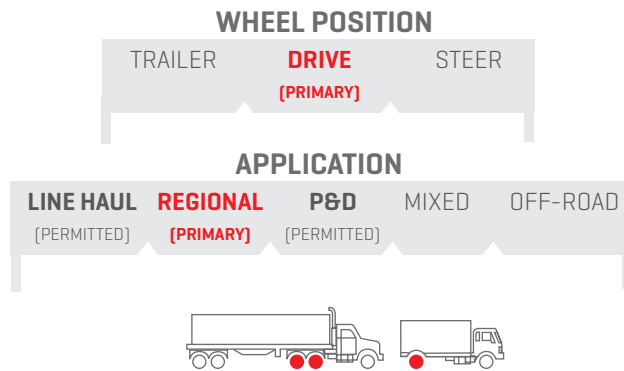

Product Code	Tire Size	Ply Rating/Load Range	Measuring Rim Width	Max Load (lbs) @ Cold Infl. Pressure (psi) Single	Max Load (lbs) @ Cold Infl. Pressure (psi) Dual	Max Inflation Pressure (psi)	Diam. (in)	Section Width (in)	Approved Rim Width	Tread Depth (1/32")	RPM	Max Speed (mph)	Weight
2262193	225/70R19.5	14 Ply/G	6.75	3970	3750	110	32.3	8.8	7.50	19.5	643	75	66.7

KRD50

With an all new tread design, the KRD50 has improved cut & chip resistance along with excellent forward traction on both highway and off-road surfaces. The innovative compound is formulated to maximize tread wear performance.

BENEFITS & TECHNOLOGY

- Cut and chip resistant and balanced wear
- Wide and deep tread with balanced contact patch for high mileage
- Application of angled square grooves to prevent abnormal wear

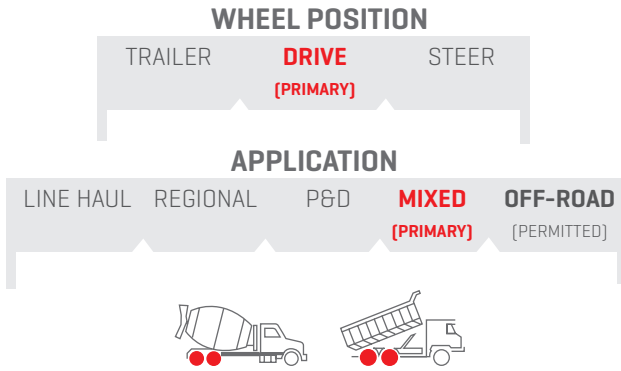

Product Code	Tire Size	Ply Rating/ Load Range	Measuring Rim Width	Max Load (lbs) @ Cold Infl. Pressure (psi) Single	Max Load (lbs) @ Cold Infl. Pressure (psi) Dual	Max Inflation Pressure (psi)	Diam. (in)	Section Width (in)	Approved Rim Width	Tread Depth (1/32")	RPM	Max Speed (mph)	Weight
2141483	245/70R19.5	16 Ply/H	7.50	5070	4850	120	33.6	10.2	7.50	19.0	595	75	88.5

KMD41

The KMD41 was designed using Kumho Tire's ICOS[Integrated Component Optimization System]. This proprietary technology optimizes tire casing shape, which redirects stress in critical areas. The result is maximum durability in a true mixed-service tire that delivers long tread life at highway speeds.

BENEFITS & TECHNOLOGY

- Engineered for mixed service, non-speed restricted highway use - max 68 mph
- Maximum traction and tread wear performance from the aggressive 31/32" multi-lug design
- Long, even wear in the drive axle position due to its optimized tread radius



WHEEL POSITION



APPLICATION



Product Code	Tire Size	Ply Rating/Load Range	Measuring Rim Width	Max Load (lbs) @ Cold Infl. Pressure (psi) Single	Max Load (lbs) @ Cold Infl. Pressure (psi) Dual	Max Inflation Pressure (psi)	Diam. (in)	Section Width (in)	Approved Rim Width	Tread Depth (1/32")	RPM	Max Speed (mph)	Weight
2147103	11R22.5	16 Ply/H	8.25	6610	6005	120	42.0	10.9	7.50	30.0	495	68	131.9
2147123	11R24.5	16 Ply/H	8.25	7160	6610	120	44.1	10.9	7.50	30.0	471	68	139.5

KLT12e

Designed primarily as an over-the-road trailer tire, the KLT12e delivers low rolling resistance, minimized shoulder wear and longer mileage.

BENEFITS & TECHNOLOGY

- Cut and chip resistant and balanced wear
- Wide and deep tread with balanced contact patch for high mileage
- Application of angled square grooves to prevent abnormal wear



WHEEL POSITION

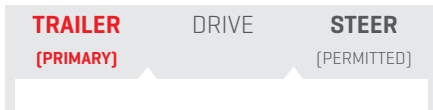

APPLICATION



Product Code	Tire Size	Ply Rating/Load Range	Measuring Rim Width	Max Load (lbs) @ Cold Infl. Pressure (psi) Single	Max Load (lbs) @ Cold Infl. Pressure (psi) Dual	Max Inflation Pressure (psi)	Diam. (in)	Section Width (in)	Approved Rim Width	Tread Depth (1/32")	RPM	Max Speed (mph)	Weight
2246223	11R22.5	14 Ply/G	8.25	6175	5840	105	40.8	10.9	7.50	13.5	509	75	105.8
2176123	295/75R22.5	14 Ply/G	8.25	6175	5675	110	39.8	10.9	7.50	13.0	522	75	107.2
2253313	11R24.5	14 Ply/G	8.25	6610	6005	105	44.1	10.9	7.50	13.5	483	75	113.2
2246213	285/75R24.5	14 Ply/G	8.25	6175	5675	110	40.9	10.6	7.50	13.5	508	75	104.9

KRT03a

The KRT03a is set to provide excellent traction and removal mileage. It is also geared to improve your fuel economy and has even wear and casing durability for retreading.

BENEFITS & TECHNOLOGY

- Deep and wide tread design enhances mileage and provides even wear
- Application of stone ejectors in all grooves for effective clearing of debris
- Optimized tread design and construction to provide even load distribution
- Cut and chip resistant compound to enhance durability

WHEEL POSITION

TRAILER DRIVE STEER
[PRIMARY]

APPLICATION

LINE HAUL **REGIONAL** P&D MIXED OFF-ROAD
 [PERMITTED] **[PRIMARY]**



Product Code	Tire Size	Ply Rating/Load Range	Measuring Rim Width	Max Load (lbs) @ Cold Infl. Pressure (psi) Single	Max Load (lbs) @ Cold Infl. Pressure (psi) Dual	Max Inflation Pressure (psi)	Diam. (in)	Section Width (in)	Approved Rim Width	Tread Depth (1/32")	RPM	Max Speed (mph)	Weight
2146833	215/75R17.5	16 Ply/H	6.00	4805	4540	125	30.5	8.5	7.50	16.0	681	62	64.6
2152753	235/75R17.5	18 Ply/J	6.75	6005	5675	125	31.5	9.4	7.50	16.0	660	62	74.3
2270223	255/70R22.5	16 Ply/H	7.50	5510	5070	120	36.4	9.7	7.50	16.4	571	62	93.0

KRT12

This product is an improved high-capacity trailer tire. The KRT12 is intended for high load service in both regional and P&D applications.

BENEFITS & TECHNOLOGY

- Optimized flatter tread radius to enhance mileage and provide even contact pressure to avoid irregular wear
- Wide 3x5 rib style tread pattern with increased shoulder rigidity
- Designed to withstand high-scrub conditions

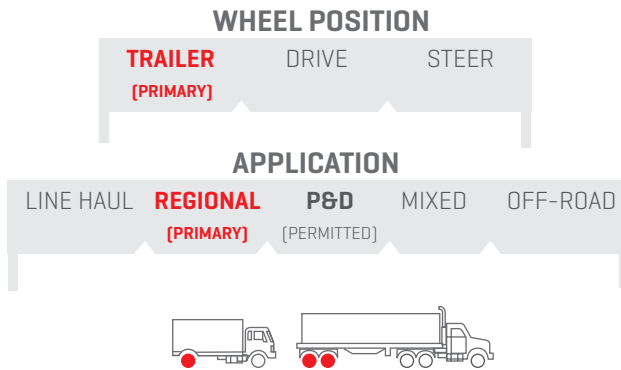

Product Code	Tire Size	Ply Rating/Load Range	Measuring Rim Width	Max Load (lbs) @ Cold Infl. Pressure (psi) Single	Max Load (lbs) @ Cold Infl. Pressure (psi) Dual	Max Inflation Pressure (psi)	Diam. (in)	Section Width (in)	Approved Rim Width	Tread Depth (1/32")	RPM	Max Speed (mph)	Weight
2210203	11R22.5	14 Ply/G	8.25	6175	5840	105	40.9	10.9	7.50	17.0	508	75	110.3
2219263	295/75R22.5	14 Ply/G	9.00	6175	5675	110	40.0	10.9	7.50	16.0	520	75	107.3
2210233	11R24.5	14 Ply/G	8.25	6610	6005	105	43.0	10.9	7.50	17.0	483	75	118.0

KRA12

The KRA12 is available in wide-base sizes and features an aggressive 6-rib tread pattern with large, full depth tread sipes. This tire will deliver increased mileage, endurance, and better traction versus other regional truck tires.

BENEFITS & TECHNOLOGY

- Robust under tread to resist cutting and stone damage
- Improved durability and resistance to uneven wear
- Six-rib design to provide excellent tread wear and traction



WHEEL POSITION

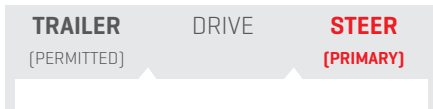

APPLICATION

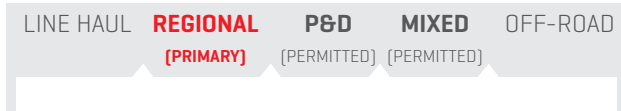

Product Code	Tire Size	Ply Rating/Load Range	Measuring Rim Width	Max Load (lbs) @ Cold Infl. Pressure (psi) Single	Max Load (lbs) @ Cold Infl. Pressure (psi) Dual	Max Inflation Pressure (psi)	Diam. (in)	Section Width (in)	Approved Rim Width	Tread Depth (1/32")	RPM	Max Speed (mph)	Weight
2218513	385/65R22.5	18 Ply/J	11.75	9370	-	120	42.1	15.0	11.75	20.0	494	75	165.4
2218503	425/65R22.5	20 Ply/L	12.25	11355	-	120	44.3	16.6	11.75	20.0	469	68	188.1

KMA01

The KMA01 is a purpose-built on/off road tire that provides excellent cut and chip resistant as well as exceptional overall wear characteristics. With a sturdy four-rib design, the primary wheel positions for the KMA01 are steer and trailer.

BENEFITS & TECHNOLOGY

- Driving stability and increased removal mileage are provided by superior bead strength and tire uniformity
- Enhanced casing integrity and uniformity are the results of an advanced belt package, providing higher retread quality
- Excellent removal mileage, the benefit of a durable, cut and chip resistant compound molded into a closed shoulder and block pattern
- Enhanced retreadability comes from groove bottom protectors designed to prevent stone drilling and stone retention



WHEEL POSITION

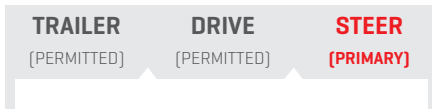

APPLICATION

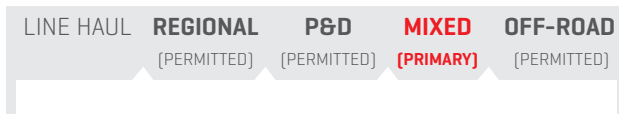

Product Code	Tire Size	Ply Rating/Load Range	Measuring Rim Width	Max Load (lbs) @ Cold Infl. Pressure (psi) Single	Max Load (lbs) @ Cold Infl. Pressure (psi) Dual	Max Inflation Pressure (psi)	Diam. (in)	Section Width (in)	Approved Rim Width	Tread Depth (1/32")	RPM	Max Speed (mph)	Weight
1804813	315/80R22.5	20 Ply/L	9.00	10200	9090	130	42.7	12.1	9.00	23.0	487	68	155.9
1825913	11R22.5	16 Ply/H	8.25	6610	6005	120	41.6	10.9	7.50	23.0	500	68	128.1
1826013	11R24.5	16 Ply/H	8.25	7160	6610	120	44.1	10.9	7.50	23.0	471	68	136.3

KMA02

The KMA02 is designed with a wide footprint and provides improved stability. Stone ejectors in the center groove assure casing durability, and tie-bars between the tread blocks minimize uneven wear.

BENEFITS & TECHNOLOGY

- Outstanding traction and high removal mileage, results of block stiffness and optimum contact patch engineering
- Increased durability and removal mileage optimized by an open shoulder design which migrates into a closed shoulder block joined by tie-bars
- Enhanced retreadability comes from groove bottom protectors designed to prevent stone drilling and stone retention



WHEEL POSITION

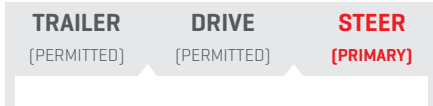

APPLICATION



Product Code	Tire Size	Ply Rating/Load Range	Measuring Rim Width	Max Load (lbs) @ Cold Infl. Pressure (psi) Single	Max Load (lbs) @ Cold Infl. Pressure (psi) Dual	Max Inflation Pressure (psi)	Diam. (in)	Section Width (in)	Approved Rim Width	Tread Depth (1/32")	RPM	Max Speed (mph)	Weight
1687113	385/65R22.5	18 Ply/J	11.75	9370	-	120	42.1	15.0	11.75	21.0	494	75	170.3
2109393	425/65R22.5	20 Ply/L	12.25	11400	-	120	44.5	16.0	11.75	21.0	467	68	192.0

KMA12

The KMA12 is resistant to stone retention and drilling with an application of dual tie-bars and balanced footprint to provide durability and longer tread life. With an improved block design comes enhanced braking and traction performance.

BENEFITS & TECHNOLOGY

- Tread compound formulated to resist cutting and chipping
- Wide and reinforced chafer minimizes deformation of the bead area
- Application of 'zig-zag' groove design for excellent 'stop and go' performance

WHEEL POSITION

TRAILER [PERMITTED]	DRIVE [PERMITTED]	STEER [PRIMARY]
-------------------------------	-----------------------------	---------------------------

APPLICATION

LINE HAUL	REGIONAL [PERMITTED]	P&D [PERMITTED]	MIXED [PRIMARY]	OFF-ROAD [PERMITTED]
-----------	--------------------------------	-------------------------------	---------------------------	--------------------------------



Product Code	Tire Size	Ply Rating/Load Range	Measuring Rim Width	Max Load (lbs) @ Cold Infl. Pressure (psi) Single	Max Load (lbs) @ Cold Infl. Pressure (psi) Dual	Max Inflation Pressure (psi)	Diam. (in)	Section Width (in)	Approved Rim Width	Tread Depth (1/32")	RPM	Max Speed (mph)	Weight
2271573	425/65R22.5	20 Ply/L	12.50	11400	-	120	44.4	16.2	13.00	23.0	454	68	190.7
2271583	445/65R22.5	20 Ply/L	13.00	12300	-	120	45.8	17.4	14.00	23.0	440	68	211.7



WARRANTY POLICIES

CONSUMER LIMITED WARRANTY FOR KUMHO & MARSHAL BRAND MEDIUM COMMERCIAL TRUCK TIRES

I. WHAT IS WARRANTED AND WHO IS ELIGIBLE UNDER THIS WARRANTY

Kumho Tire U.S.A. Inc., 133 Peachtree St NE, Suite 2800, Atlanta, GA 30303, warrants to the original consumer purchaser that all KUMHO replacement radial tires either directly or through an authorized KUMHO dealer, and which are mounted on vehicles within the U.S.A., and becomes unserviceable for any reason within the manufacturers control, such tire will be replaced with an equivalent KUMHO tire OR one that Kumho approves. This warranty only applies if the following requirements are met:

- The tire is size, load rating, and speed rating that the vehicle manufacturer states.
- The tire has not become unserviceable due to any condition listed under WHAT IS NOT COVERED BY THE WARRANTY.

WHAT IS COVERED BY THE WARRANTY AND HOW LONG:

The life of the original usable tread has worn down to 2/32" remaining [worn down to the built-in indicators in the tread grooves] before 5 years [6 years for KLS02e, KLD11e, KLD02 (e), KLD01e and KLT12e patterns] from the date of manufacture or purchase date for commercial truck tires [whichever comes first], any new tire manufactured by Kumho Tire Co., Inc. covered by this warranty becomes unserviceable due to a material or workmanship condition, KUMHO will do either of the following:

- A. During the first 2/32" of the original usable tread, Kumho will replace such tire with a comparable new KUMHO or Marshal tire free of charge. Applicable taxes on the new tire, and costs of mounting and balancing and any other service charges are required to be paid by the owner.
- B. After the first 2/32" of the original usable tread, a credit percentage will be given toward the purchase price of a comparable new Kumho or Marshal tire effective at the time of adjustment. Applicable taxes on the new tire and costs of mounting and balancing service are required to be paid by the owner.

To obtain the credit percentage, please refer to the Adjustment Credit Percentage Table on page 43 or utilize the following example:

R.T.D.: Remaining Tread Depth

O.T.D.: Original Tread Depth

If R.T.D. = 10 and O.T.D. = 20, the calculation is
[10-2: remaining useable tread depth] ÷
[20-2: original useable tread depth] = 44%

- C. Adjustment on ride complaint or out-of-round is allowed only during the first 2/32" of the original tread depth or 1 year from purchase date [proof of purchase required] whichever comes first.

WHAT IS NOT COVERED BY THE WARRANTY:

- A. Mileage or treadwear on Medium Commercial Kumho tires.
- B. This limited warranty is applicable only in the United States, and any tires used or equipped on a vehicle registered or operated outside

the U.S. are not covered by this warranty.

- C. Tires branded or marked "Non-Adjustable [NA] or Blemished [Blem] or DOT/Serial numbers previously cut or buffed will not be adjusted.
- D. Any tire worn beyond the wear bars [less than 2/32" remaining tread].
- E. The cost of applicable taxes and mounting and balancing and any other service charges.
- F. Tire damage or irregular wear due to any of the following:
 - Road hazard, including puncture, cut, impact break, bulge, snap, stone drill, collision.
 - Continued use while run flat or under acute under-inflation.
 - Improper use or operation, without limitation, improper inflation pressure, improper retreading process, overloading, use of an improper rim, tire/wheel assembly imbalance or other vehicle condition, worn suspension components, improper mounting or de-mounting, misuse, misapplication, fire or other externally generated heat, water or other material trapped inside the tire during mounting, tire alteration, racing or competition purposes, improper inserting of sealant, balance or filler materials.
 - Improper repair, or with repairs not conforming to the United States Tire Manufacturer's Association [USTMA] standards, or with section repairs, or with self-vulcanizing plug only.
 - Uneven or rapid wear which is caused by mechanical irregularity in the vehicle such as misalignment [a measured tread difference of 2/32nds of an inch or more across the tread on the same tire].
- G. Ozone or weather cracking on tires over four [4] years from the date of the manufacture.
- H. Ride disturbance [out-of-round, vibration, pulling, etc.] claims submitted after the first 2/32" of tread wear or 1 year from purchase [proof of purchase required] whichever comes first.
- I. Loss of time, or use, inconvenience, or any incidental or consequential damage.
- J. Tires that have been modified by the addition or removal of material or any tire intentionally altered to change its appearance.
- K. Tires unserviceability caused by the tire operation in excess of tire/wheel manufacturers specifications and recommendations.
- L. Tires that are misapplied due to insufficient speed rating, or undersized, or oversized tires.
- M. Tires that have become unserviceable because chemical corrosion, vandalism, chains and flat spotting.
- N. Tires involved in any racing-related activities.
- O. This limited warranty applies only to the original purchaser and is non-transferable.

WARRANTY POLICIES

OWNER'S OBLIGATION:

In order to be eligible for KUMHO's limited warranty service the owner must:

- A. Present the tire and original purchase receipt to any authorized KUMHO Medium Commercial Tire dealer in the continental USA.
- B. Complete and sign a KUMHO warranty claim form, which is available at any authorized dealer.
- C. Pay the amounts due on a new tire, less the amount of credit (if issued), including taxes, mounting and balancing charges and/or the cost of other services ordered.
- D. If requested by Kumho Tire, you must make available for inspection the vehicle on which the Kumho tire was mounted.

To locate an authorized KUMHO/Marshall dealer, please use our web address: <http://www.kumhotire.com/us/index.do>.

OTHER RIGHTS:

This limited warranty gives the owner of KUMHO tires specific legal rights and you may also have other rights, which vary from state to state.

NEW TIRE D.O.T. (DEPARTMENT OF TRANSPORTATION) REGISTRATION:

It is important that you properly register your tire(s) D.O.T. codes promptly after purchase. Tire D.O.T. registration is an important safety procedure as it allows the manufacturer to notify you in the event of a recall. To complete registration, you will need to provide:

1. Your contact information.
2. The tire D.O.T. codes located on the side of the tire(s).
3. Your dealer's contact information (where you purchased the tires from). Please use the registration form available from Kumho at: <http://www.kumhotire.com/us/global/tire/tireBasics/write.do>.

II. CASING CREDIT

1. Casing of KUMHO radial commercial truck tires are warranted to remain serviceable through the second retreaded life for 66 months from the date of manufacture.
2. KLS02e, KLD11e, KLD02 (e), KLD01e and KLT12e casing warranty is valid through the second retreaded life for 72 months from the date of manufacture.
3. If an examination by KUMHO shows that a casing of a KUMHO radial truck tire delivers unsatisfactory service due to factors within the manufacturer's control, KUMHO will give a credit toward the purchase price of a comparable new KUMHO tire in the amount indicated in the Casing Credit table.

3. If an examination by KUMHO shows that a casing of a KUMHO radial truck tire delivers unsatisfactory service due to factors within the manufacturer's control, KUMHO will give a credit toward the purchase price of a comparable new KUMHO tire in the amount indicated in the Casing Credit table.

Tire Size:	Casing Value	Tire Size:	Casing Value
7.50R16	\$30.00	12.00R24	\$50.00
215/75R17.5	\$30.00	12R22.5	\$80.00
235/75R17.5	\$30.00	315/80R22.5	\$80.00
225/70R19.5	\$30.00	385/65R22.5	\$80.00
245/70R19.5	\$30.00	425/65R22.5	\$80.00
265/70R19.5	\$30.00	445/65R22.5	\$80.00
255/70R22.5	\$50.00	11R22.5	\$90.00
275/70R22.5	\$50.00	295/75R22.5	\$90.00
9.00R20	\$50.00	11R24.5	\$90.00
10R22.5	\$50.00	285/75R24.5	\$90.00
10.00R20	\$50.00		

4. Radial truck tires used in mining service are not eligible under this program.

III. REPLACEMENT WARRANTY

If you receive a replacement tire under this warranty, it will be covered by the manufacturer's warranty.

THIS IS THE ONLY EXPRESS WARRANTY GIVEN BY KUMHO APPLICABLE TO KUMHO/MARSHAL Replacement TIRES. KUMHO DOES NOT MAKE ANY OTHER EXPRESS WARRANTY OR IMPLIED WARRANTY OF MERCHANT ABILITY OR FITNESS FOR A PARTICULAR PURPOSE.

KUMHO DOES NOT AUTHORIZE ANY OTHER PERSONS, INCLUDING AUTHORIZED DEALERS TO CHANGE THIS WARRANTY OR CREATE ANY OTHER OBLIGATION IN CONNECTION WITH KUMHO/MARSHAL TIRES. KUMHO WILL NOT DO ANYTHING OTHER THAN WHAT IS STATED IN THIS WARRANTY IF A DEFECT IS FOUND TO EXIST IN A KUMHO/MARSHAL REPLACEMENT RADIAL TIRE. ALL OTHER REMEDIES ARE EXCLUDED, INCLUDING ANY OBLIGATION OR LIABILITY ON THE PART OF KUMHO FOR CONSEQUENTIAL OR INCIDENTAL DAMAGES [SUCH AS LOSS OF USE OF VEHICLE, LOSS OF TIME OR INCONVENIENCE] ARISING OUT OF A DEFECT.

THE REMEDIES SET FORTH IN THIS LIMITED WARRANTY ARE THE SOLE AND EXCLUSIVE REMEDIES FOR BREACH OF WARRANTY. SOME STATES DO NOT ALLOW THE EXCLUSION OR LIMITATION OF INCIDENTAL OR CONSEQUENTIAL DAMAGES, SO THE ABOVE LIMITATIONS OR EXCLUSIONS MAY NOT APPLY TO YOU. THIS WARRANTY GIVES YOU SPECIFIC LEGAL RIGHTS, AND YOU MAY ALSO HAVE OTHER RIGHTS THAT MAY VARY FROM STATE TO STATE.

WARRANTY POLICIES

SAFETY WARNINGS

Property damage, serious personal injury or death may result if any of the following safety precautions/recommendations are not followed:

Driving on any underinflated tire is dangerous and may result in sudden tire destruction caused by excessive heat build-up. For replacement tires, your tire retailer should provide you with the proper inflation pressure. Otherwise, follow the air pressure recommendation found within your vehicle's owner manual or tire placard in your vehicle. Always make sure the air pressure is correct to support vehicle's GVWR.

- Check the cold inflation pressure in all of your tires, including the spare tire, at least once every week and always prior to long distance trips. Failure to maintain the proper air inflation pressure may result in improper vehicle handling, and may cause rapid and irregular tire wear, reduction in tire durability, loss of vehicle control, or sudden tire failure that may lead to property damage, serious personal injury or death.
- Use an accurate tire gauge to check tire air pressures. Always maintain the proper recommended air inflation pressure in all tires. If there is an indication that one of your tires has lost four or more pounds of air pressure, immediately look for signs of penetration through the tire, valve leaks or wheel damage that may account for the air loss. You should also have your tires inspected by a tire retailer immediately.
- Air pressure should be checked when tires are cold (before they have been driven), ideally in the early morning. Driving, regardless of distance, causes tires to heat up and simultaneously increase air pressure.
- Never exceed the maximum inflation pressure for the tire.
- Never bleed air from hot tires as this may result in under-inflation. Inspect your tires daily. If you notice any damage to your tires or wheels, replace them with a spare and immediately visit any tire retailer for advice. Driving over potholes, curbs, wood debris, metal, etc., can damage a tire and should be safely avoided. Contact with such hazards requires an immediate and thorough tire inspection by your tire retailer.
- Always examine your tires for penetrations, bulges, cracks, cuts, and abnormal wear – particularly at the tire edges – which may be caused by, for example, vehicle misalignment or tire under-inflation. Failure to properly control a vehicle when one or more tires are underinflated may result in an accident. Use of a damaged tire may result in rapid air loss, including sudden tire failure.
- An explosion of the tire/rim assembly may occur due to improper mounting. Only specially trained persons should mount tires. Failure to store tires in accordance with the following recommendations may result in damage to your tires, reduction in tire durability, or sudden tire failure. For more information, please refer to the OSHA link provided:
<http://www.osha.gov/Publications/wheel/wheel-chart-booklet.pdf>

- Tires should always be stored in a cool, dry, clean, indoor environment. Tires contain waxes and emollients to protect their outer surfaces from ozone and weather cracking. As the tire rolls and flexes, the waxes and emollients continually migrate to the tire's surface, replenishing this protection throughout the normal and proper use of the tire. However, when tires sit outdoors and are unused for an extended period of time, the tire surface becomes dry, the tire may be susceptible to ozone and weather cracking, and the casing becomes susceptible to flat spotting.
- Surfaces on which tires are stored must be free from grease, gasoline, and other substances that could deteriorate the rubber.
- You should have a qualified technician check all tires where the Kumho Tire U.S.A., Inc. warranty policy period has lapsed, even if damage is not obvious.

Do not overload your tires. Driving on any overloaded tire is extremely dangerous and may result in an accident causing property damage, serious personal injury or death.

- The maximum load rating marked on the sidewall of any tire is based on the maximum speed of operation. Tires that are loaded beyond their maximum allowable loads for a particular application will generate increased and excessive heat that may cause sudden tire failure leading to property damage, serious personal injury or death.

©2020 Kumho Tire USA, Inc.

All specifications shown in this catalog cancel, supersede and replace those shown on prior dated catalogs and are subject to change without notice. Weights shown in this catalog are approximate and subject to change. Actual weights will be used at the time of shipment.

Nothing in this warranty is intended to be a representation by Kumho Tire that tire failure cannot occur.

For more safety information, please visit:

- www.ustires.org
- www.nhtsa.gov
- www.safercar.gov
- www.nsc.org

WARRANTY POLICIES

ADJUSTMENT CREDIT PERCENTAGE Percentage KUMHO TIRE pays based on Remaining Tread Depth

R.T.D. (Remaining Tread Depth)	O.T.D. (Original Tread Depth)																								
	8/32"	9/32"	10/32"	11/32"	12/32"	13/32"	14/32"	15/32"	16/32"	17/32"	18/32"	19/32"	20/32"	21/32"	22/32"	23/32"	24/32"	25/32"	26/32"	27/32"	28/32"	29/32"	30/32"	31/32"	32/32"
2/32"	0%	0%	0%	0%	0%	0%	0%	0%	0%	0%	0%	0%	0%	0%	0%	0%	0%	0%	0%	0%	0%	0%	0%	0%	0%
3/32"	17%	14%	13%	11%	10%	9%	8%	8%	7%	7%	6%	6%	6%	5%	5%	5%	5%	4%	4%	4%	4%	4%	4%	3%	3%
4/32"	33%	29%	25%	22%	20%	18%	17%	15%	14%	13%	13%	12%	11%	11%	10%	10%	9%	9%	8%	8%	8%	7%	7%	7%	7%
5/32"	50%	43%	38%	33%	30%	27%	25%	23%	21%	20%	19%	18%	17%	16%	15%	14%	14%	13%	13%	12%	12%	11%	11%	10%	10%
6/32"	100%	57%	50%	44%	40%	36%	33%	31%	29%	27%	25%	24%	22%	21%	20%	19%	18%	17%	17%	16%	15%	15%	14%	14%	13%
7/32"	100%	100%	63%	56%	50%	45%	42%	38%	36%	33%	31%	29%	28%	26%	25%	24%	23%	22%	21%	20%	19%	19%	18%	17%	17%
8/32"	100%	100%	100%	67%	60%	55%	50%	46%	43%	40%	38%	35%	33%	32%	30%	29%	27%	26%	25%	24%	23%	22%	21%	21%	20%
9/32"		100%	100%	100%	70%	64%	58%	54%	50%	47%	44%	41%	39%	37%	35%	33%	32%	30%	29%	28%	27%	26%	25%	24%	23%
10/32"			100%	100%	100%	73%	67%	62%	57%	53%	50%	47%	44%	42%	40%	38%	36%	35%	33%	32%	31%	30%	29%	28%	27%
11/32"				100%	100%	100%	75%	69%	64%	60%	56%	53%	50%	47%	45%	43%	41%	39%	38%	36%	35%	33%	32%	31%	30%
12/32"					100%	100%	100%	77%	71%	67%	63%	59%	56%	53%	50%	48%	45%	43%	42%	40%	38%	37%	36%	34%	33%
13/32"						100%	100%	100%	79%	73%	69%	65%	61%	58%	55%	52%	50%	48%	46%	44%	42%	41%	39%	38%	37%
14/32"							100%	100%	100%	80%	75%	71%	67%	63%	60%	57%	55%	52%	50%	48%	46%	44%	43%	41%	40%
15/32"								100%	100%	100%	81%	76%	72%	68%	65%	62%	59%	57%	54%	52%	50%	48%	46%	45%	43%
16/32"									100%	100%	100%	82%	78%	74%	70%	67%	64%	61%	58%	56%	54%	52%	50%	48%	47%
17/32"										100%	100%	100%	83%	79%	75%	71%	68%	65%	63%	60%	58%	56%	54%	52%	50%
18/32"											100%	100%	100%	84%	80%	76%	73%	70%	67%	64%	62%	59%	57%	55%	53%
19/32"												100%	100%	100%	85%	81%	77%	74%	71%	68%	65%	63%	61%	59%	57%
20/32"													100%	100%	100%	86%	82%	78%	75%	72%	69%	67%	64%	62%	60%
21/32"														100%	100%	100%	86%	83%	79%	76%	73%	70%	68%	66%	63%
22/32"															100%	100%	100%	87%	83%	80%	77%	74%	71%	69%	67%
23/32"																100%	100%	100%	88%	84%	81%	78%	75%	72%	70%
24/32"																	100%	100%	100%	88%	85%	81%	79%	76%	73%
25/32"																		100%	100%	100%	88%	85%	82%	79%	77%
26/32"																			100%	100%	100%	89%	86%	83%	80%
27/32"																				100%	100%	100%	89%	86%	83%
28/32"																					100%	100%	100%	90%	87%
29/32"																						100%	100%	100%	90%
30/32"																							100%	100%	100%
31/32"																								100%	100%
32/32"																									100%

CONTACT US

For assistance, contact our customer service at 1-800-445-8646 (menu option) or your sales representative.

U.S. Headquarter Sales, Marketing & General Office

133 Peachtree Street NE, Suite 2800
Atlanta, GA 30303
1-(800) HI-KUMHO (445-8646)
KumhoTire.com

Distribution Location - Western Division

10299 6th Street
Rancho Cucamonga, CA 91730
(909) 428-3999

Distribution Location - Southeast Division

1240 Highway 155 South
McDonough, GA 30253
(678) 593-1422

Kumho Technical Center

711 Kumho Drive
Akron, OH 44333
(330) 666-4030

Rebate Information

Kumhotireusarebates@360incentives.com
1-855-899-3764

Marketing/Product/Fitment Technical Support Information

Marketing@KumhoTireUSA.com

Warranty Information

Warranty@KumhoTireUSA.com

Sales Information

Sales@KumhoTireUSA.com

Sales Information

Sales@KumhoTireUSA.com

©Kumho Tire U.S.A., Inc. 11/2020



● KUMHO TIRE

Official Tire of the NBA



KUMHO TIRE USA